

GS02 CHASSIS

INSTRUCTION MANUAL

⚠ Electronics is not included.

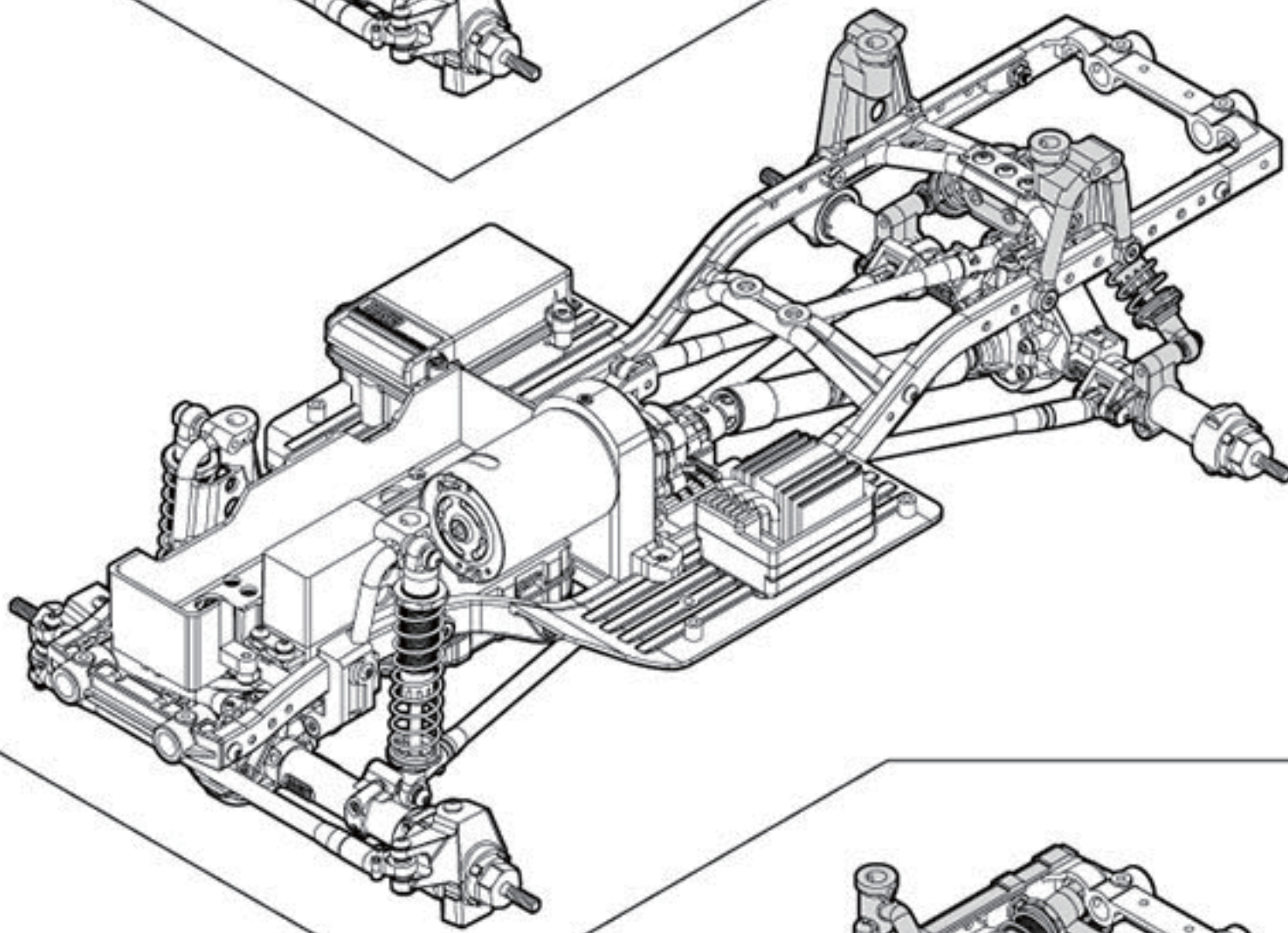
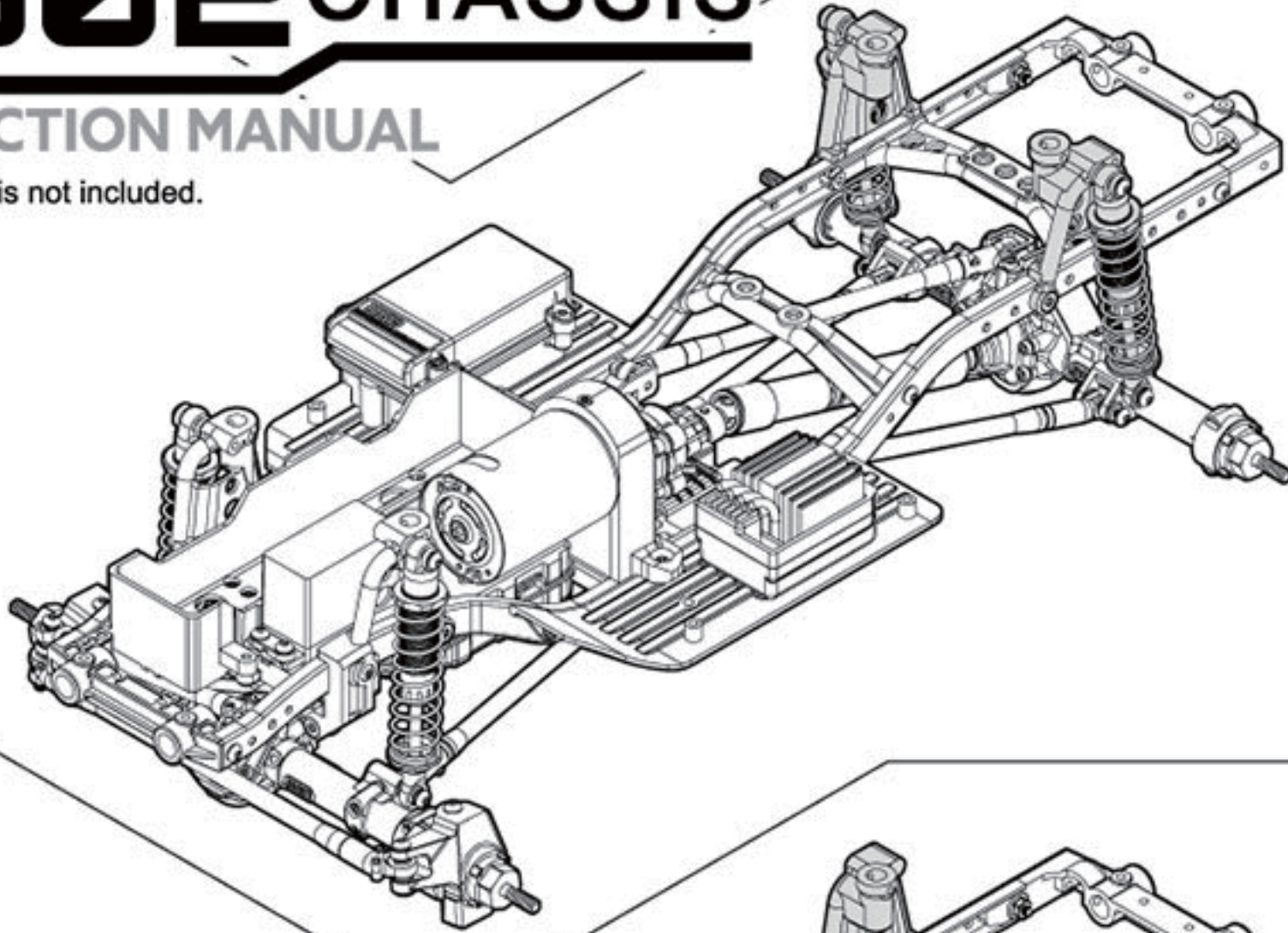

⚠ TA PRO kit only.

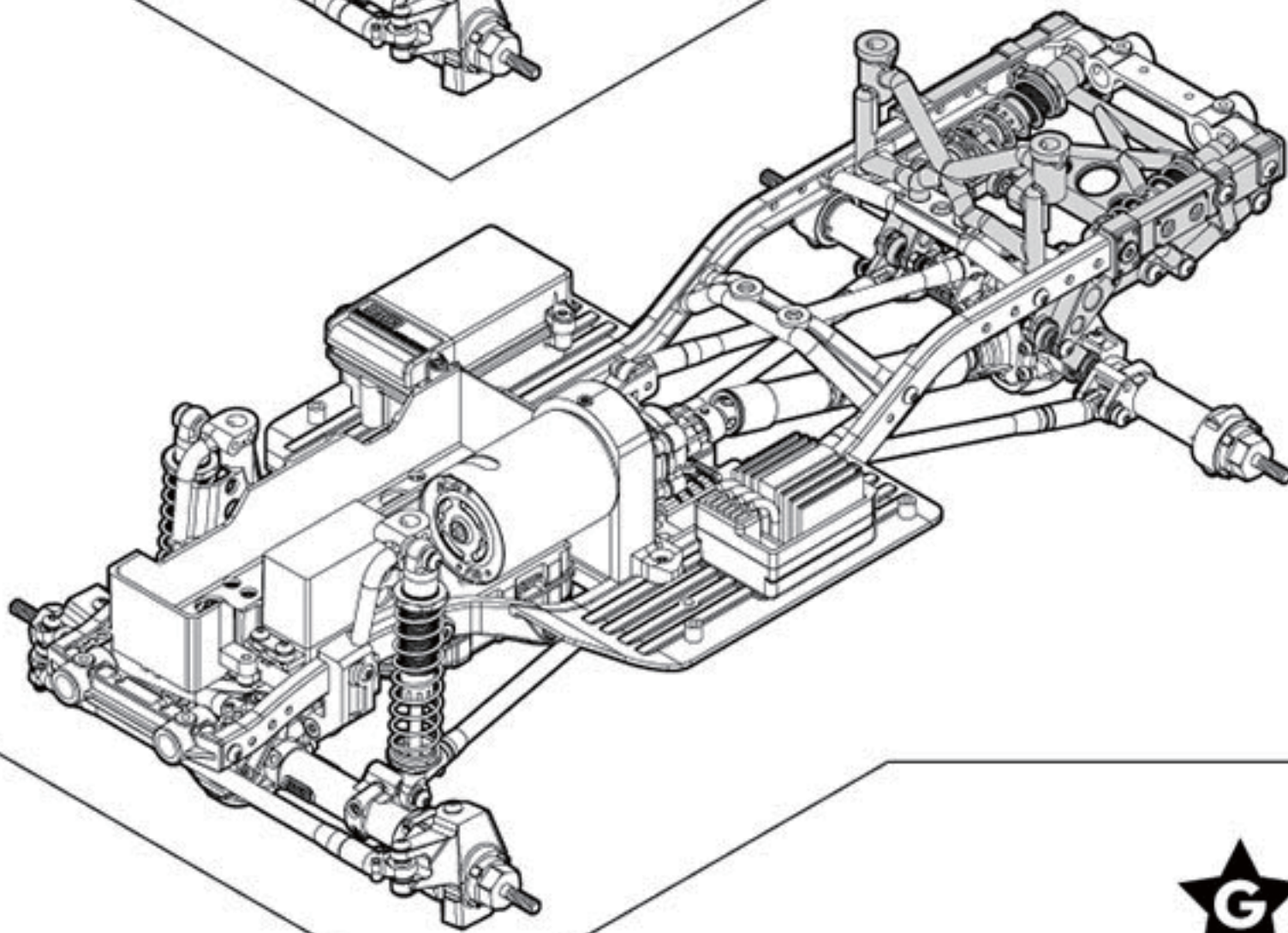

⚠ TA PRO kit only.

주의 사항



제품의 조립, 유지·보수, 안전한 작동은 사용자에게 책임이 있습니다.
반드시 해당 제품을 작동하는데 필요한 모든 안전사항을 준수하시기 바랍니다.

이 제품은 어린이용 장난감이 아닙니다. 사용 가능 연령을 꼭 확인하시기 바랍니다.

이 제품은 만 14세 이상의 사용자에게 적합한 제품입니다. 어린아이의 손에 닿지 않도록 주의하시기 바랍니다.
또한, 만 18세 미만의 사용자는 제품의 주의사항을 충분히 숙지한 성인의 지도하에 제품을 조립·작동하여 주시기 바랍니다.

1. 제품을 조립하기 전에 설명서 전체를 읽고 숙지하도록 하십시오.

- 제품을 조립하기 전에 반드시 매뉴얼 전체를 숙지한 후 제품을 조립하도록 하십시오.
- 나이프나 가위, 리머 등 날카로운 도구를 사용할 경우 부상의 위험이 있습니다. 도구의 사용에 주의하시기 바랍니다.
- 본 제품은 작고 날카로운 부품이 많습니다. 사용 부주의로 인한 상해나, 부품을 삼켜 질식하는 등, 사고의 위험이 있으므로 조립시 어린아이의 손이 닿지 않도록 주의하십시오.
- 본 제품은 전자장비 및 배터리가 포함되어 있지 않은 제품입니다. 전자장비 및 배터리등 구동에 필요한 장비는 별도로 구매하여 주시기 바랍니다.
- 전자장비 및 배터리의 경우 해당 제품의 제조사에서 지시하는 사용 방법 및 주의 사항에 따라 주시기 바랍니다.
- 본 제품에 들어있지 않은 별도의 제품이나 도구(페인트 또는 접착제, 공구등)를 사용 할 경우 해당 제품의 사용 방법 및 주의 사항에 따라 주시기 바랍니다.
- 별도로 구매한 전자장비 및 배터리, 페인트, 접착제 등의 오작동 및 사용 미숙으로 인한 문제 발생시 본 회사에서 책임지지 않습니다.

2. 작동 전 제품의 상태를 점검하여 주십시오.

- 제품 조립 후 볼트와 너트가 잘 조여있는지 확인해주십시오.
- 제품의 오작동을 피하기 위해 송신기와 수신기에는 새 배터리 또는 완전하게 충전된 배터리를 사용해 주십시오.
소모된 배터리는 송,수신 기능을 저하시키고, 심할 경우 조종불능이 되어 심각한 사고를 일으킬 수 있습니다.
- 전선이 손상된 배터리를 사용하지 마십시오.
배터리의 전선이 마모되었거나, 찌른 부분이 있을 경우, 회로에 합선을 일으킬 수 있습니다. 심각할 경우 화재를 유발할 수 있습니다.
- 규격에 맞는 알카라인 건전지 혹은 충전지를 사용하십시오.
부적합한 건전지 또는 충전지의 사용은 차의 전자장비에 손상을 줄 수 있습니다.
- 모든 모터의 작동 방향이 조작한 방향으로 작동하는지 확인해 주십시오. 만약 다르다면 방향부터 조정해주십시오.
- 본 제품에는 회전하는 부분과 날카로운 금속 부품이 많습니다. 상해를 입지 않도록 주의하십시오.
- 사용하기에 앞서 항상 작동 범위 체크를 수행하십시오. 무선 조종 시스템의 문제 또는 제품에 적합하지 않은 설정은 작동 불능을 일으킬 수 있습니다.

간단한 범위 테스트 방법

- 1 친구가 제품을 잡고 있게 하거나, 휠이 거치대나 다른 물체와 닿지 않게 고정하거나 놓아두십시오.
- 2 멀리 떨어지면서 송신기의 조작대로 서보가 움직이는지 체크하십시오.
- 3 비 정상적인 작동을 발견하면 범위 체크를 마무리 하십시오.

3. 제품을 작동시키기 위해 적합한 장소를 선정하십시오.

- 저녁이나 시야가 보이지 않는 상황에서 작동시키지 마십시오.
- 다음과 같은 장소에서 작동하지 마십시오.
 - 근처의 다른 지역에서 무선 조종 활동이 발생하고 있는 곳.
 - 일반 도로나 고속 도로
 - 고압선, 방송 통신용 안테나
 - 사람이나 동물 근처
 - 집안이나 좁고 막힌 장소
 - 병원이나, 주거 지역, 공원 등 제품 소음이 다른 이에게 방해할 수 있는 지역
- 물이 흐르거나 고인장소에서 주행 시 전자 부품이 물에 젖지 않도록 주의 하십시오.
- 제품을 레이스 트랙이나 확 트이고 안전한 공간에서 작동하시는 것을 권장합니다. 적합하지 않은 장소에서 작동 시 심각한 교통사고, 인적 상해, 대물 손실을 일으킬 수 있습니다.

4. 순서에 맞게 제품을 작동하십시오.

- 순서에 맞게 송신기의 전원을 켜고 끄도록 하십시오.
 - 시작시엔 송신기의 전원을 먼저 켜고 배터리를 연결 한 후 변속기의 전원을 켜도록 하십시오.
 - 종료시엔 변속기의 전원을 끄고 배터리를 제거 한 후 송신기의 전원을 끄도록 하십시오.
- 전선을 거꾸로 연결하거나, 배터리를 분해하지 마십시오. 제품 손상이나 누전을 일으킬 수 있습니다.
- 제품의 오작동을 피하기 위해 주행 전에 스티어링과 스로틀이 정상 작동하는지 확인해주십시오.
- 작동 후 모터, 변속기, 배터리가 뜨거울 수가 있습니다. 화상에 주의하십시오.

5. 제품의 사용 후 깨끗하게 정비하고 안전한 장소에 보관하십시오.

- 사용 후 모든 볼트, 너트 등은 풀림이 없는 정상적인 상태인지 체크해주십시오.
- 제품을 사용하지 않을 때는 배터리를 제거 해주십시오. 과 방전, 누전 등으로 배터리와 변속기에 손상을 줄 수 있습니다.
- 제품에 과도한 먼지나 이물질이 없도록 깨끗하게 유지해주십시오, 이를 통해 차체 수명을 연장시킬 수 있습니다.
- 모든 공구를 사용할 때 항상 주의하십시오, 상해를 막기 위해 세심한 주의가 요구됩니다.
- 제품을 뜨거운 곳이나 습한 곳에 보관하지 마십시오. 직사광선도 피해주세요.
- 제품의 손상을 막기 위해서 (주)지메이드코리아에서 출시하는 옵션파트나 부품 외의 것으로 개조하지 마십시오.

CAUTIONS

- ⚠** In order to avoid personal injury or property damage, you have to act in a responsible manner and follow these directions.
RC models can operate at over 40Km/h but can not stop immediately

■ Safety Precautions

- Check the surrounding area before you operate RC model.
- Choose a good place to operate your RC model
- Do not operate your RC model on the street or highway. It can cause a serious damage or a serious accident.
- Do not operate your RC model in confined or crowded areas, in order to avoid accident.
- Never operate your RC model near people or animals, and never use people or animals as an obstacle.
- A collision between your RC model and stationary objects can cause damage to either
- Do not operate your RC model in public places like hospital and residential areas. It can cause great noise
- Never operate your RC model indoor. There is a higher possibility of fire or damage

■ Safety Precautions (Before assembling)

- Before you start assembling this model, read the instructions carefully and make sure you understand them thoroughly.
- If a child assembles this model, an adult must also read the instructions carefully and understand them thoroughly.
- Always be careful when using tools like knives. Extra care should be taken to prevent injuries.
- If you use paint or cement (not included in the RC model), read the instructions supplied with them.
- Keep the parts out of reach of children, small parts can cause choking and vinyl bags can suffocate.

■ Safety Precautions (Before you operate RC model, check the following.)

- Check to ensure nuts bolts are tightened appropriately.
- Check that no one else is using your radio frequency.
- Use new batteries to avoid losing control of the transmitter and receiver.
- You will need a 2 channel radio system which includes a servo, a receiver, an ON/OFF switch, and an electronic speed control.
- Be sure to use a radio frequency for ground model – Do not use airplane frequencies.
- Always check the brakes and throttle before you operate your RC model, in order to avoid losing control of the model.
- To prevent unexpected movements of your RC model, do not connect the batteries to receiver before turning on the transmitter.
- Always turn on the transmitter first, and then connect the batteries to the receiver.
 1. Switch on the transmitter.
 2. Check that the speed control, the transmitter control, and trims are set to the neutral position.
 3. Connect the RC model to the receiver's batteries.
 4. Switch on the model and the receiver.
- When you using rechargeable batteries, make sure you read and follow the instructions carefully.
- Inappropriate handling or usage of rechargeable batteries can cause serious injuries or accidents.

■ Cautions While Operating

- When the RC model is operating, do not touch the moving parts like the drive shaft and wheels.
- The moving parts can cause serious injuries.
- Always turn the model or receiver off and disconnect the batteries before turning off the transmitter, in order to avoid unexpected movements of your RC model.
 1. Turn off the model or receiver.
 2. Disconnect the batteries.
 3. Turn off the transmitter.
- Do not touch the vehicle's speed control resistor while operating of the RC model. The resistor may be very hot, especially after running at lower speeds.
- To prevent damage to the RC model, remove the batteries from the model and transmitter when you don't intend to run the RC model for some time.
- After operating your RC model, batteries become hot, so please be careful when handling.
- In order to prolong the life of your RC model, please keep it free from dirt and grease.
- Before you start assembling this model, read the instruction carefully and make sure you understand them fully.
- If a child assembles this model, an adult must also read the instructions carefully and understand them thoroughly.

EQUIPMENT NEEDED



Radio control system
(wheel & trigger type)

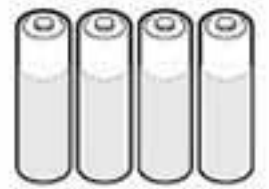

Controller
Batteries

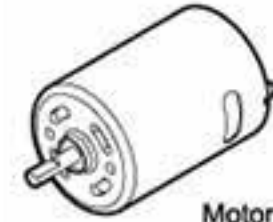

Motor

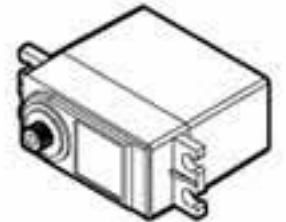

Servo

Receiver

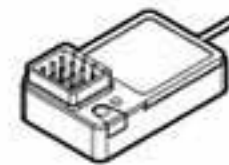

ESC

7.2V or 7.4V battery

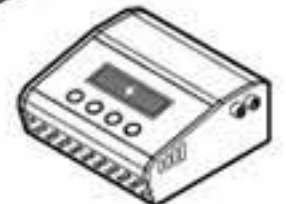
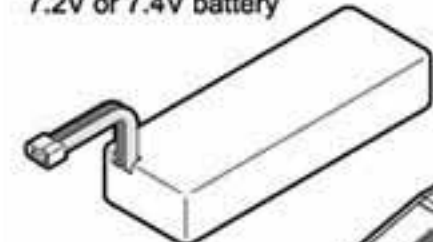

Charger

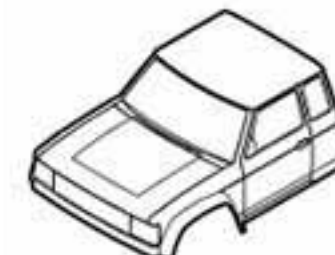

BODY

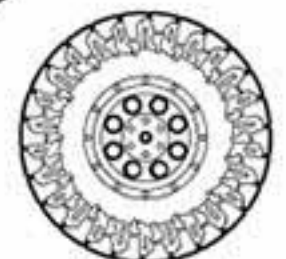

WHEELS & TIRES

TOOLS NEEDED

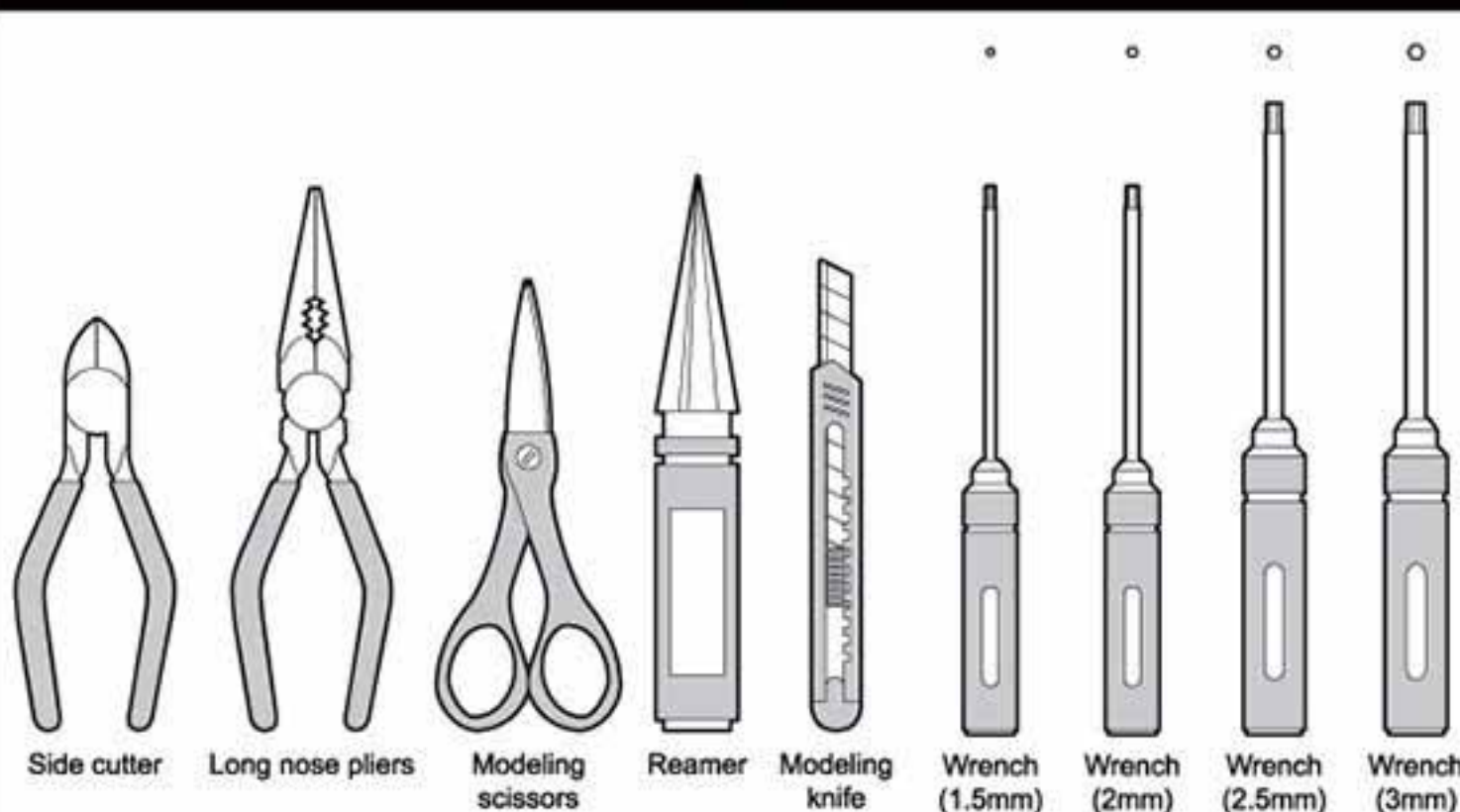

Side cutter

Long nose pliers

Modeling
scissors

Reamer

Modeling
knife

Wrench
(1.5mm)

Wrench
(2mm)

Wrench
(2.5mm)

Wrench
(3mm)

TOOLS INCLUDED

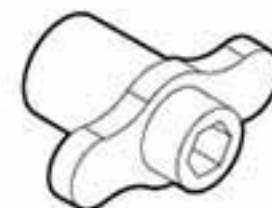

Box wrench



GM51504
Gear grease



GM20220
Shock oil

GS02 TS CHASSIS KIT PARTS REFERENCE

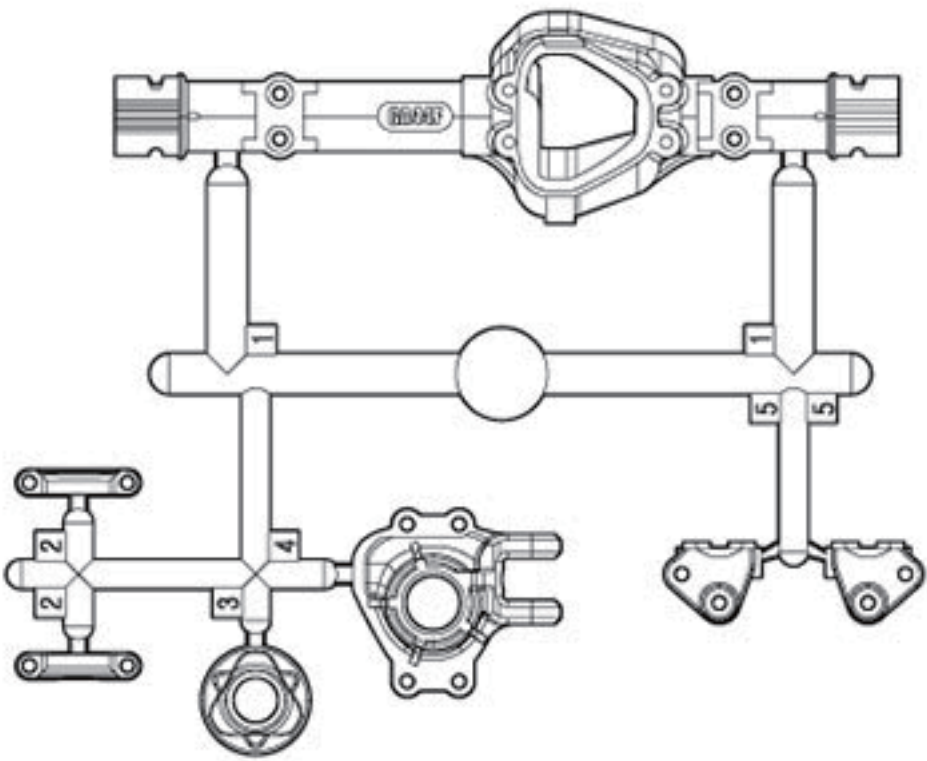

GM60061
GA44 front axle housing parts tree **x1**

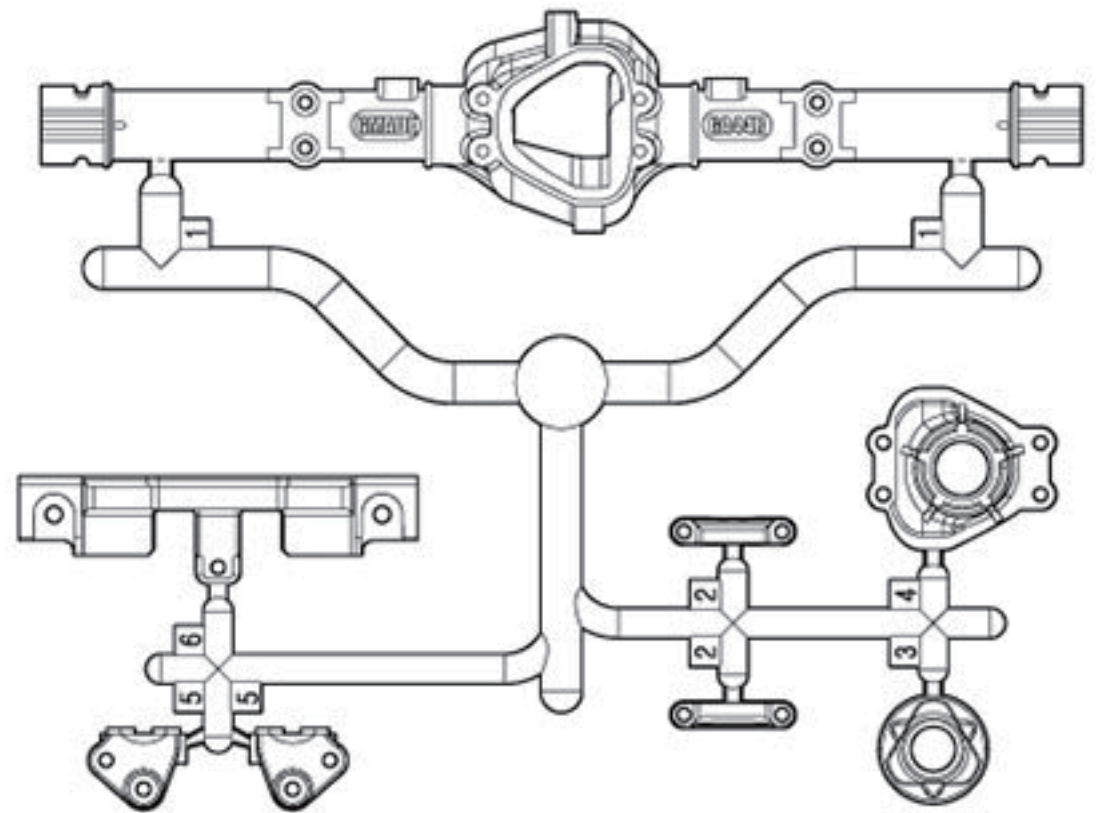

GM60062
GA44 rear axle housing parts tree **x1**

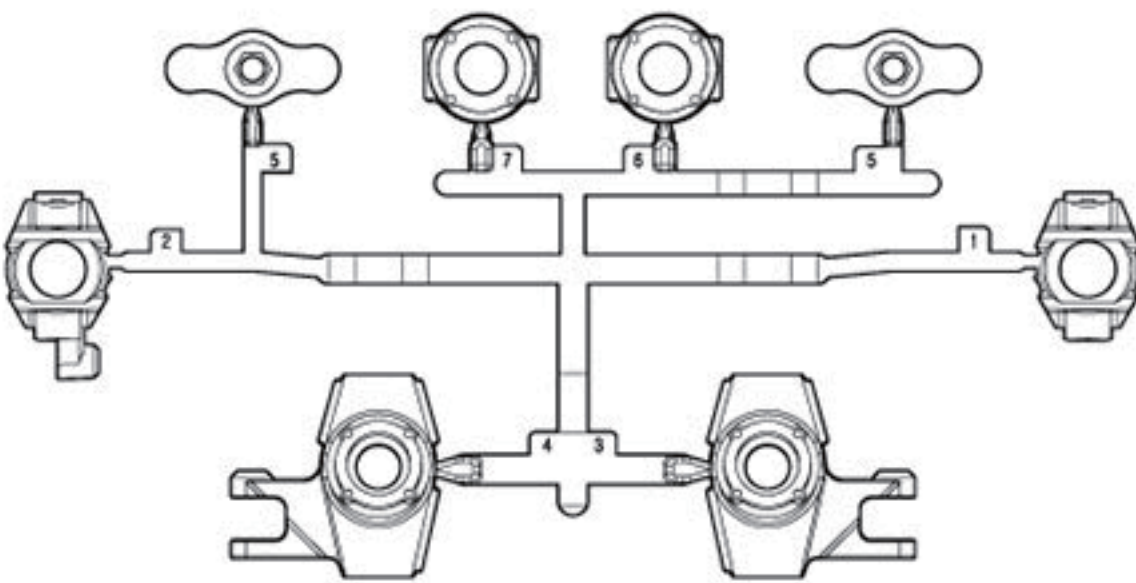

GM60063
GA44 axle parts tree **x1**

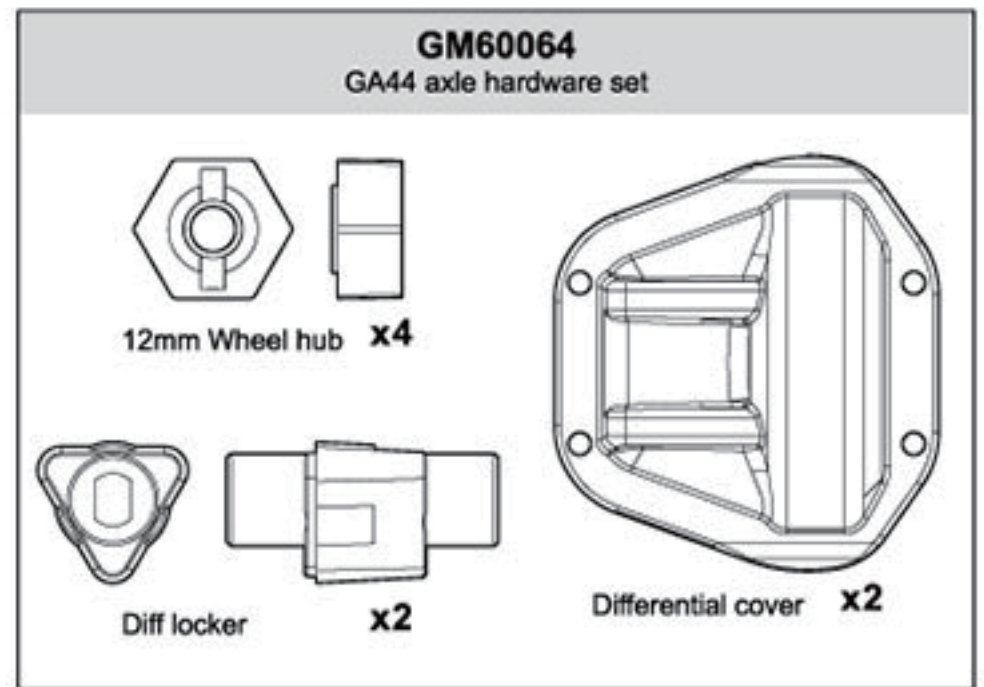

GM60064
GA44 axle hardware set

12mm Wheel hub **x4**

Diff locker

x2

Differential cover **x2**

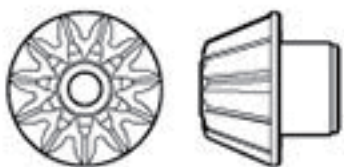

GM60067
11T Bevelgear **x2**

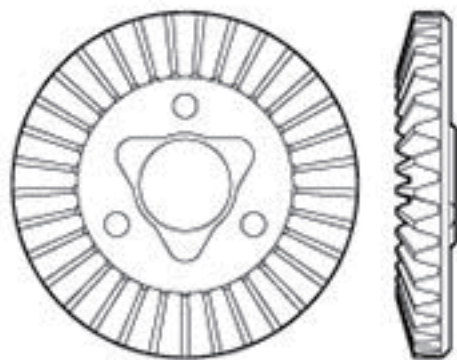

GM60068
33T Bevelgear **x2**

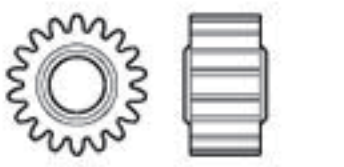

GM60069
48P 18T gear **x2**

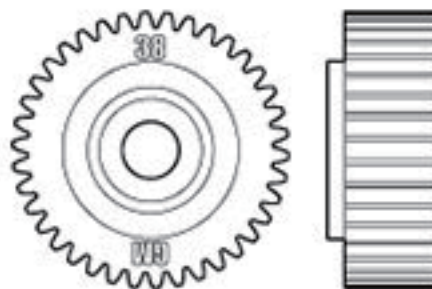

GM60071
48P 38T 1st gear (LO) **x1**

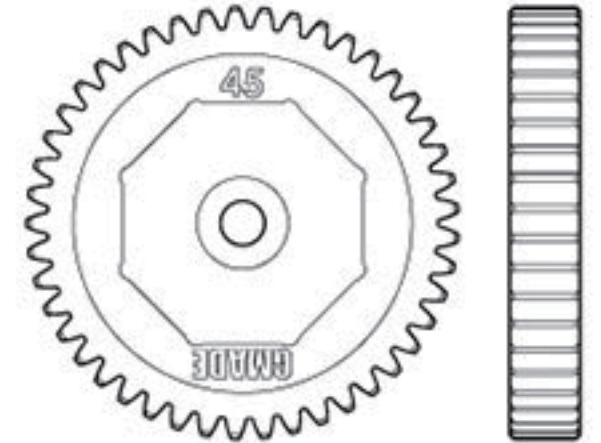

GM60080A
32P 45T Spur gear **x1**

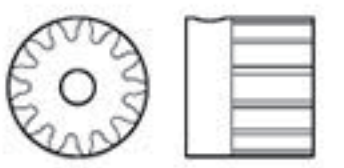

GM60072
32P 13T pinion gear **x1**

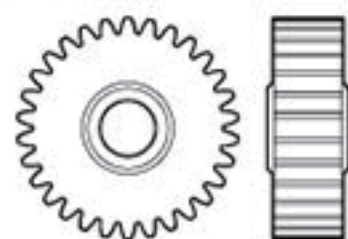

GM60070
48P 30T gear **x2**

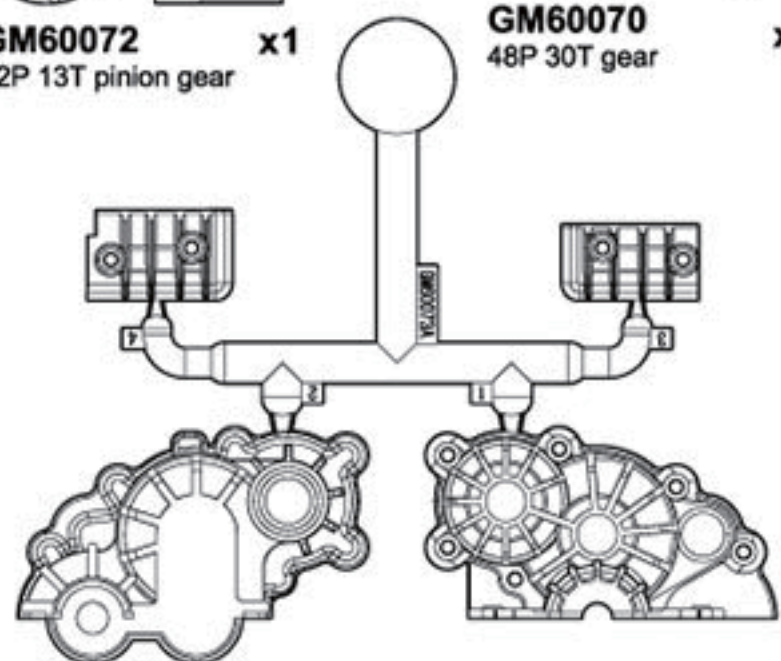

GM60073
TTR transmission housing parts tree **x1**

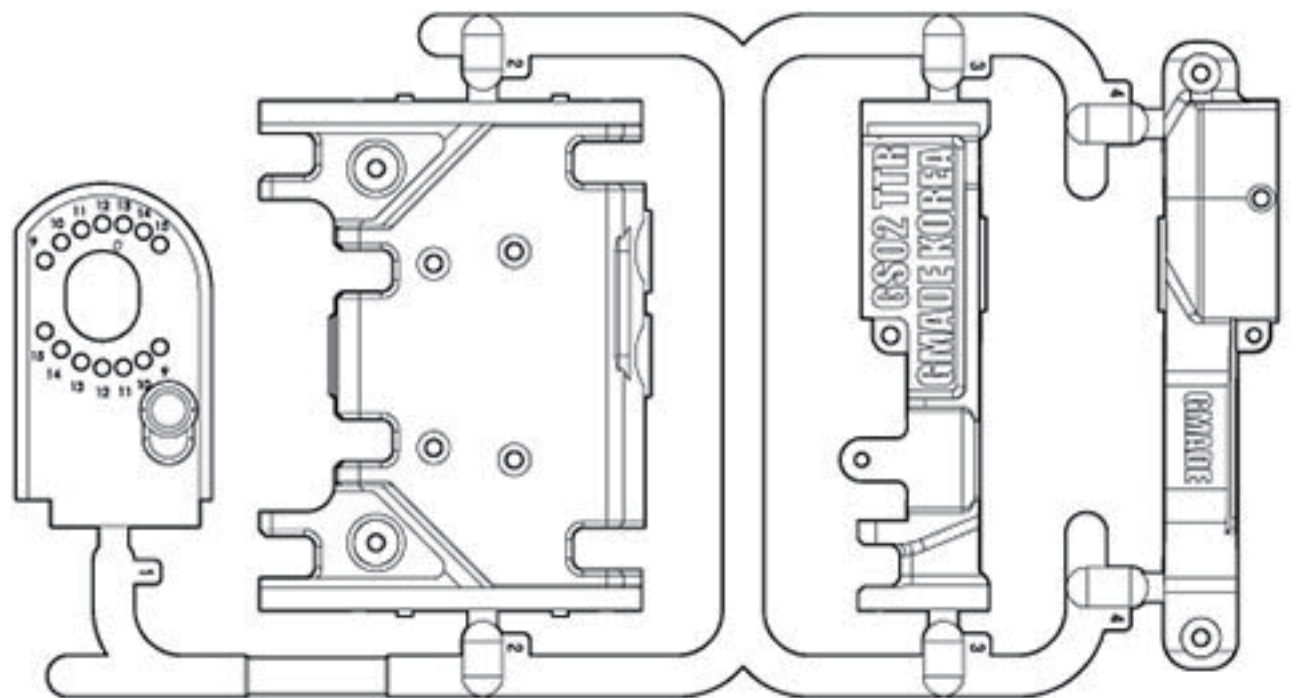

GM60074
TTR transmission motor mount parts tree **x1**

GS02 TS CHASSIS KIT PARTS REFERENCE

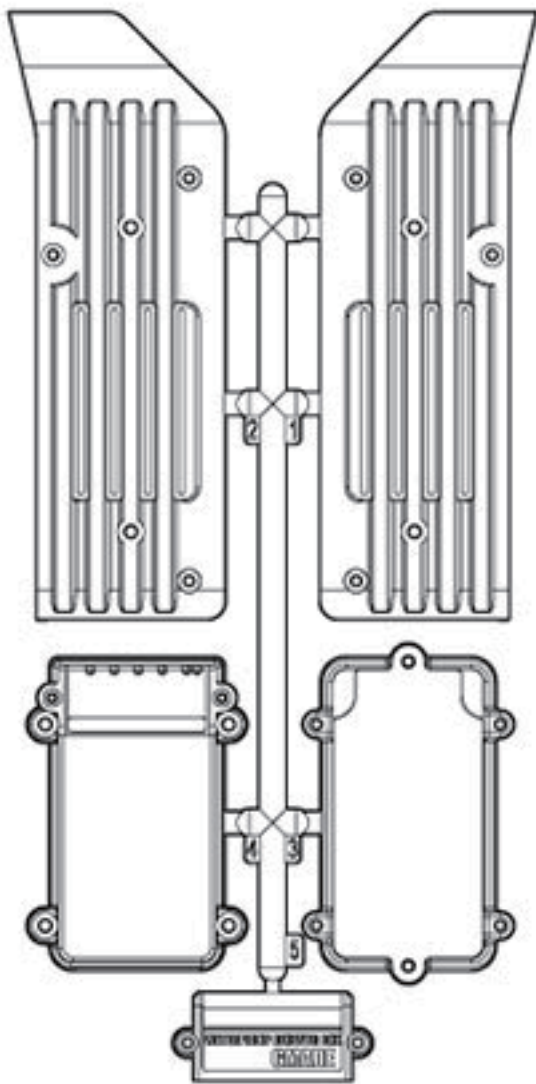

GM60076
GS02 side plate parts tree **x1**

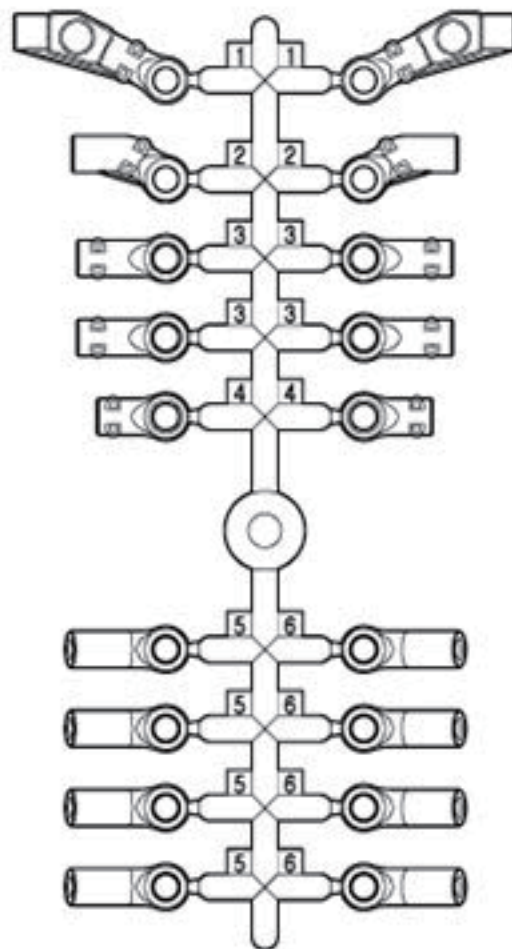

GM60022
M4 5.8mm rod end set **x2**

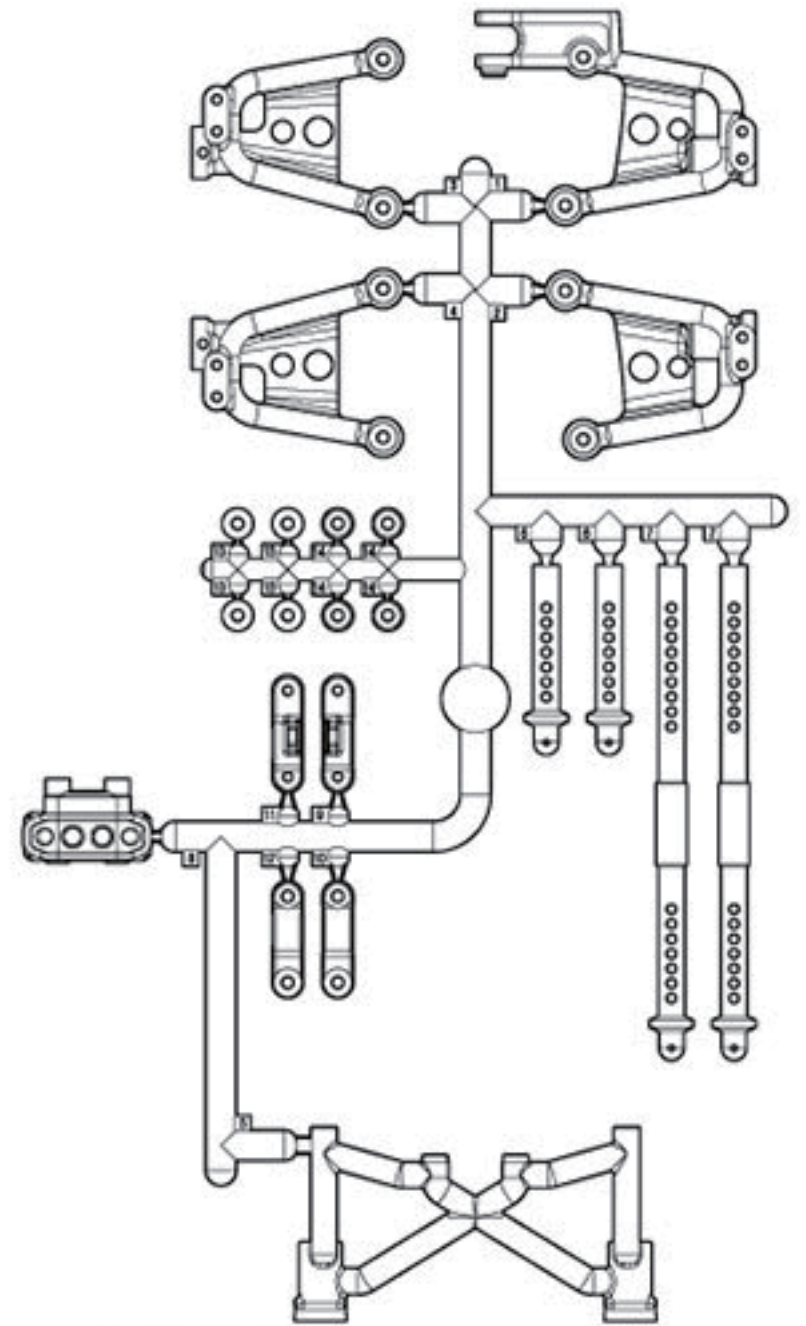

GM60077
GS02 shock hoop & body post parts tree **x1**

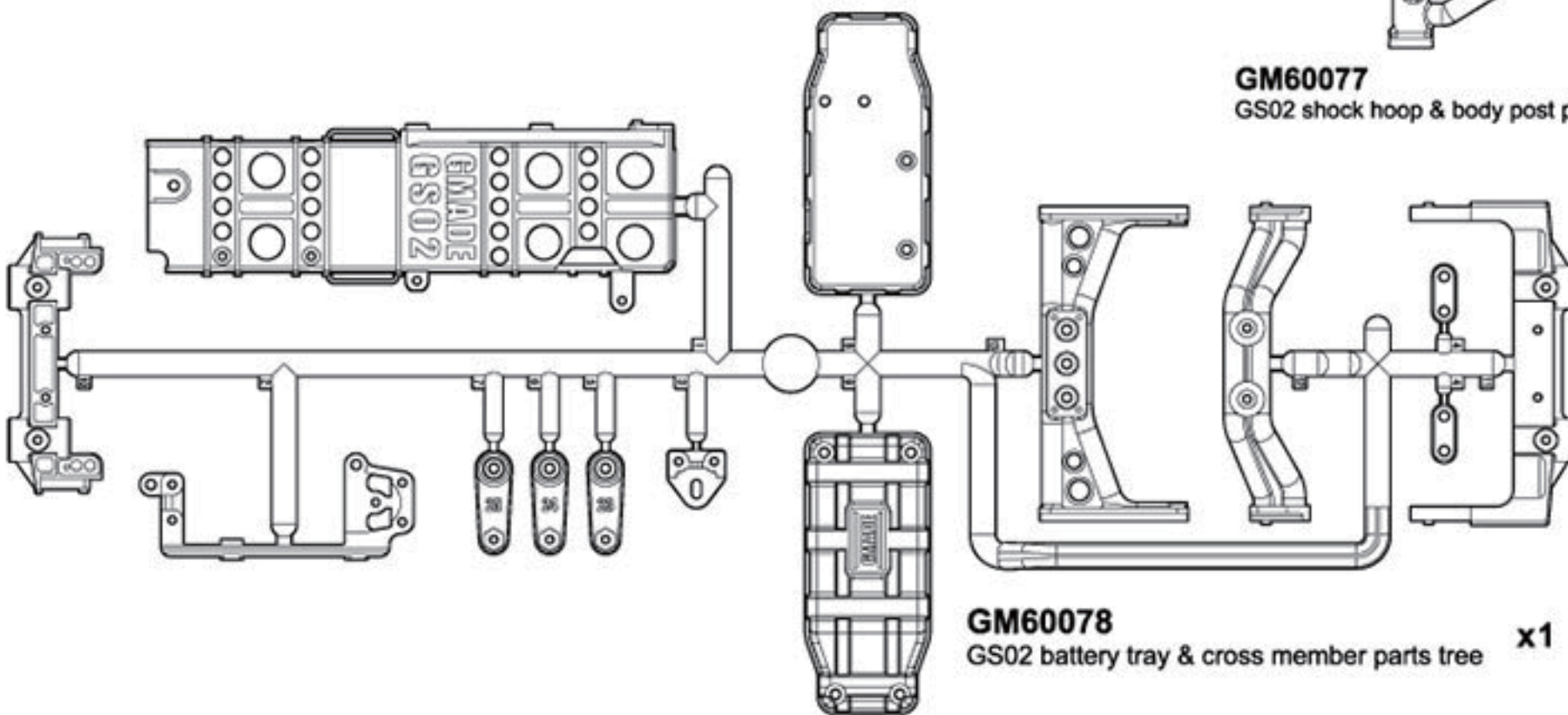

GM60078
GS02 battery tray & cross member parts tree **x1**

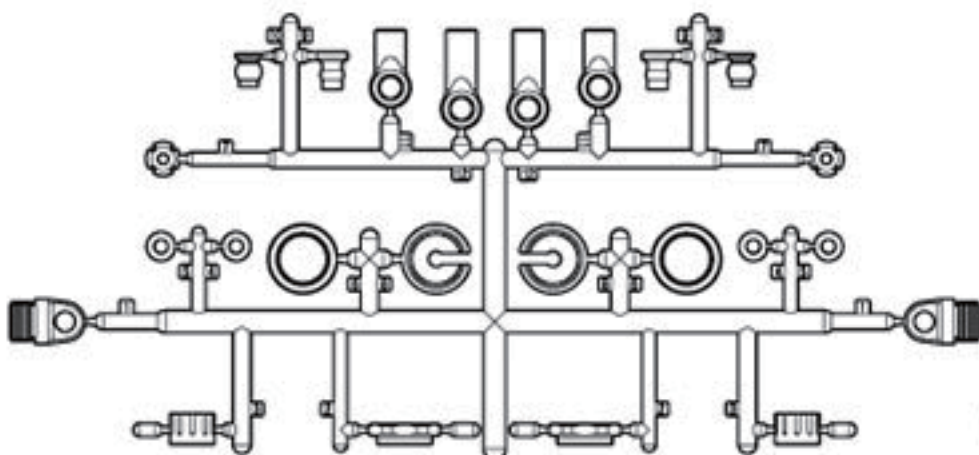

GM60079
SD shock parts tree **x2**

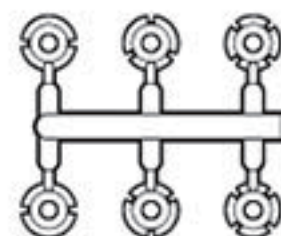

GM0020078
RSD shock delrin pistons **x2**

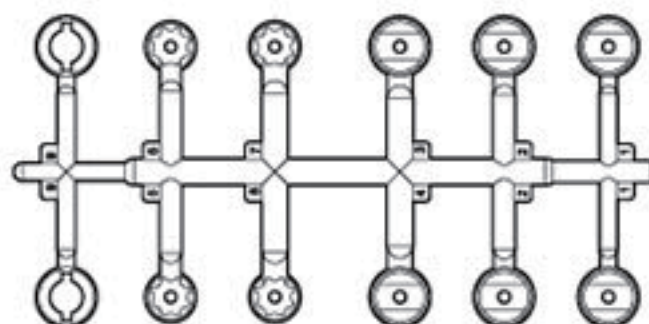

GM60084
Universal shaft parts tree **x1**

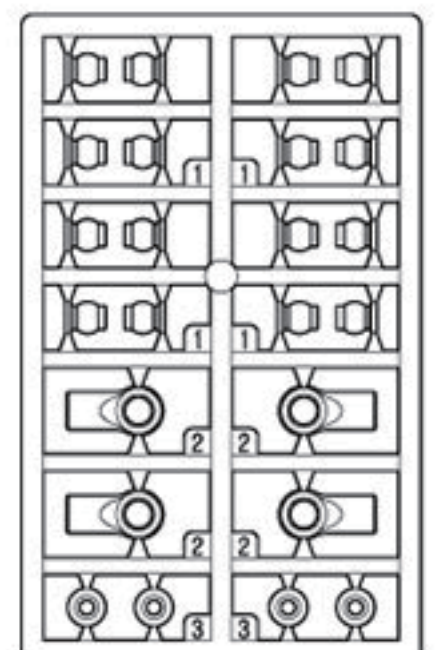

GM60023
5.8mm ball parts tree **x2**

GS02 TS CHASSIS KIT PARTS REFERENCE

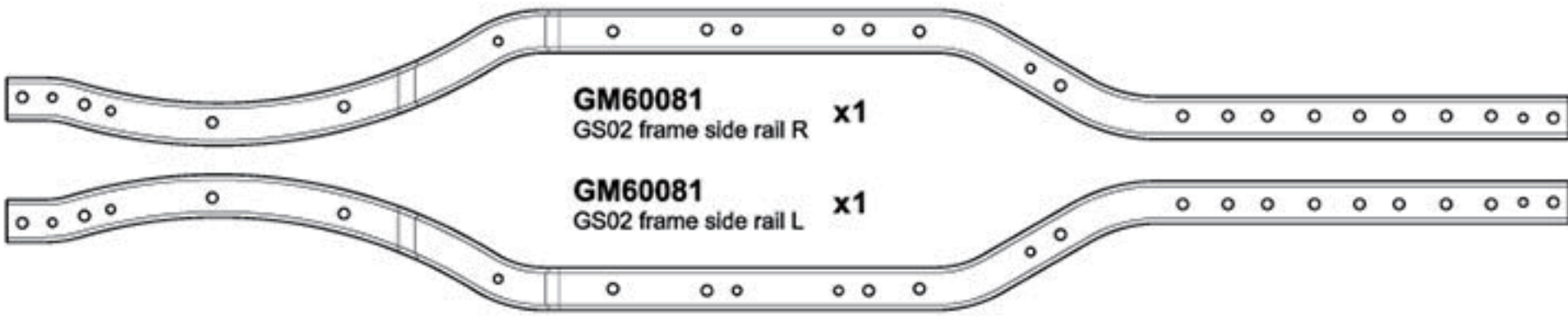

GM60081
GS02 frame side rail R **x1**

GM60081
GS02 frame side rail L **x1**



GM60109
CVA drive shaft 64mm **x1**



GM60109
CVA drive shaft 92mm **x1**



GM60112
Straight drive shaft 107mm **x2**

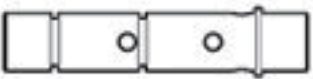

GM60113
Transmission shaft 26mm **x1**



GM60114
Slipper shaft 46mm **x1**

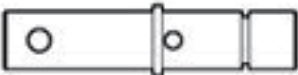

GM60115
Transmission output front shaft 25mm **x1**



GM60116
Transmission output rear shaft 63mm **x1**

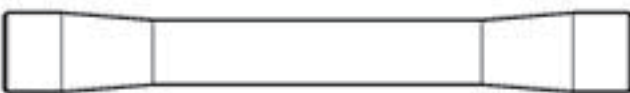

GM60089
Upper link M4x6.8x55mm **x1**



GM60090
Lower link M4x6.8x80mm **x2**



GM60091
Upper link M4x6.8x98mm **x2**



GM60092
Lower link M4x6.8x100mm **x2**

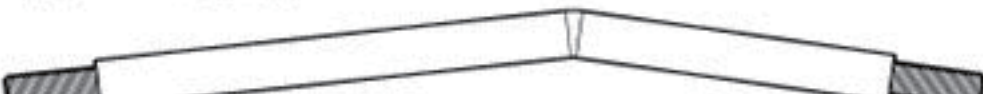

GM60099
Panhard rod 86mm **x1**



GM60100
Steering rod M4 6.8x69mm **x1**

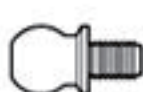

GM60093
5.8mm ball stud M3x5mm **x1**



GM60100
Steering rod M4x6.8x115mm **x1**



GM60101
Universal joint **x2**



GM60101
Universal joint cup **x4**



GM60119
Universal joint drive coupler **x4**

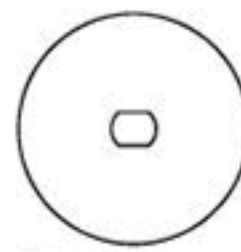

GM60087
Slipper disk 20x1.5mm **x2**

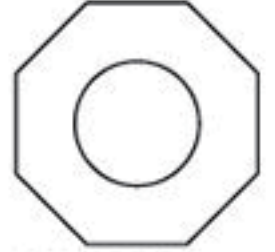

GM60088
Slipper pad **x2**



GM60097
Shock spring 15.2x61mm (Medium) **x4**



GM60094
SD 90mm shock body **x4**



GM0020075
Shock shaft 3.5x46.4mm **x4**



GM60102
CVA drive coupler **x2**

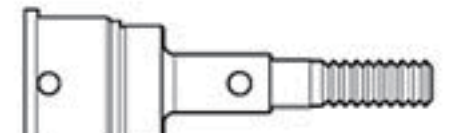

GM60109
CVA wheel axle shaft 35mm **x2**



GM60110
CVA pin retaining ring **x2**



GM60111
Input universal joint 28mm **x2**











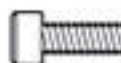

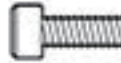



















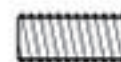

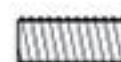







GM60117
Velcro strap 16x220mm **x1**



GM60104
Foam seal **x1**

GS02 TS CHASSIS KIT PARTS REFERENCE

 GMA0011 2.5x6mm round head wrench bolt	x8	 GMA0093 2.5x8mm Wrench bolt	x16	 GMA0210 4mm conical spring washer	x4
 GMA0017 3x6mm Round head wrench bolt	x7	 GMA0094 2.5x10mm Wrench bolt	x1	 GMA0163 Ball bearing 5x8x2.5mm	x3
 GMA0018 3x8mm Round head wrench bolt	x13	 GMA0095 2.5x12mm Wrench bolt	x8	 GMA0165 Ball bearing 5x11x4mm	x17
 GMA0019 3x10mm Round head wrench bolt	x17	 GMA0126 3x3mm Socket set screw	x5	 GMA0205 Ball bearing 8x12x3.5mm	x6
 GMA0020 3x12mm Round head wrench bolt	x9	 GMA0127 3x4mm Socket set screw	x1	 GMA0167 Ball bearing 10x15x4mm	x2
 GMA0021 3x15mm Round head wrench bolt	x11	 GMA0131 3x10mm Socket set screw	x8	 GMA0169 P3 O-ring	x8
 GMA0172 3x18mm Round head wrench bolt	x7	 GMA0132 3x12mm Socket set screw	x4	 GMA0170 P5 O-ring	x4
 GMA0023 3x25mm Round head wrench bolt	x1	 GMA0133 3x15mm Socket set screw	x4	 GMA0212 7x1 O-ring	x4
 GMA0024 3x30mm Round head wrench bolt	x1	 GMA0144 4x15mm Socket set screw	x2	 GMA0160 2mm E-ring	x6
 GMA0057 3x8mm Flat head wrench bolt	x5	 GMA0145 4x20mm Socket set screw	x16	 GMA0162 4mm E-ring	x6
 GMA0058 3x10mm Flat head wrench bolt	x7	 GM60103 3x10mm Screw pin	x2	 GM60033 Pin 1.5x7.2mm	x5
 GMA0060 3x15mm Flat head wrench bolt	x1	 GMA0154 M3 Nut	x1	 GM51603 Pin 2x10.3mm	x4
 GMA0211 3x18mm Flat head wrench bolt	x4	 GMA0157 M4 nylon lock nut	x5	 GM60065 Pin 2x11.4mm	x6
 GMA0082 2x6mm Wrench bolt	x14	 GMA0191 M3 flange nut	x2	 GM50116 R6 snap pin	x4
		 GMA0159 4mm Washer	x1	 GMA0213 S56 O-ring	x1

GS02 TA PRO CHASSIS KIT PARTS REFERENCE

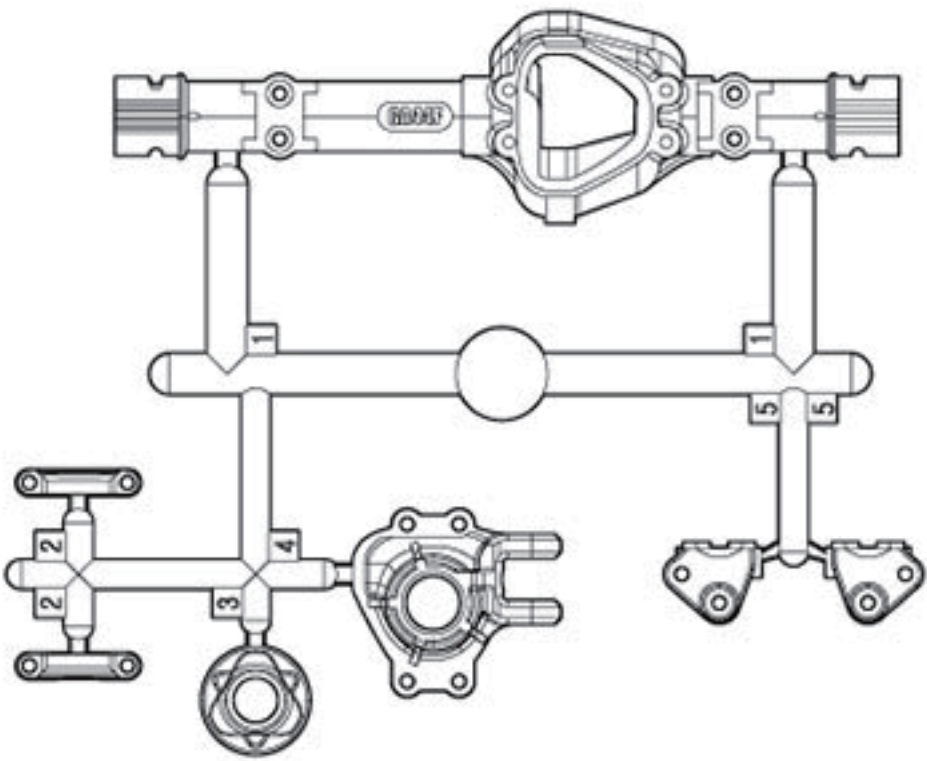

GM60061
GA44 front axle housing parts tree **x1**

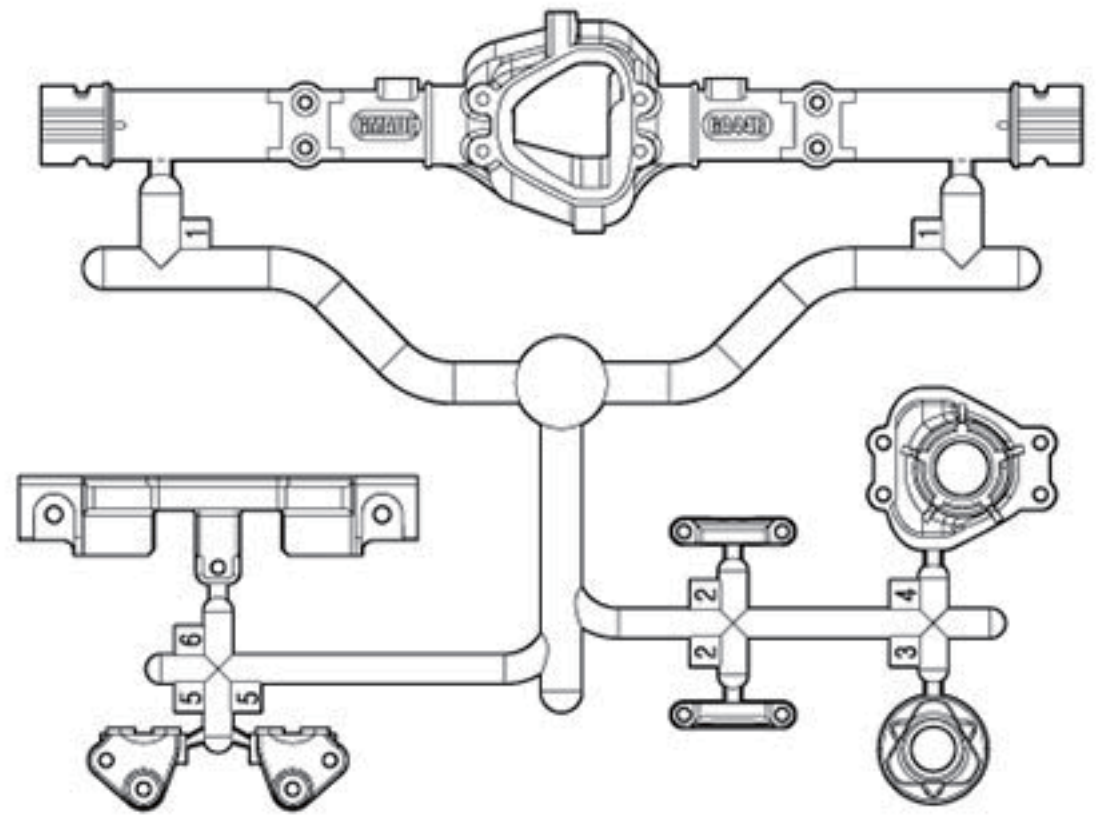

GM60062
GA44 rear axle housing parts tree **x1**

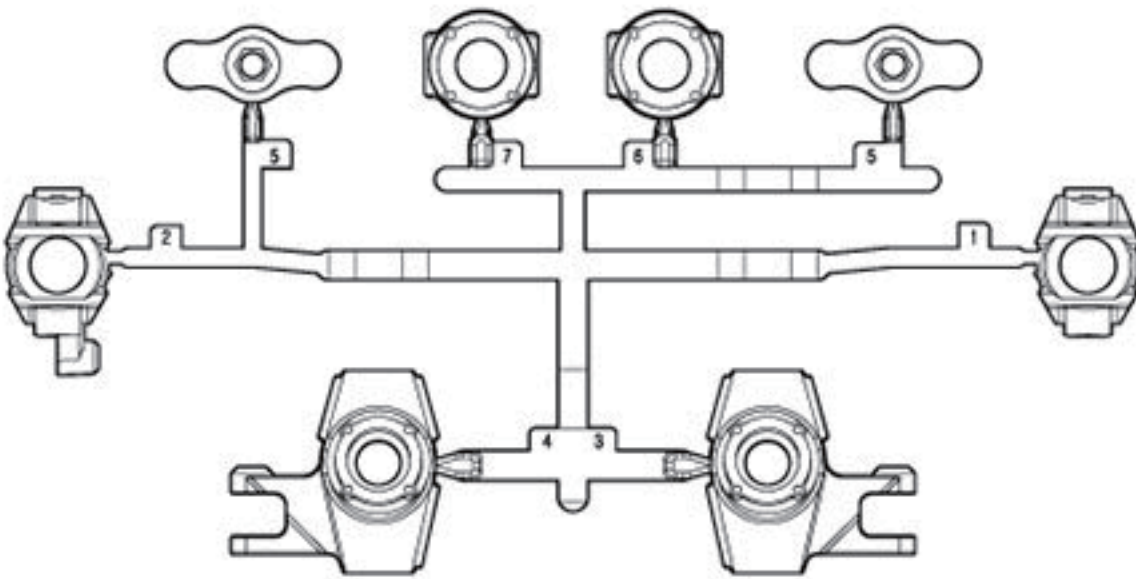

GM60063
GA44 axle parts tree **x1**



GM30131
Aluminum 12mm wheel hub
(8mm Thick) **x4**

GM30112
GA44 heavy duty diff locker **x2**

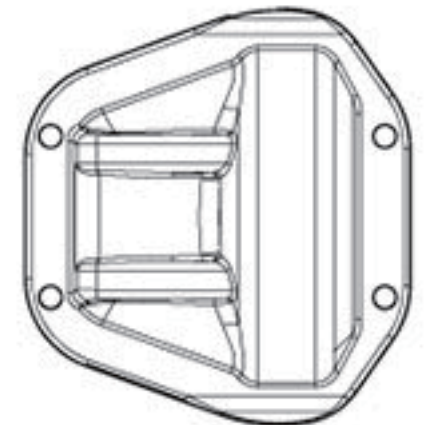

GM60064
Differential cover **x2**

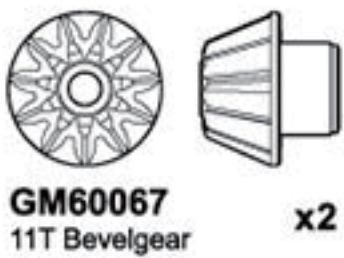

GM60067
11T Bevelgear **x2**

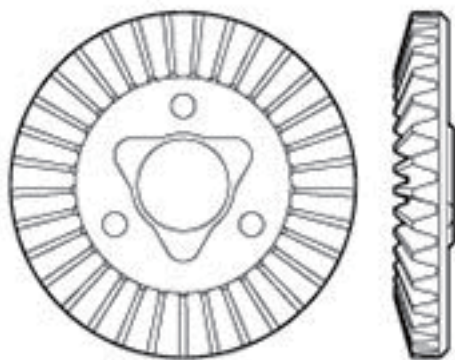

GM60068
33T Bevelgear **x2**

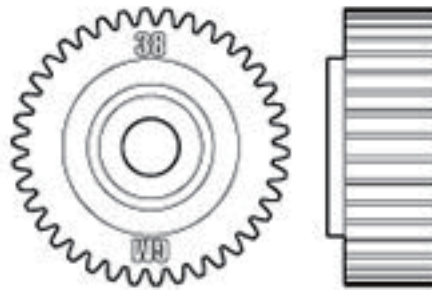

GM60071
48P 38T 1st gear (LO) **x1**

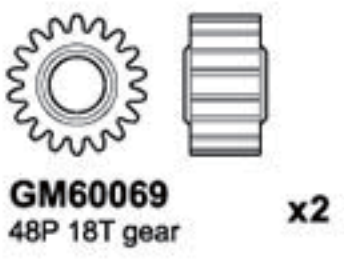

GM60069
48P 18T gear **x2**

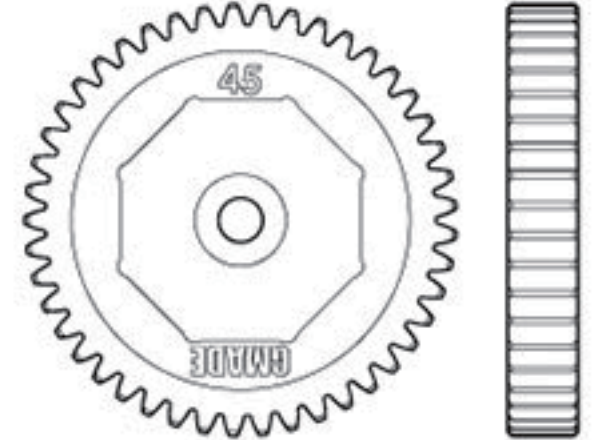

GM60080A
32P 45T Spur gear **x1**



GM60072
32P 13T pinion gear **x1**

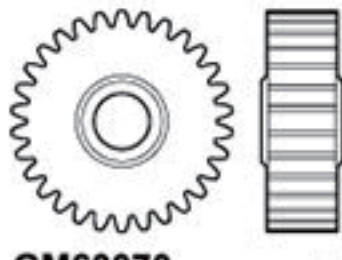

GM60070
48P 30T gear **x2**

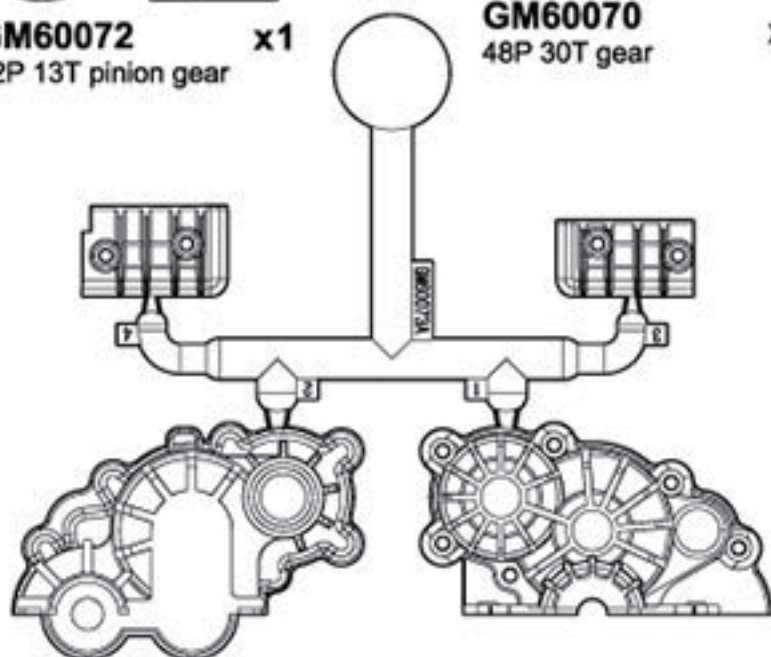

GM60073
TTR transmission housing parts tree **x1**

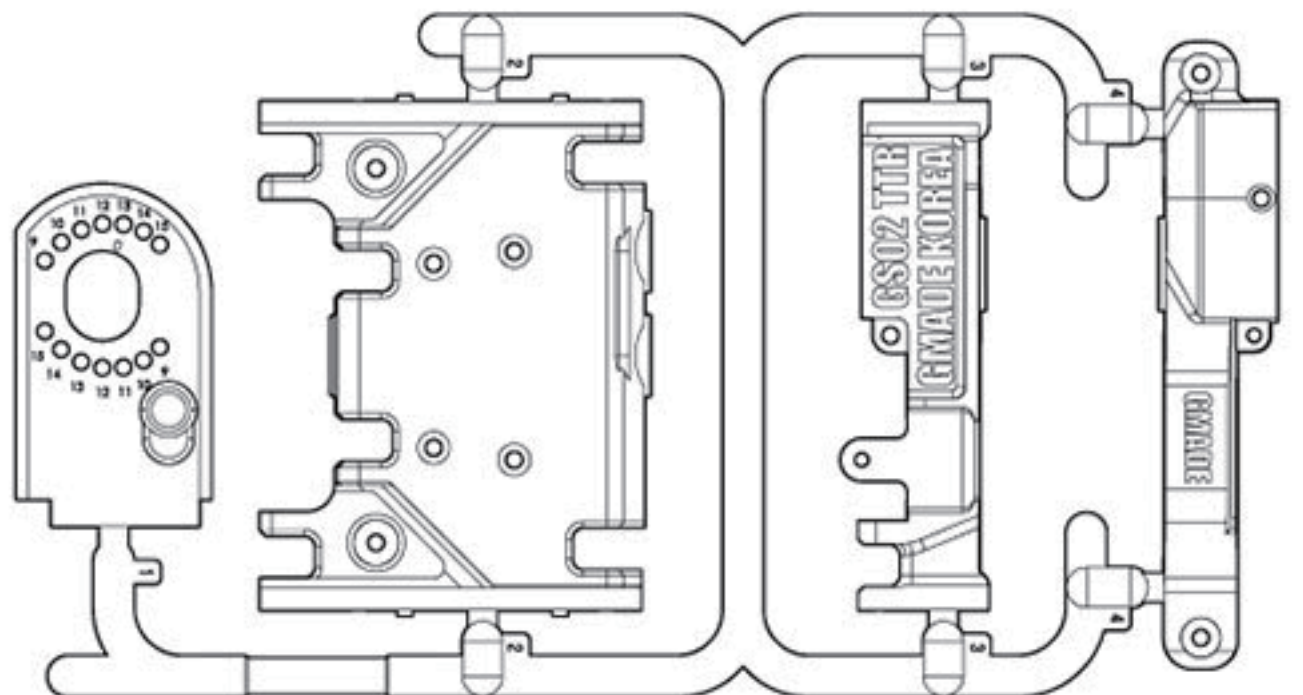

GM60074
TTR transmission motor mount parts tree **x1**

GS02 TA PRO CHASSIS KIT PARTS REFERENCE

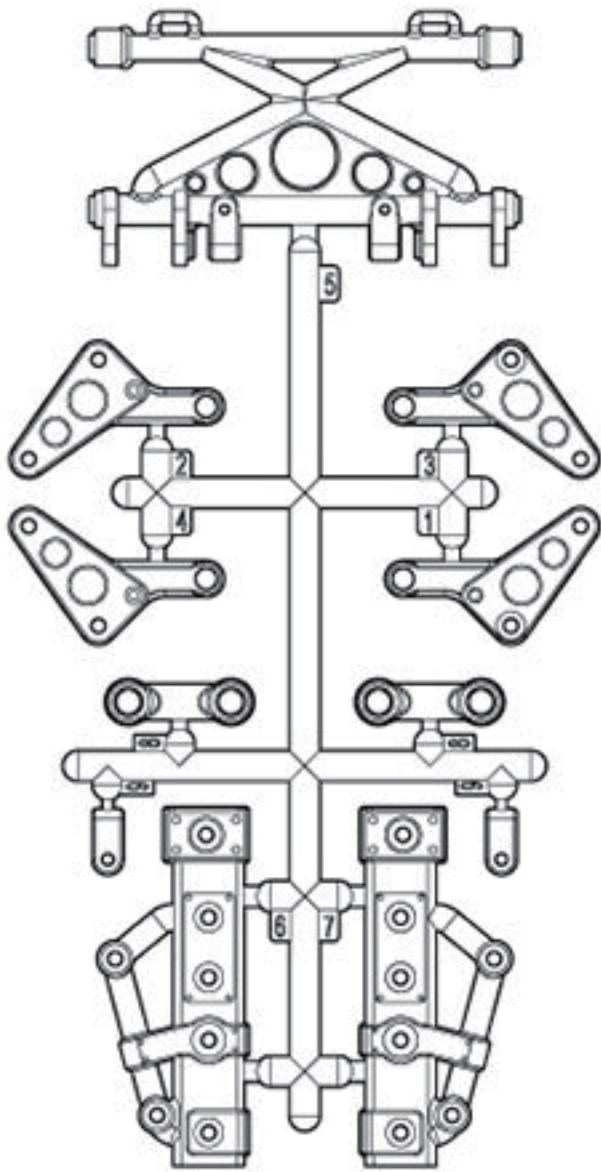

GM60075
GS02 rear cantilever suspension parts tree x1

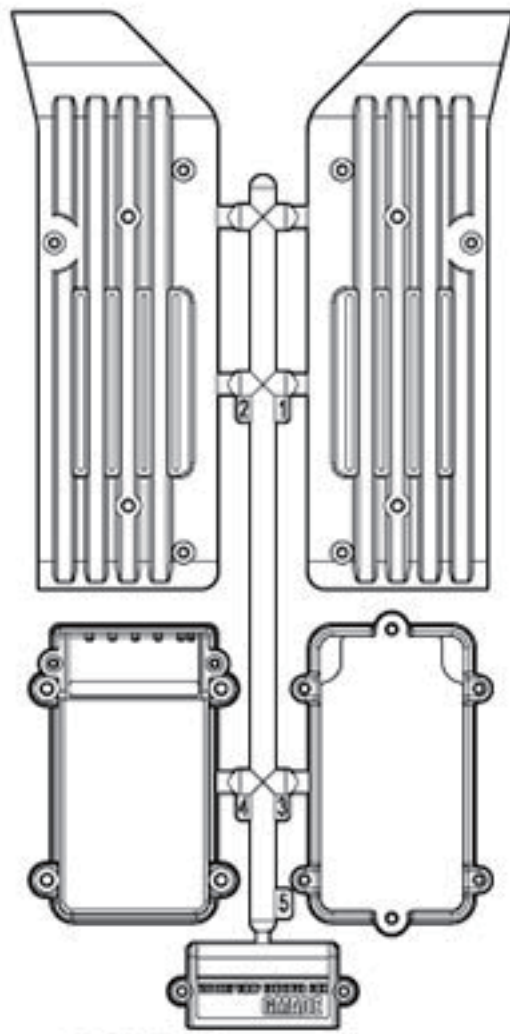

GM60076
GS02 side plate parts tree x1

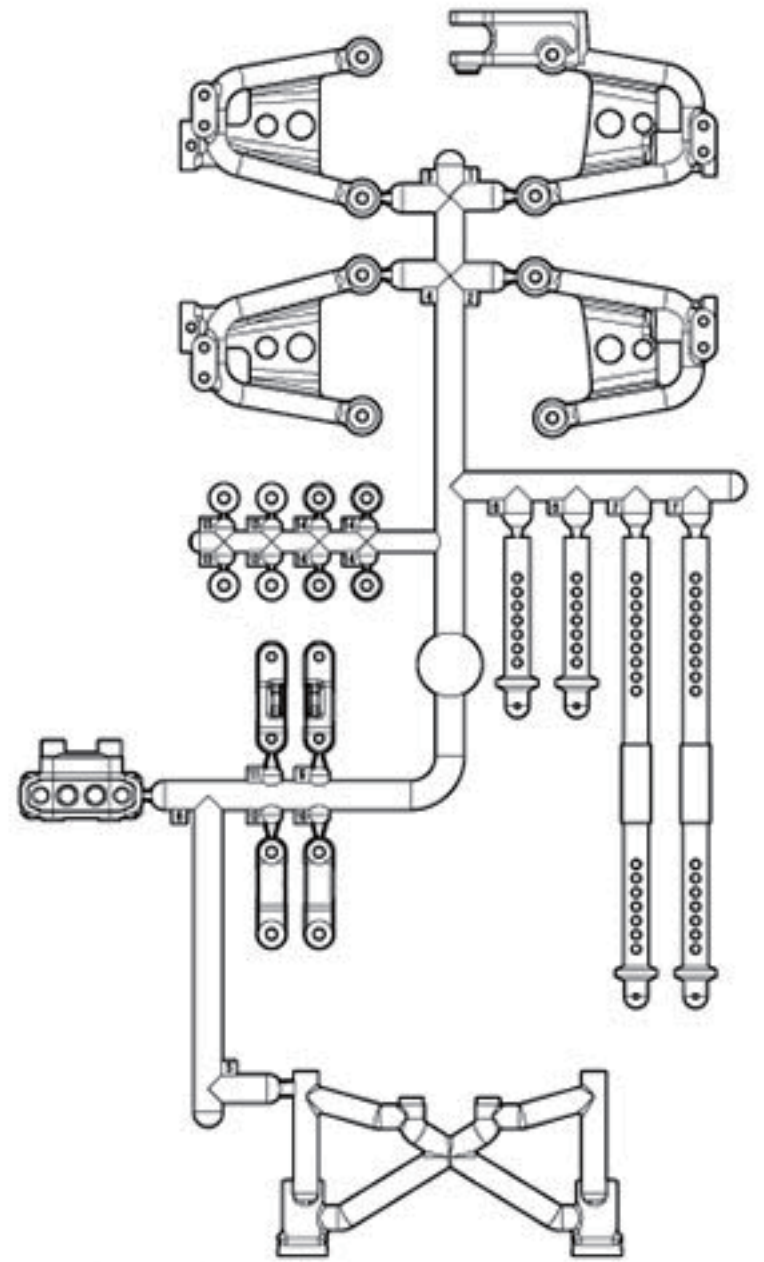

GM60077
GS02 shock hoop & body post parts tree x1

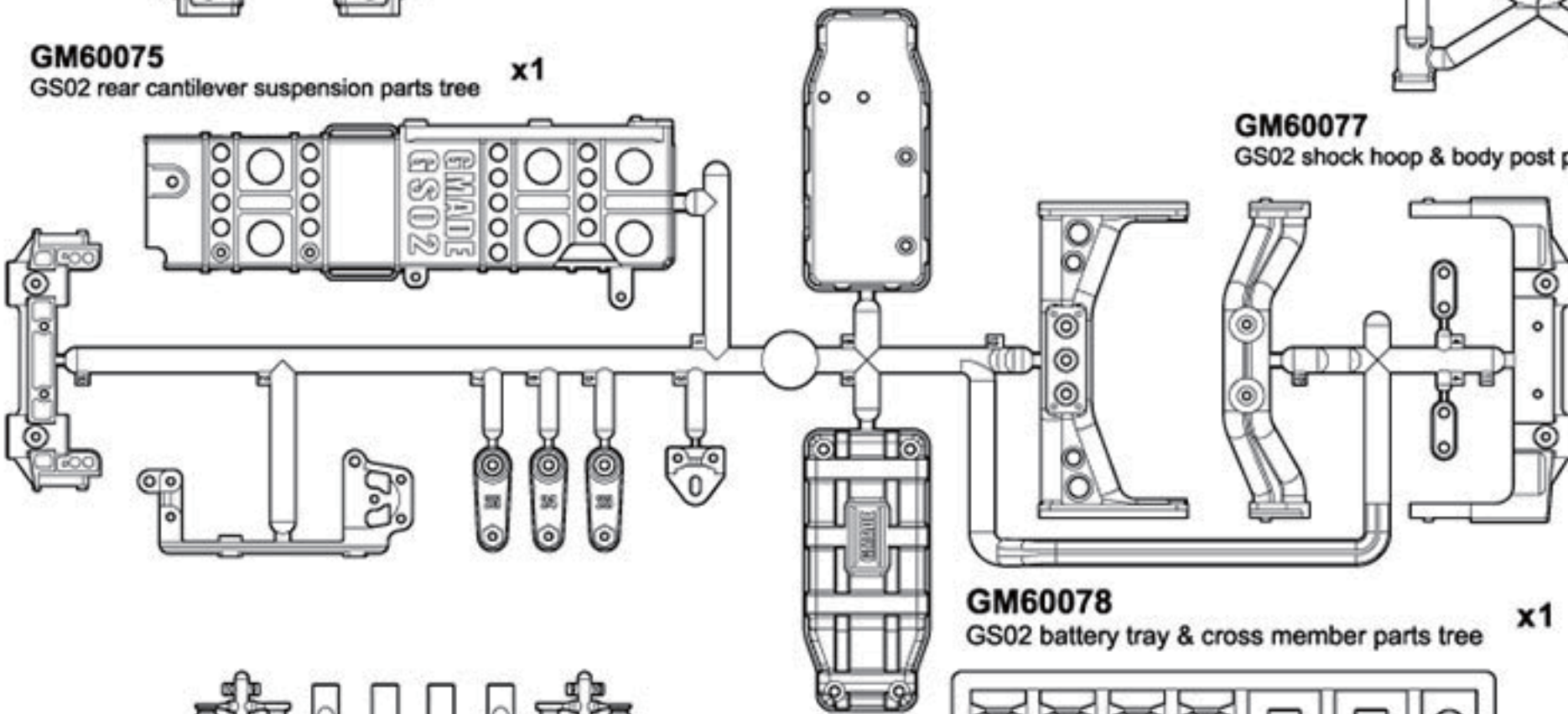

GM60078
GS02 battery tray & cross member parts tree x1

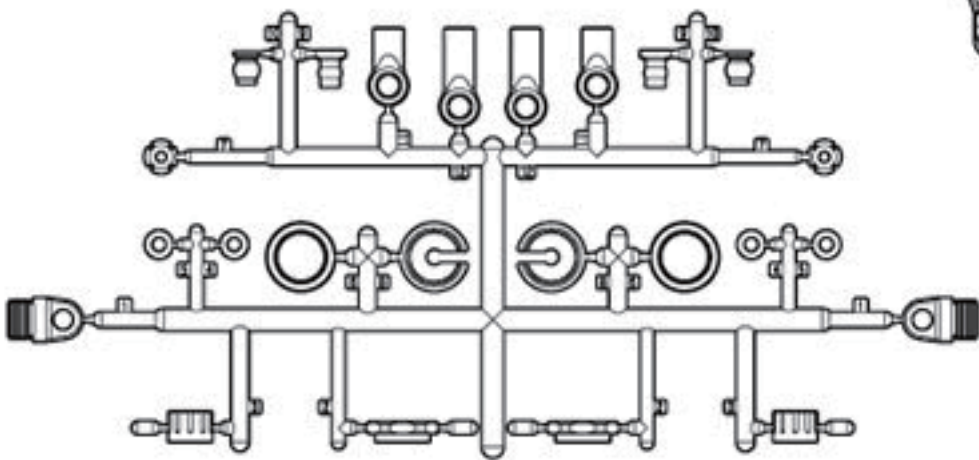

GM60079
SD shock parts tree x2

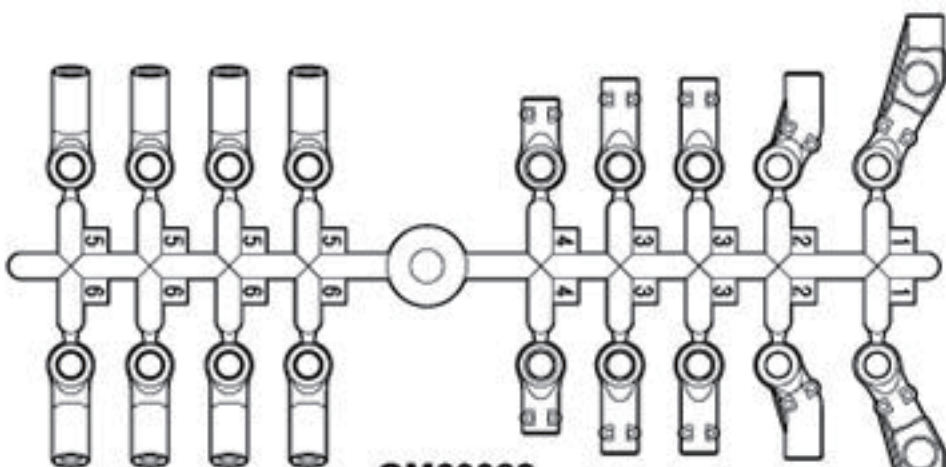

GM60022
M4 5.8mm rod end set x2

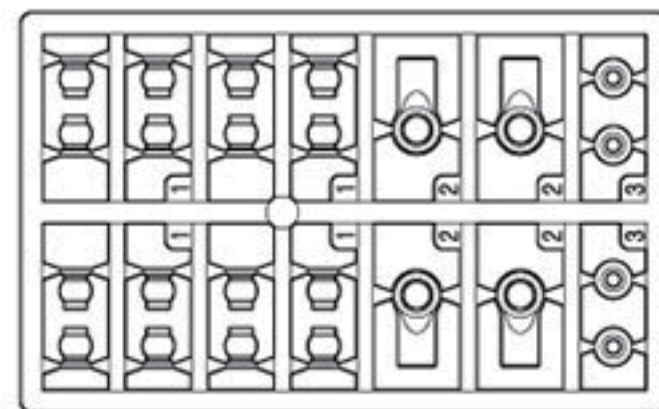

GM60023
5.8mm ball parts tree x1

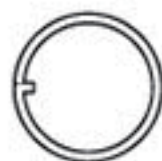

GM60123
12.8x0.7mm Pin retainer x5

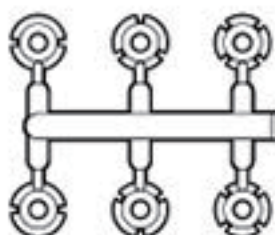

GM0020078
RSD shock delrin pistons x2



GM60119
Universal joint drive coupler x4

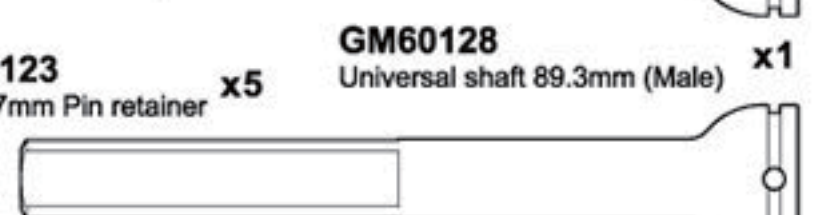

GM60128
Universal shaft 89.3mm (Male) x1

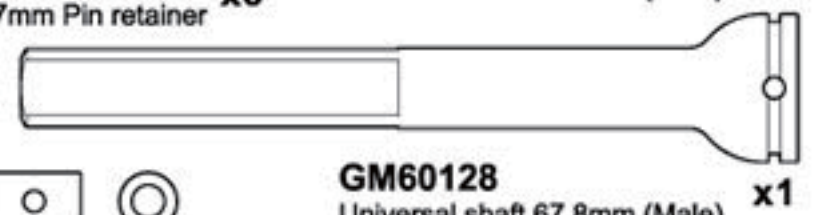

GM60128
Universal shaft 67.8mm (Male) x1



GM60128
Universal shaft 40mm (Female) x2

GS02 TA PRO CHASSIS KIT PARTS REFERENCE

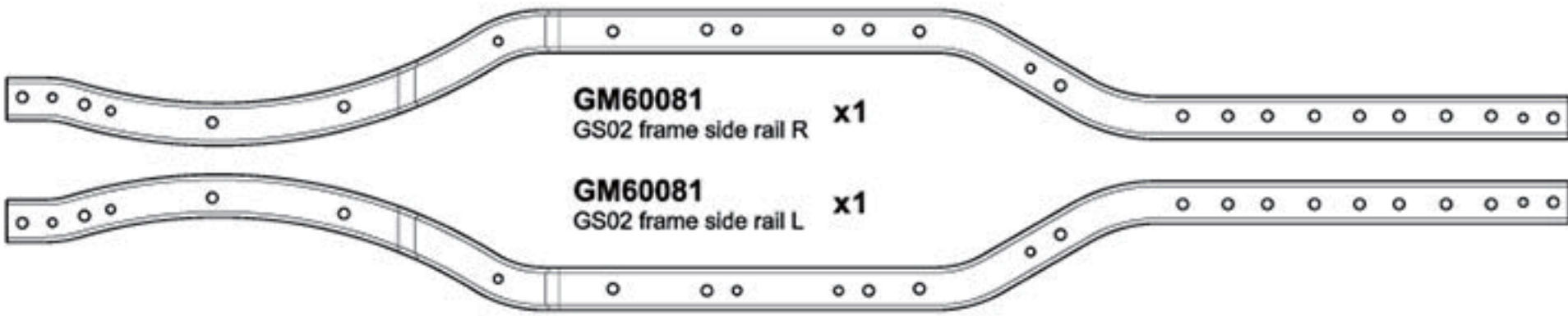

GM60081
GS02 frame side rail R **x1**

GM60081
GS02 frame side rail L **x1**



GM0020106
Shock spring 15.2x61mm (Hard) **x4**

GM60097
Shock spring 15.2x61mm (Medium) **x4**

GM0020105
Shock spring 15.2x61mm (Soft) **x4**



GM0020108
Shock spring 16.2x36mm (Hard) **x2**

GM60098
Shock spring 16.2x36mm (Medium) **x2**

GM0020107
Shock spring 16.2x36mm (Soft) **x2**



GM30144
Aluminum shock end ball 5.8x7.3mm **x27**



GM30144
Aluminum Shock Upper Ball 5x8.5mm **x4**



GM30076
GA60 Brass steering knuckle bushing **x4**



GM60110
CVA pin retaining ring **x2**



GM60109
CVA wheel axle shaft 35mm **x2**



GM60102
CVA drive coupler **x2**



GM60094
SD 90mm shock body **x4**



GM60095
SD 67mm shock body **x2**



GM60109
CVA drive shaft 64mm **x1**



GM60093
5.8mm ball stud M3x5mm **x1**



GM0020075
Shock shaft 3.5x46.4mm **x4**



GM60096
Shock shaft 3.5x33.9mm **x2**

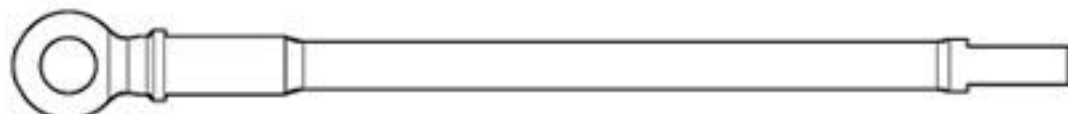

GM60109
CVA drive shaft 92mm **x1**



GM60111
Input universal joint 28mm **x2**

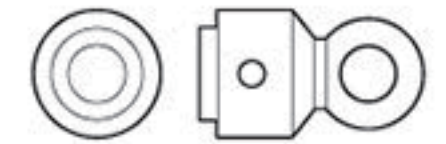

GM60101
Universal joint **x2**



GM60112
Straight drive shaft 107mm **x2**

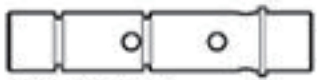

GM60113
Transmission shaft 26mm **x1**



GM60114
Slipper shaft 46mm **x1**

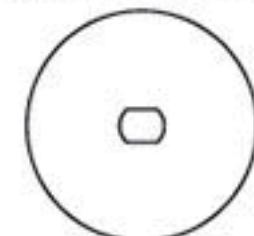

GM60087
Slipper disk 20x1.5mm **x2**



GM60088
Slipper pad **x2**

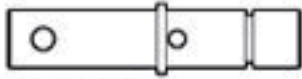

GM60115
Transmission output front shaft 25mm **x1**



GM60116
Transmission output rear shaft 63mm **x1**



GM60099
Panhard rod 86mm **x1**

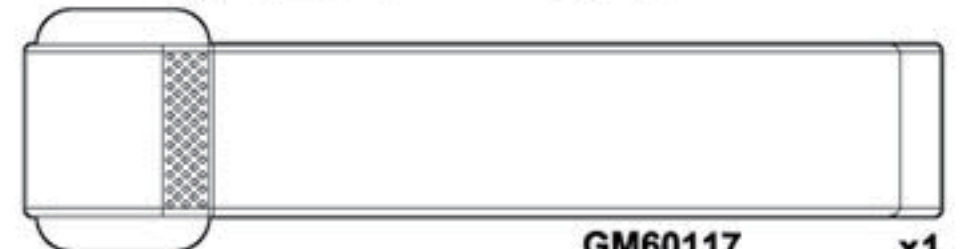

GM60117
Velcro strap 16x220mm **x1**



GM60091
Upper link M4x6.8x98mm **x2**



GM60089
Upper link M4x6.8x55mm **x1**



GM60092
Lower link M4x6.8x100mm **x2**



GM60090
Lower link M4x6.8x80mm **x2**



GM60100
Steering rod M4 6.8x69mm **x1**











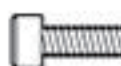

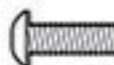

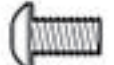

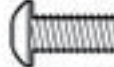

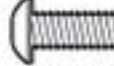

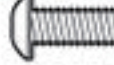

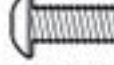



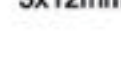

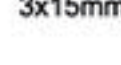

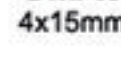
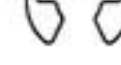

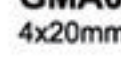

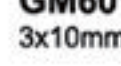



GM60100
Steering rod M4x6.8x115mm **x1**

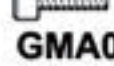

GM60104
Foam seal **x1**

GS02 TA PRO CHASSIS KIT PARTS REFERENCE

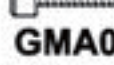
 GMA0011 2.5x6mm round head wrench bolt	x8	 GMA0093 2.5x8mm Wrench bolt	x16	 GMA0210 4mm conical spring washer	x4
 GMA0012 2.5x8mm Round head wrench bolt	x2	 GMA0094 2.5x10mm Wrench bolt	x1	 GMA0163 Ball bearing 5x8x2.5mm	x3
 GMA0017 3x6mm Round head wrench bolt	x9	 GMA0095 2.5x12mm Wrench bolt	x8	 GMA0165 Ball bearing 5x11x4mm	x17
 GMA0018 3x8mm Round head wrench bolt	x22	 GMA0126 3x3mm Socket set screw	x9	 GMA0205 Ball bearing 8x12x3.5mm	x6
 GMA0019 3x10mm Round head wrench bolt	x19	 GMA0127 3x4mm Socket set screw	x1	 GMA0167 Ball bearing 10x15x4mm	x2
 GMA0020 3x12mm Round head wrench bolt	x9	 GMA0131 3x10mm Socket set screw	x8	 GMA0169 P3 O-ring	x8
 GMA0021 3x15mm Round head wrench bolt	x11	 GMA0132 3x12mm Socket set screw	x4	 GMA0170 P5 O-ring	x4
 GMA0172 3x18mm Round head wrench bolt	x9	 GMA0133 3x15mm Socket set screw	x4	 GMA0212 7x1 O-ring	x4
 GMA0022 3x20mm Round head wrench bolt	x2	 GMA0144 4x15mm Socket set screw	x2	 GMA0160 2mm E-ring	x6
 GMA0023 3x25mm Round head wrench bolt	x1	 GMA0145 4x20mm Socket set screw	x16	 GM60033 Pin 1.5x7.2mm	x5
 GMA0024 3x30mm Round head wrench bolt	x1	 GM60103 3x10mm Screw pin	x2	 GM51603 Pin 2x10.3mm	x4
 GMA0057 3x8mm Flat head wrench bolt	x3	 GMA0154 M3 Nut	x1	 GM60065 Pin 2x11.4mm	x6
 GMA0058 3x10mm Flat head wrench bolt	x7	 GMA0156 M3 Nylon lock nut	x4	 GM50116 R6 snap pin	x4
 GMA0060 3x15mm Flat head wrench bolt	x1	 GMA0157 M4 nylon lock nut	x5	 GMA0213 x1 S56 O-ring	
 GMA0211 3x18mm Flat head wrench bolt	x6	 GMA0191 M3 flange nut	x2		
 GMA0082 2x6mm Wrench bolt	x8	 GMA0159 4mm Washer	x1		
 GMA0083 2x8mm Wrench bolt	x6				

REAR SHOCK HOOP

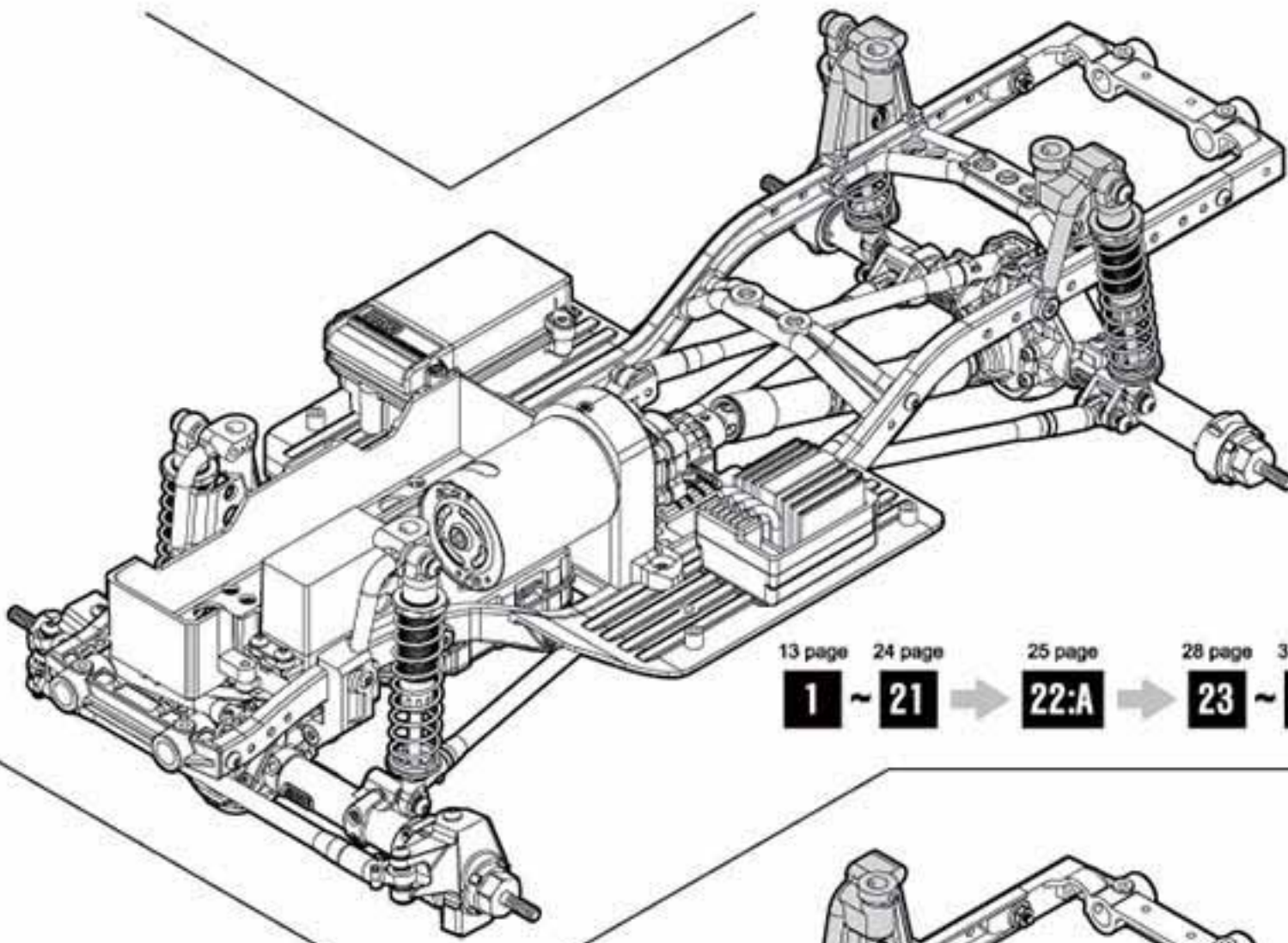

13 page 24 page 25 page 28 page 37 page 38 page 39 page 46 page 51 page
1 ~ 21 → **22:A** → **23 ~ 41** → **42 ~ 45** → **57 ~ 67**

REAR SHOCK RELOCATION

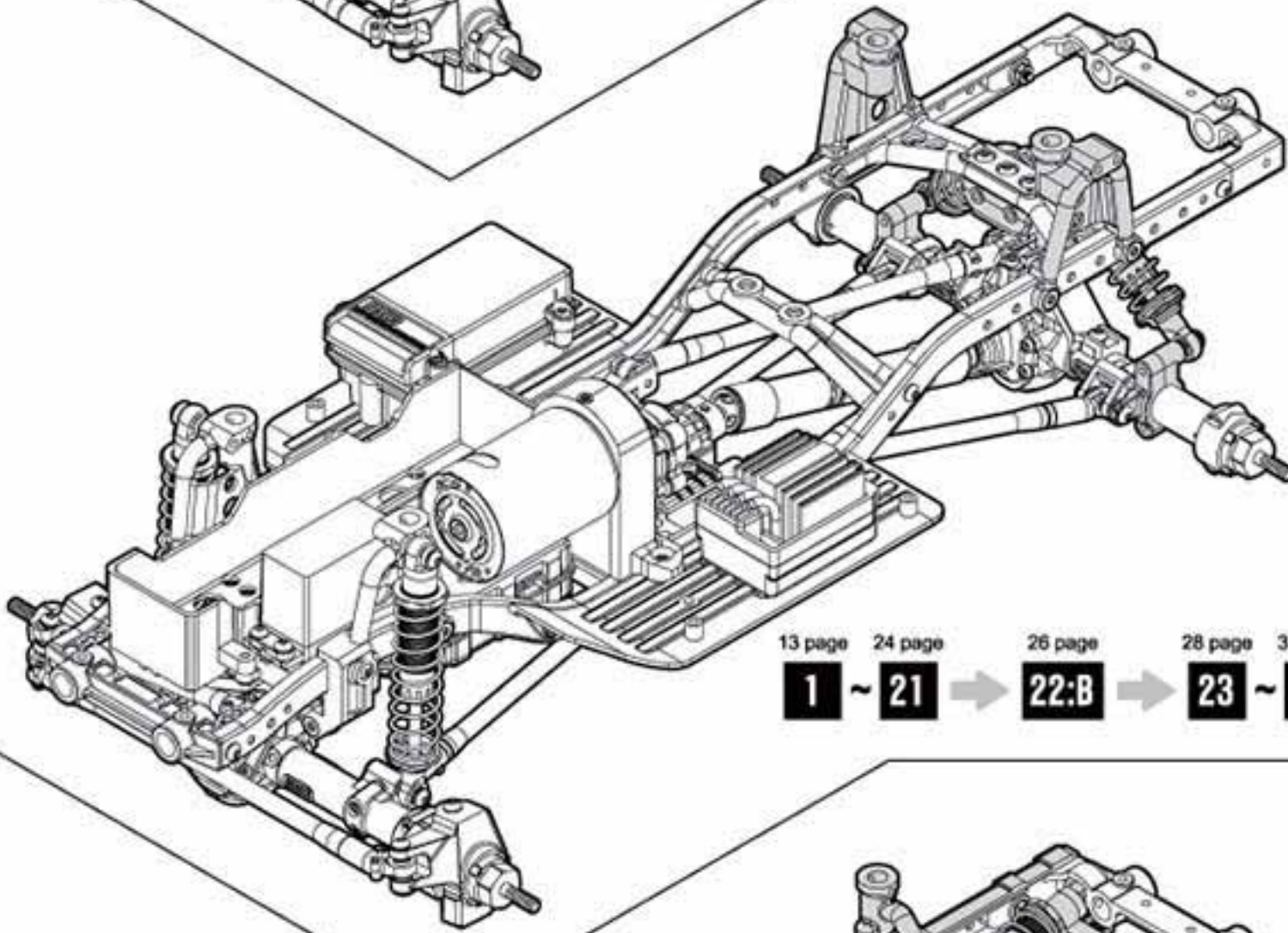

⚠ TA PRO kit only.

13 page 24 page 26 page 28 page 37 page 40 page 42 page 46 page 51 page
1 ~ 21 → **22:B** → **23 ~ 41** → **46 ~ 51** → **57 ~ 67**

REAR CANTILEVER

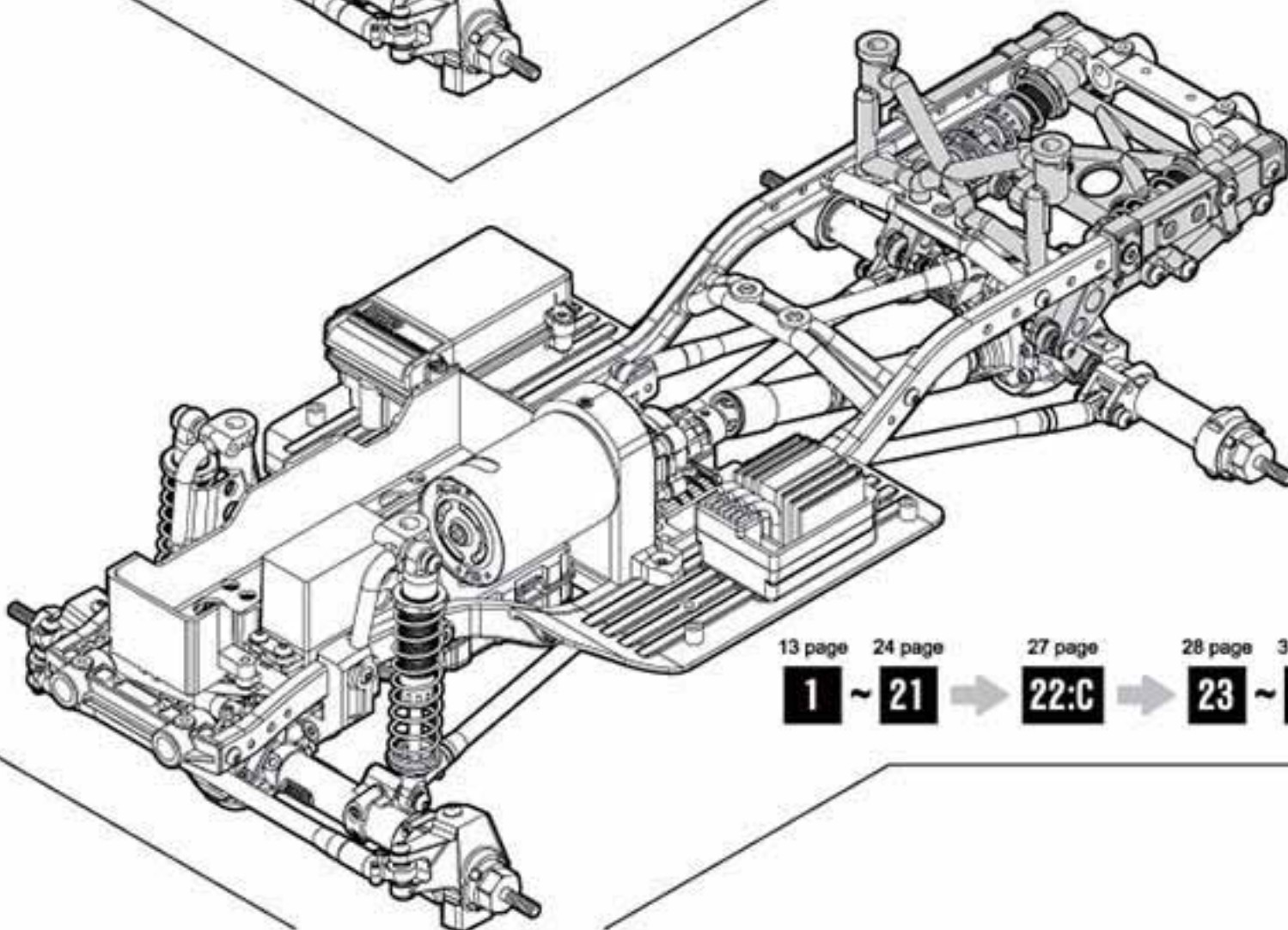

⚠ TA PRO kit only.

13 page 24 page 27 page 28 page 37 page 42 page 45 page 46 page 51 page
1 ~ 21 → **22:C** → **23 ~ 41** → **52 ~ 56** → **57 ~ 67**

AXLE

1

MAKEX 2



GM60068
33T Bevelgear



GM60064
Diff locker

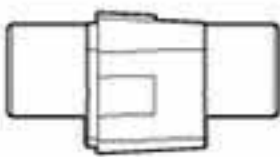

x2



GM30112
GA44 heavy duty diff locker

x2

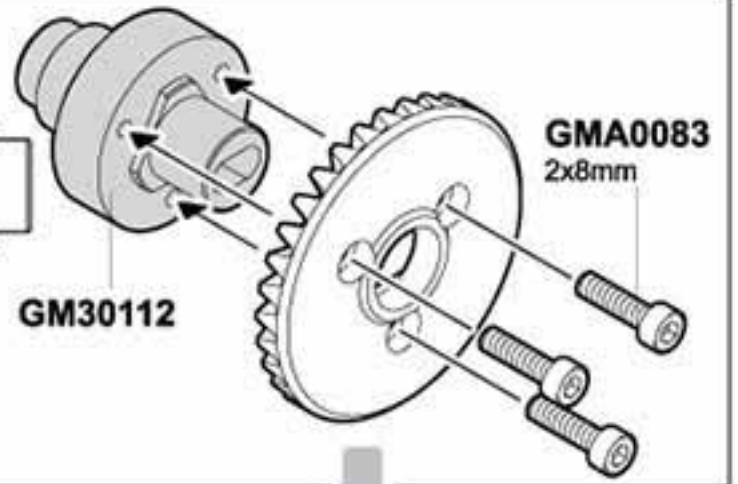

TA PRO kit only.

GMA0083
2x8mm



GMA0205
Ball bearing 8x12x3.5mm

x2

x4

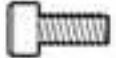

GMA0082
2x6mm Wrench bolt

x6

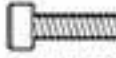

GMA0083
2x8mm Wrench bolt

x6

TS kit only.

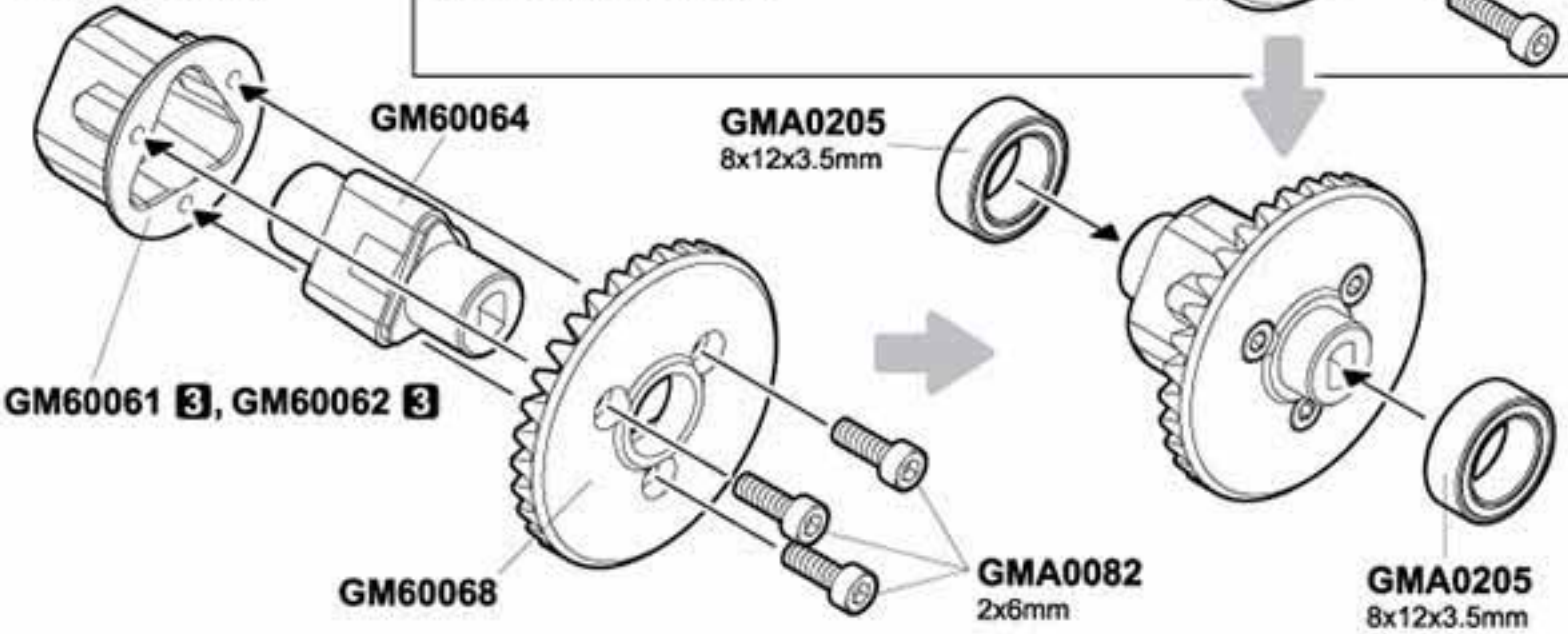

GM60064

GMA0205
8x12x3.5mm

GM60061 3, **GM60062** 3

GM60068

GMA0082
2x6mm

GMA0205
8x12x3.5mm

FRONT AXLE

2

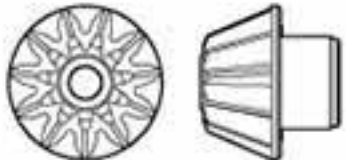

GM60067
11T Bevelgear



GMA0205
Ball bearing 8x12x3.5mm

x1

x1

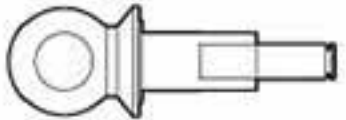

GM60111
Input universal joint 28mm

x1



GMA0165
Ball bearing 5x11x4mm

x1

x1



GMA0160
2mm E-ring

x1

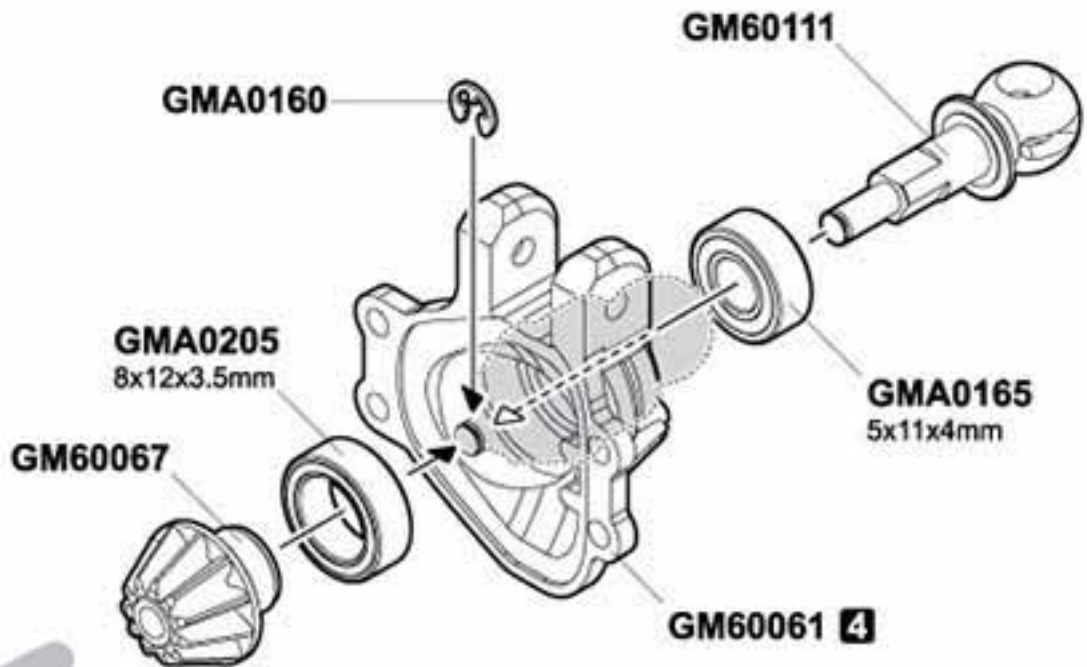

GMA0160

GM60111

GMA0205
8x12x3.5mm

GMA0165
5x11x4mm

GM60067

GM60061 4

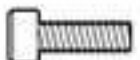

GMA0093
2.5x8mm Wrench bolt

x4

3

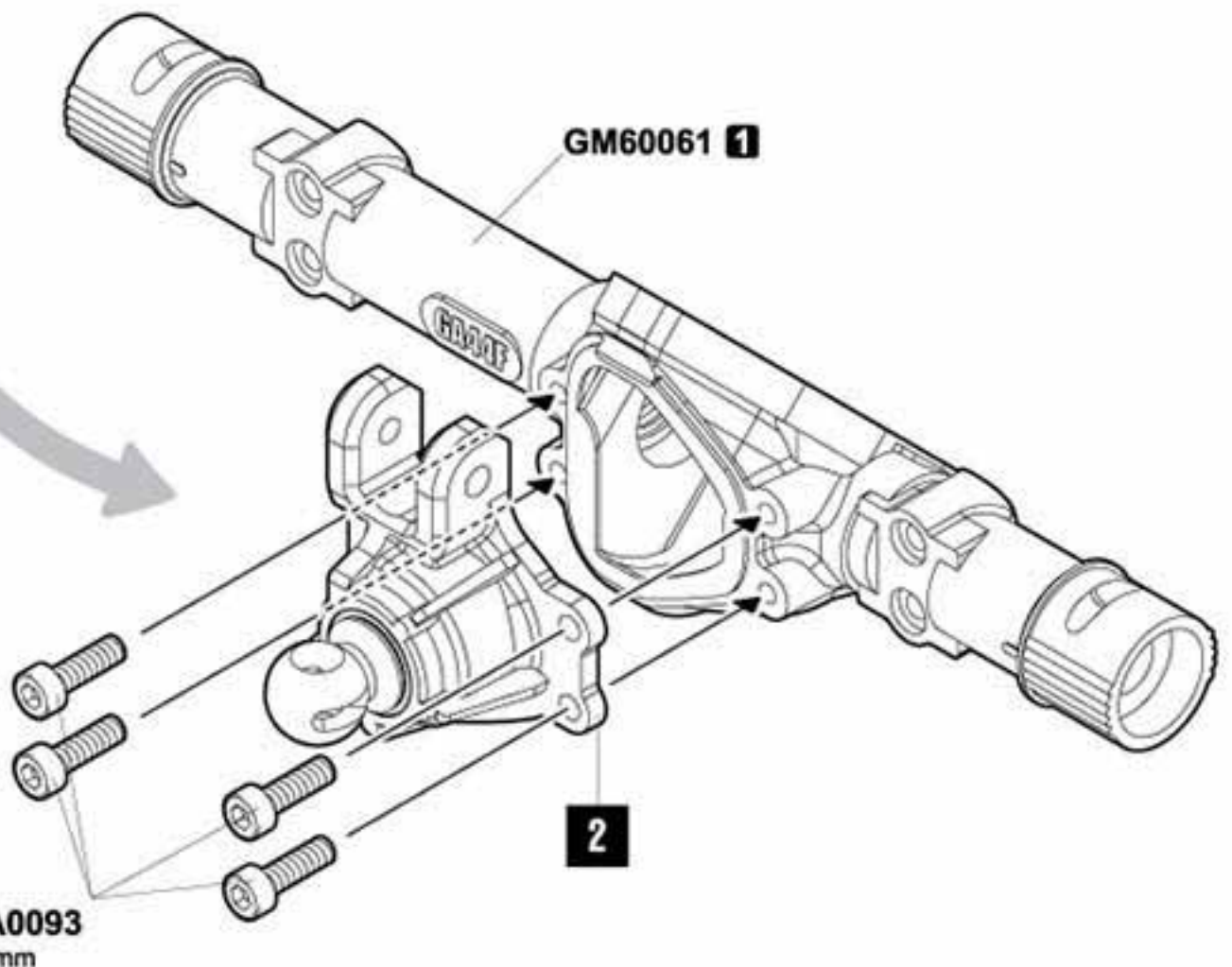

GM60061 1

GMA0093
2.5x8mm

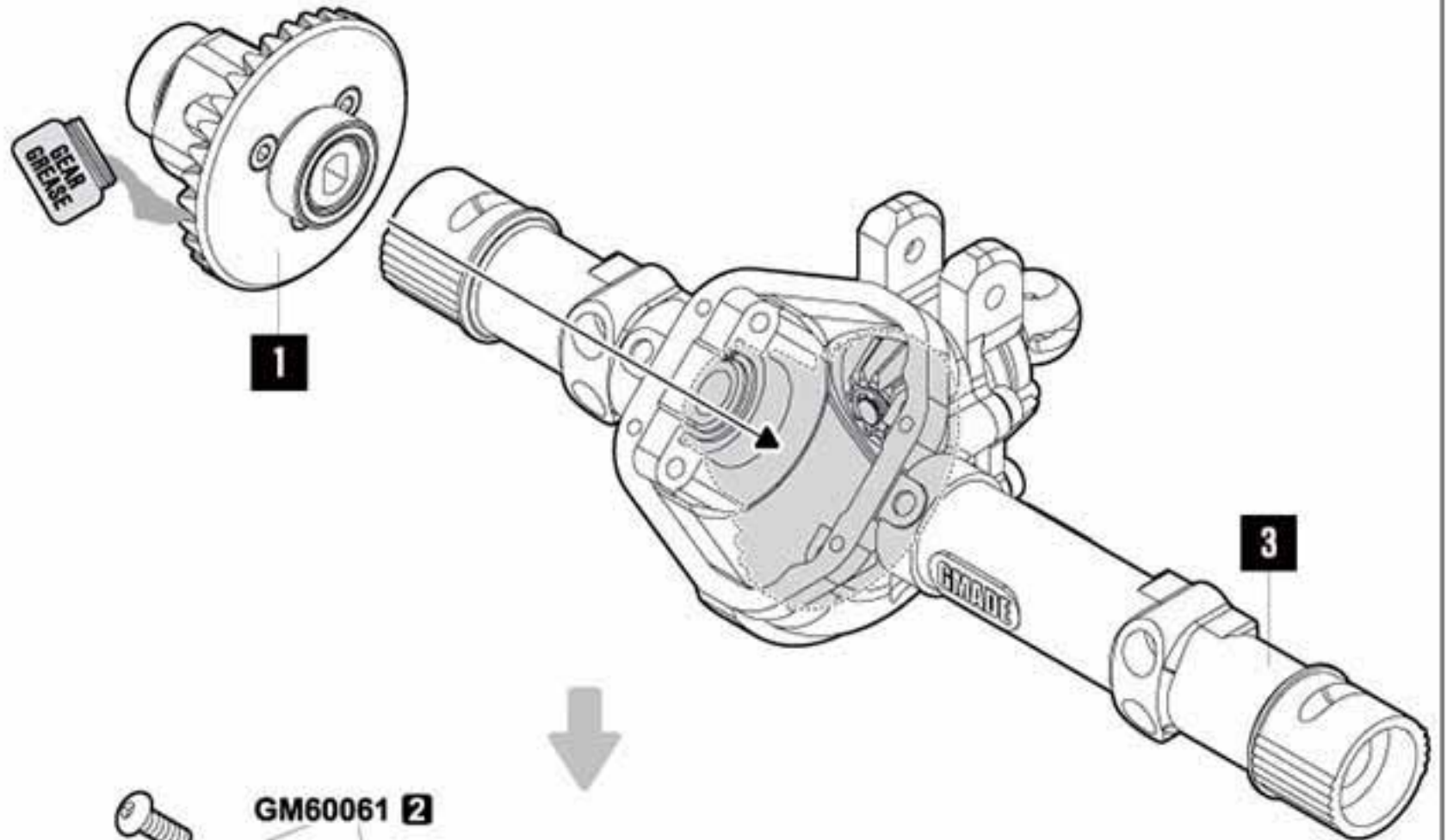

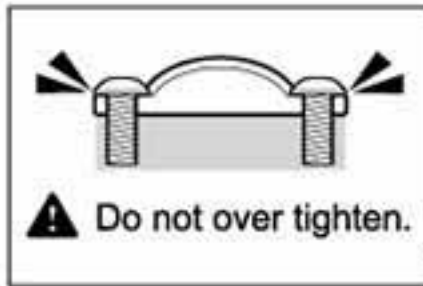
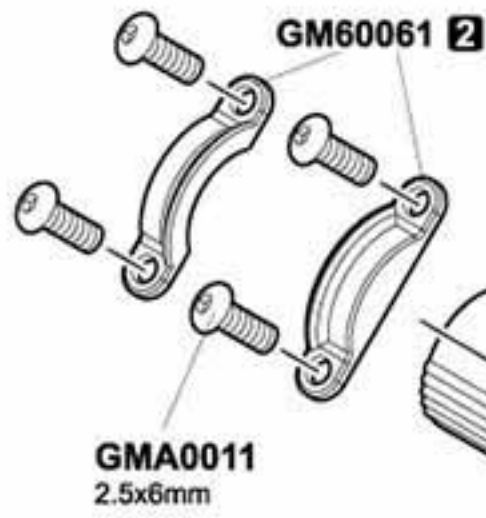

GMA0011
2.5x6mm
Round head wrench bolt

x4

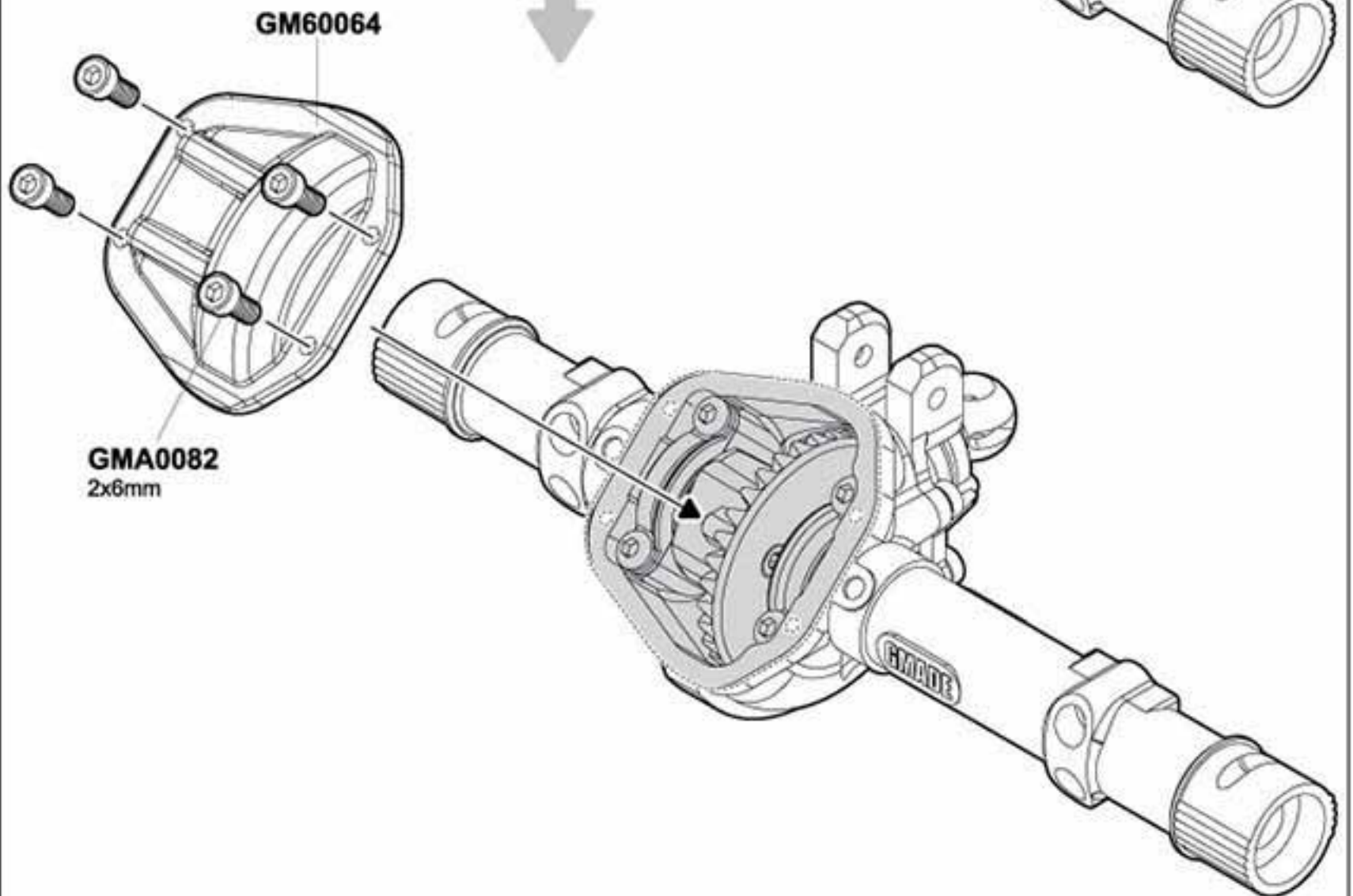

GMA0082
2x6mm Wrench bolt

x4



FRONT AXLE

5

RIGHT C-HUB CASTER ANGLE SETUP

RIGHT SIDE VIEW



GMA0165
Ball bearing 5x11x4mm

x2

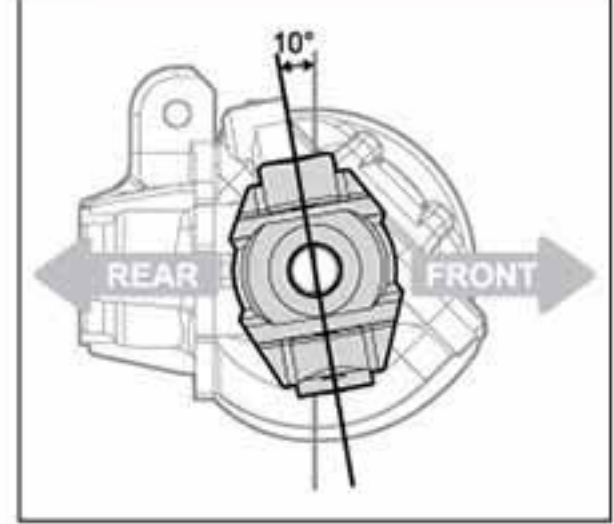
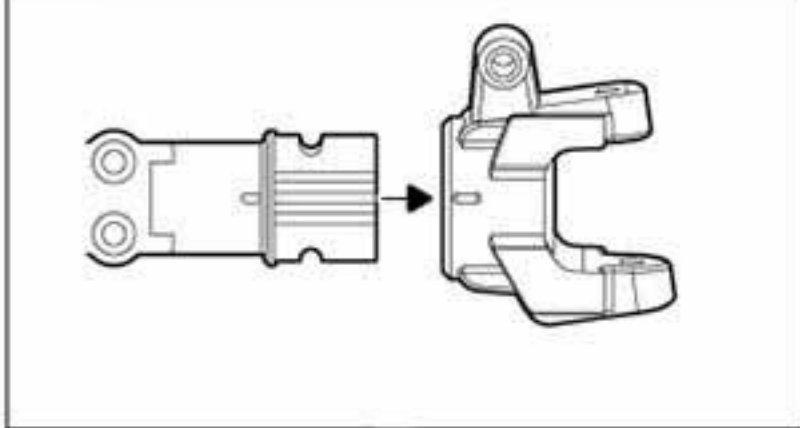

GM60063 2

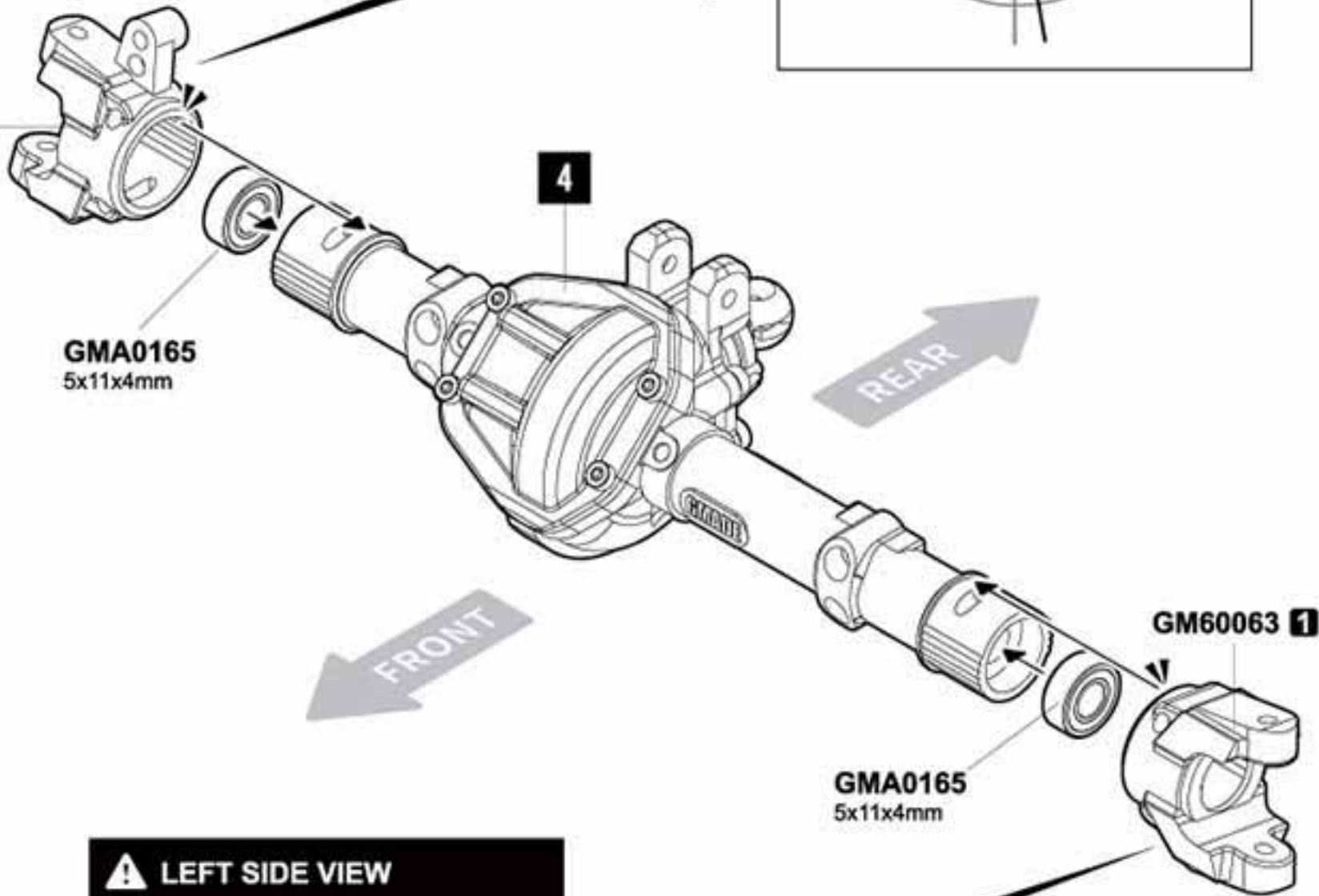

GMA0165
5x11x4mm

4

GM60063 1

GMA0165
5x11x4mm

LEFT SIDE VIEW

LEFT C-HUB CASTER ANGLE SETUP

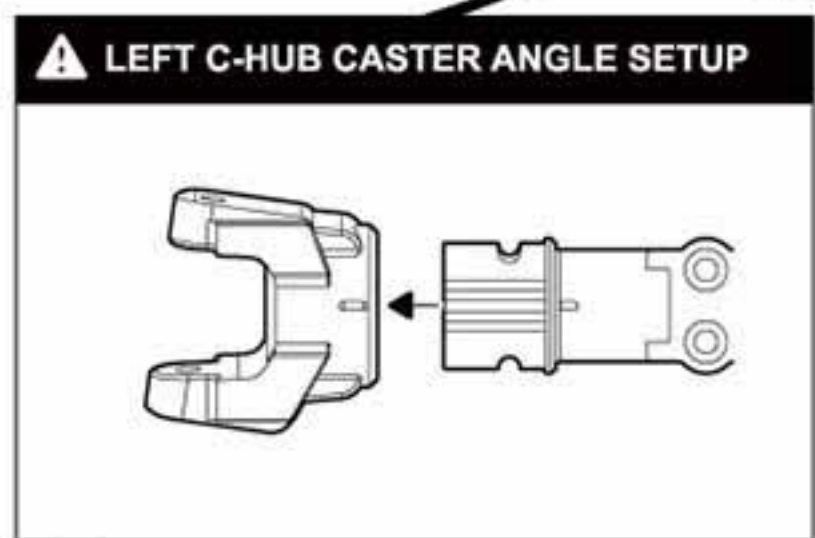
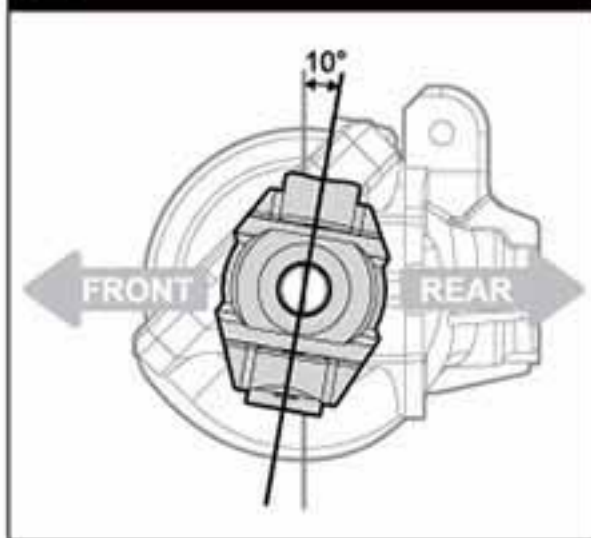

GMA0131
3x10mm Socket set screw

x4

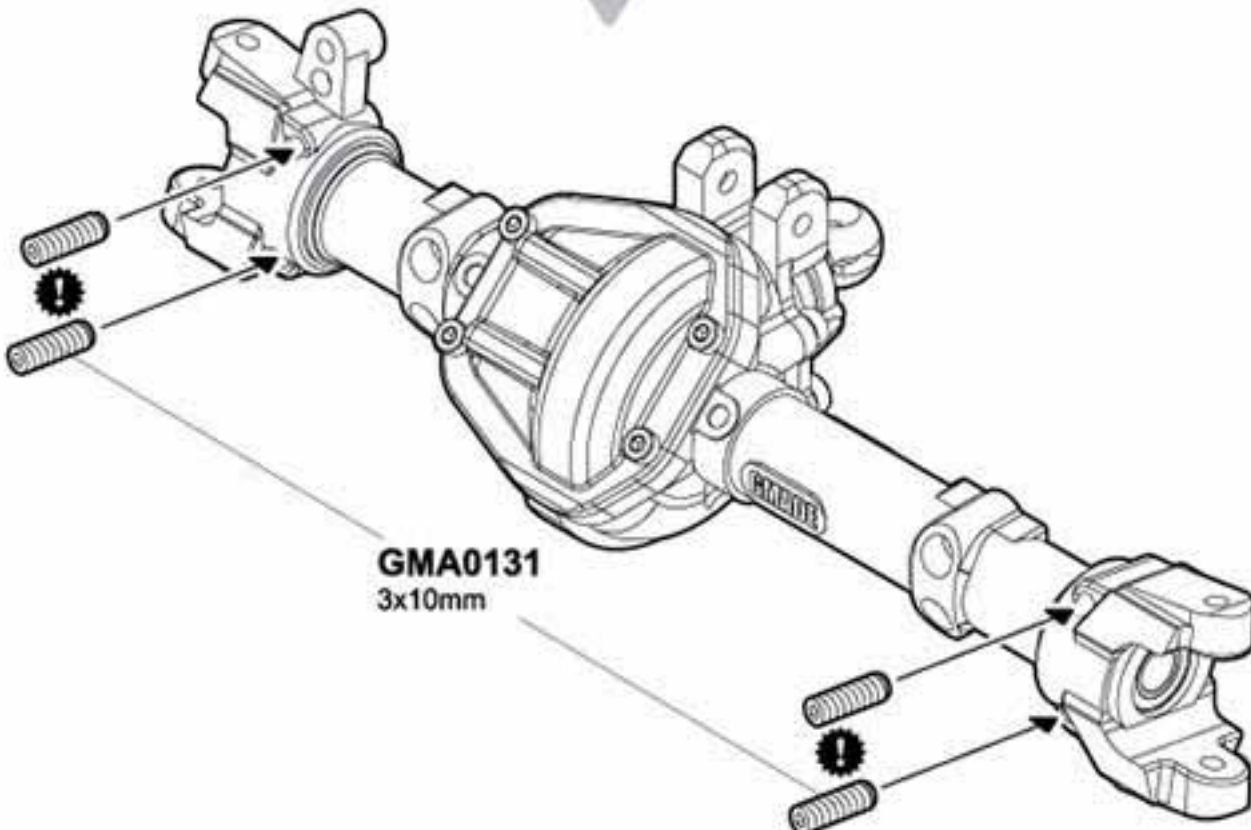

GMA0131
3x10mm

CAUTION

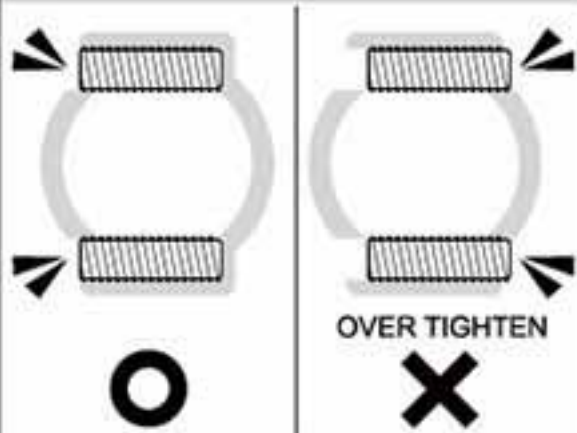

FRONT AXLE

6-A



GM60109
CVA drive shaft 64mm x1

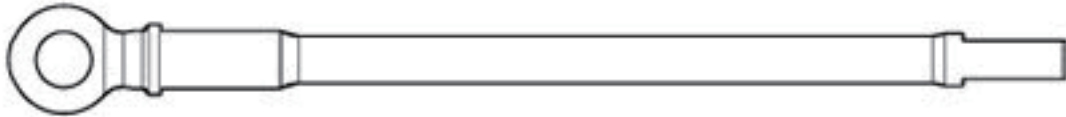

GM60109
CVA drive shaft 92mm x1

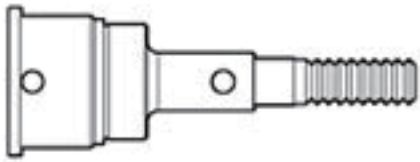

GM60109
CVA wheel axle shaft 35mm x2



GM60110
CVA pin retaining ring x2



GM60102
CVA drive coupler x2



GM60065
Pin 2x11.4mm x2

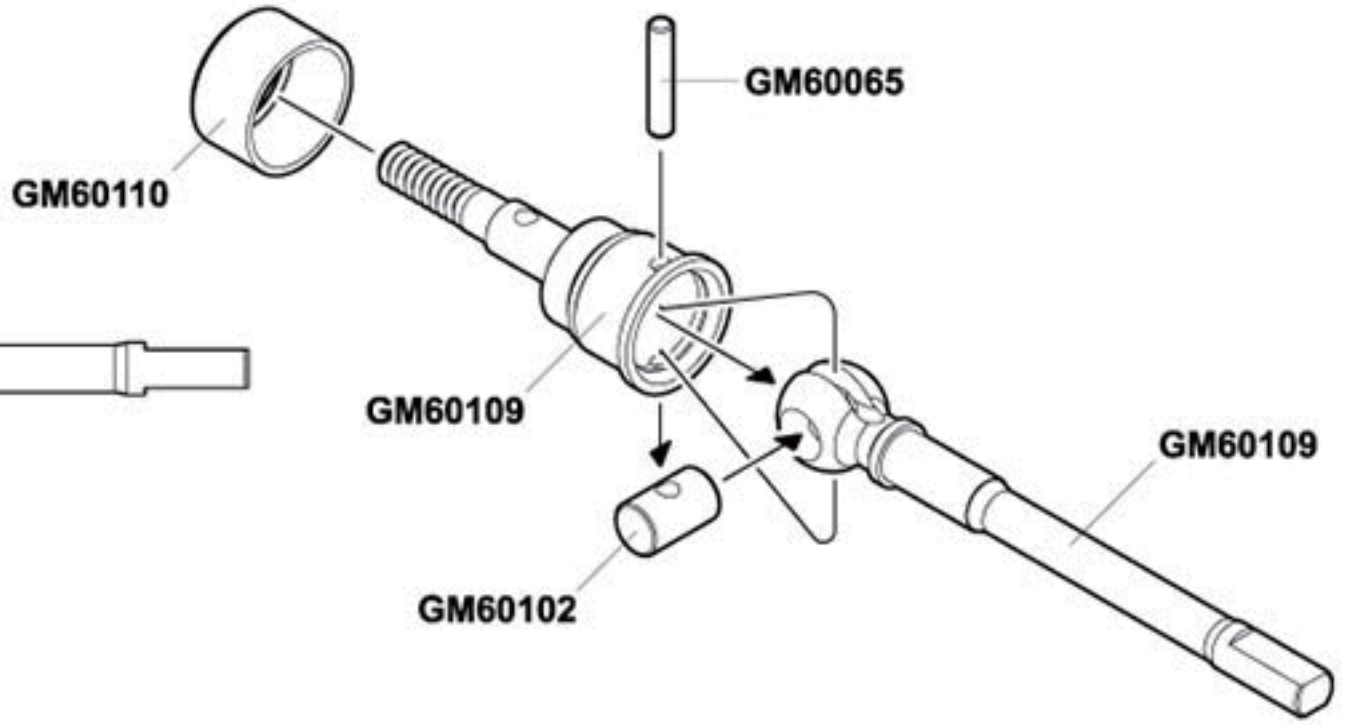

6-B

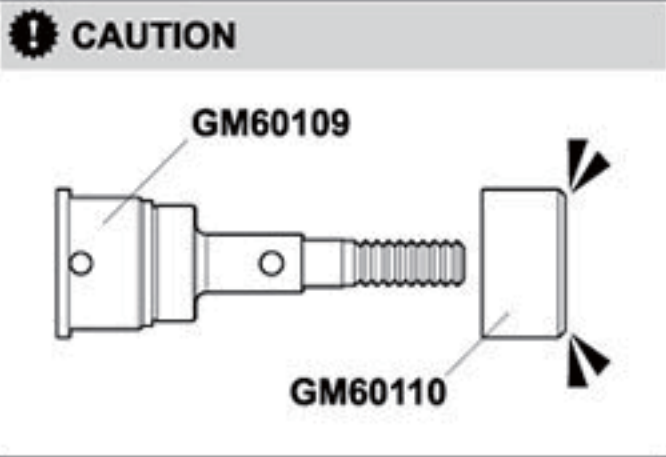
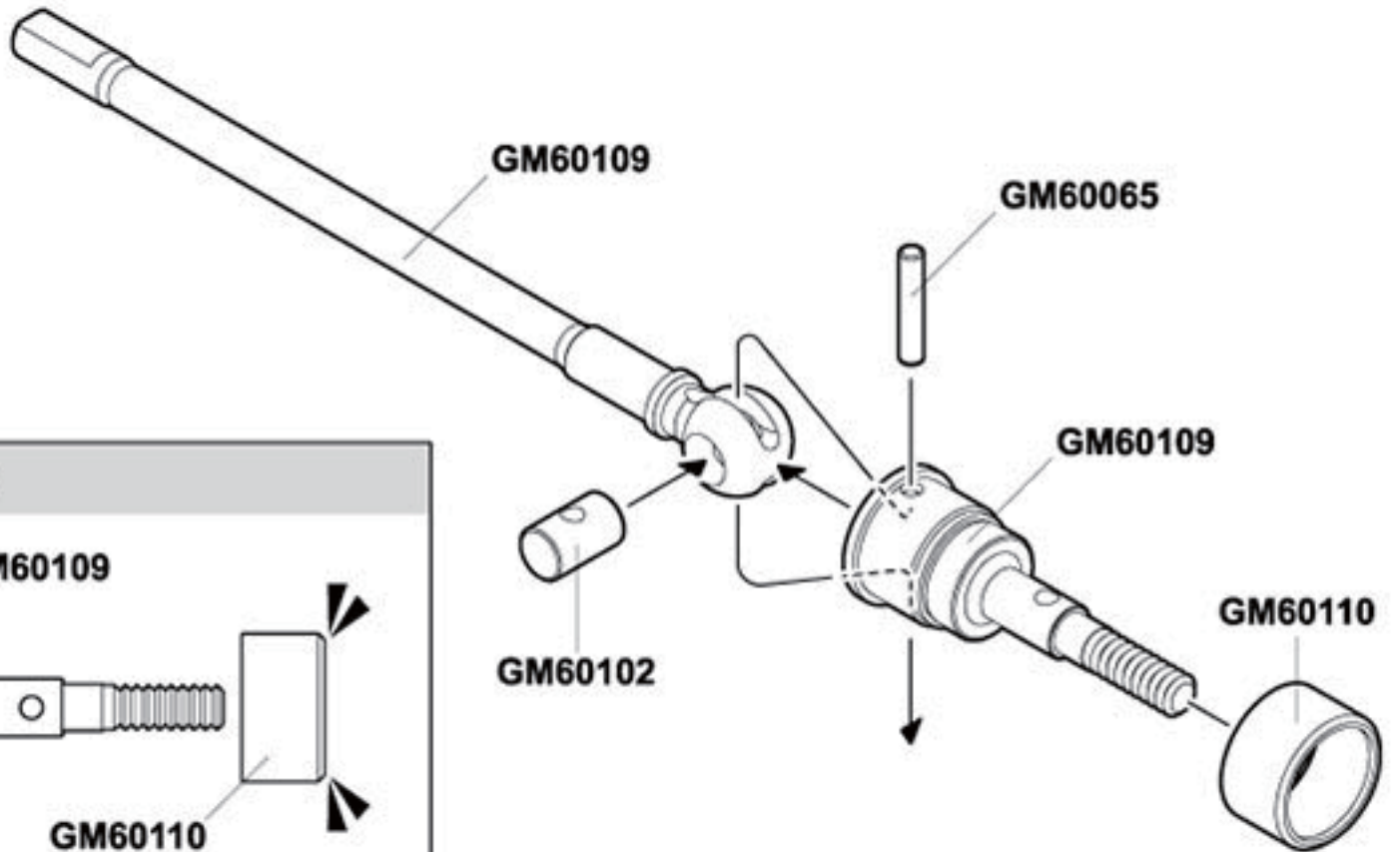

7

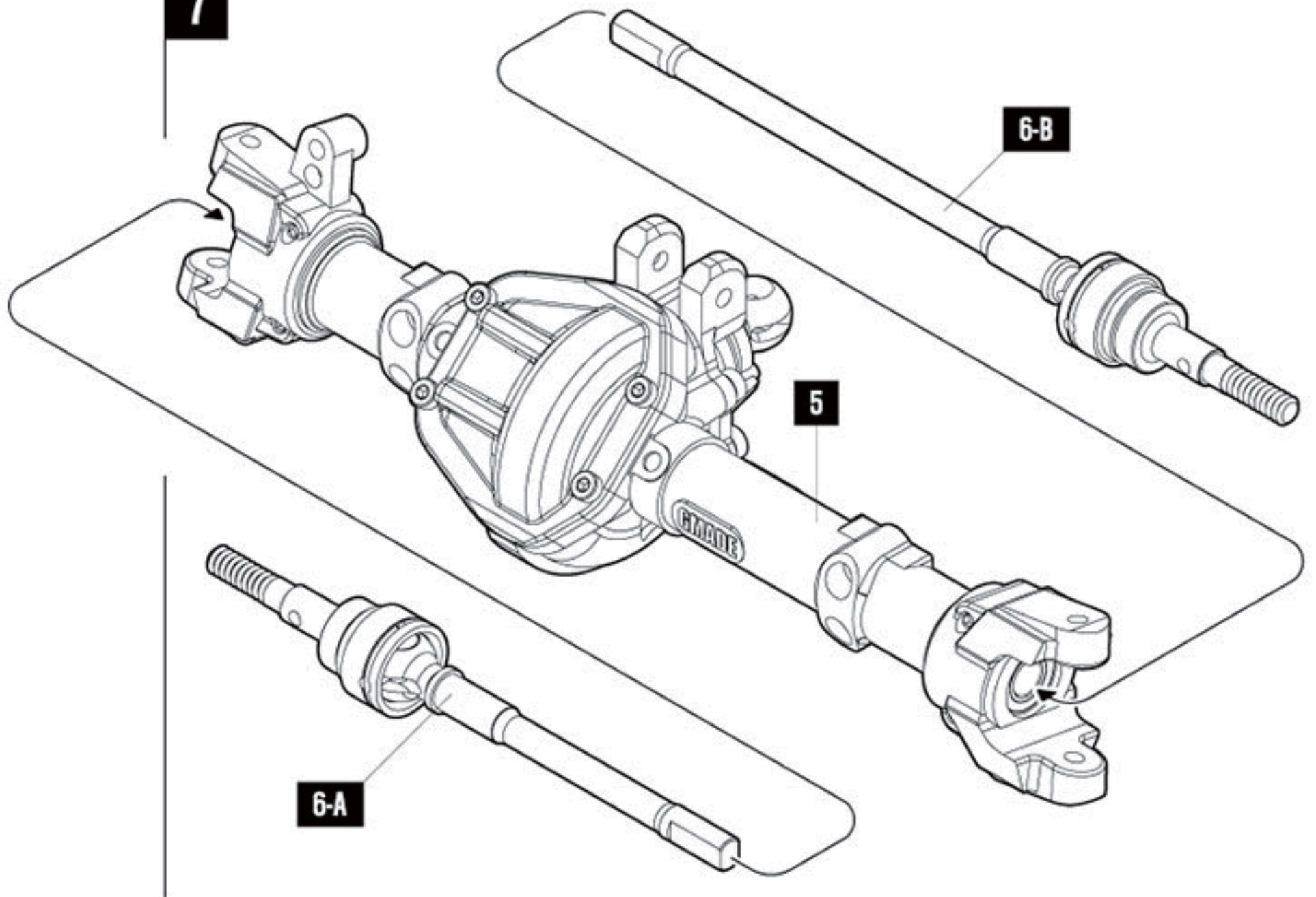

FRONT AXLE



GMA0019
3x10mm
Round head wrench bolt

x4

8

GMA0165
5x11x4mm

GM60063 4

GM60023 3

GMA0167
10x15x4mm

GMA0167
10x15x4mm

GM60023 3

GMA0165
5x11x4mm

GM60063 3

GMA0019
3x10mm

7

GMA0019
3x10mm

GMA0019
3x10mm



GMA0165
Ball bearing 5x11x4mm

x2



GMA0167
Ball bearing 10x15x4mm

x2

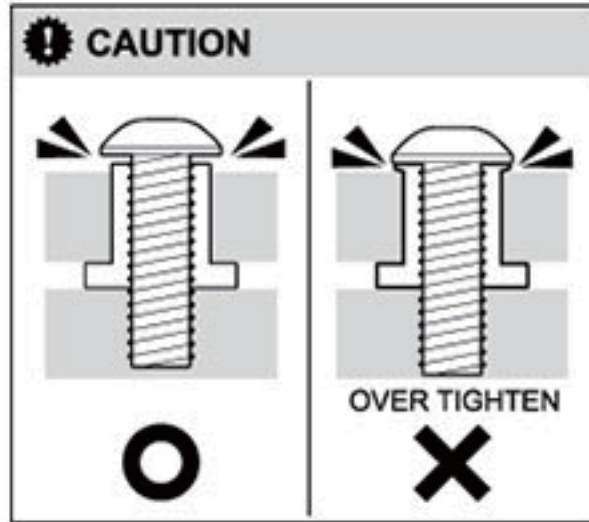

GMA0019
3x10mm

9



GMA0095
2.5x12mm Wrench bolt

x4

GM60061 5

8

GMA0095
2.5x12mm

REAR AXLE

10

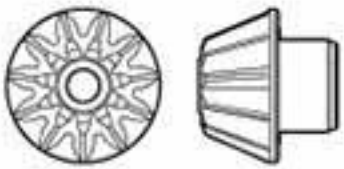

GM60067
11T Bevelgear x1

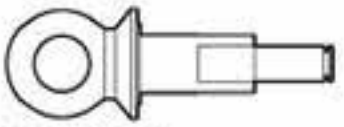

GM60111
Input universal joint 28mm x1



GMA0160
2mm E-ring x1



GMA0165
Ball bearing 5x11x4mm x1



GMA0205
Ball bearing 8x12x3.5mm x1

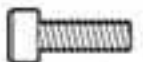

GMA0093
2.5x8mm Wrench bolt x4

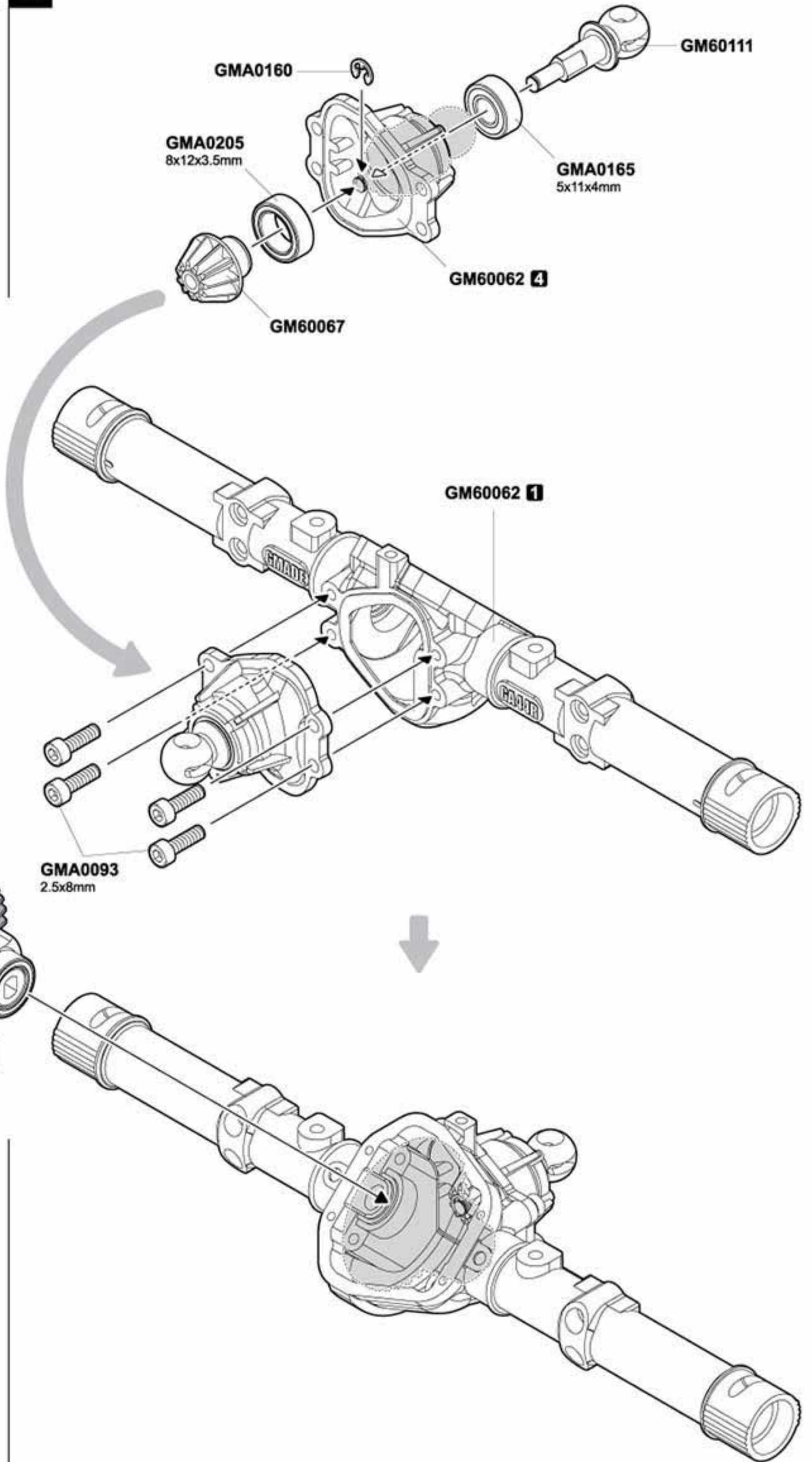

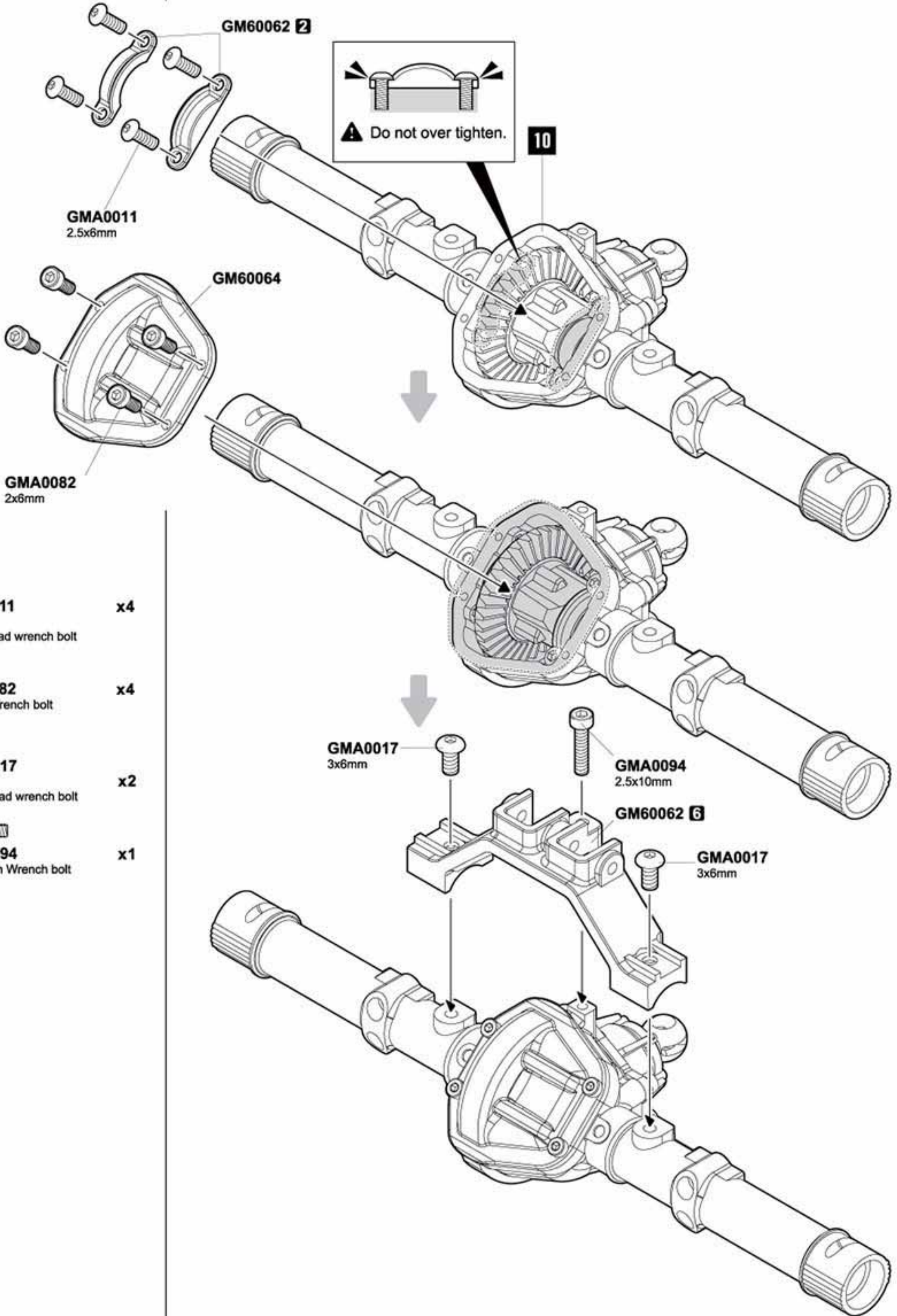

-  **GMA0011** **x4**
2.5x6mm
Round head wrench bolt
-  **GMA0082** **x4**
2x6mm Wrench bolt
-  **GMA0017** **x2**
3x6mm
Round head wrench bolt
-  **GMA0094** **x1**
2.5x10mm Wrench bolt

REAR AXLE

12

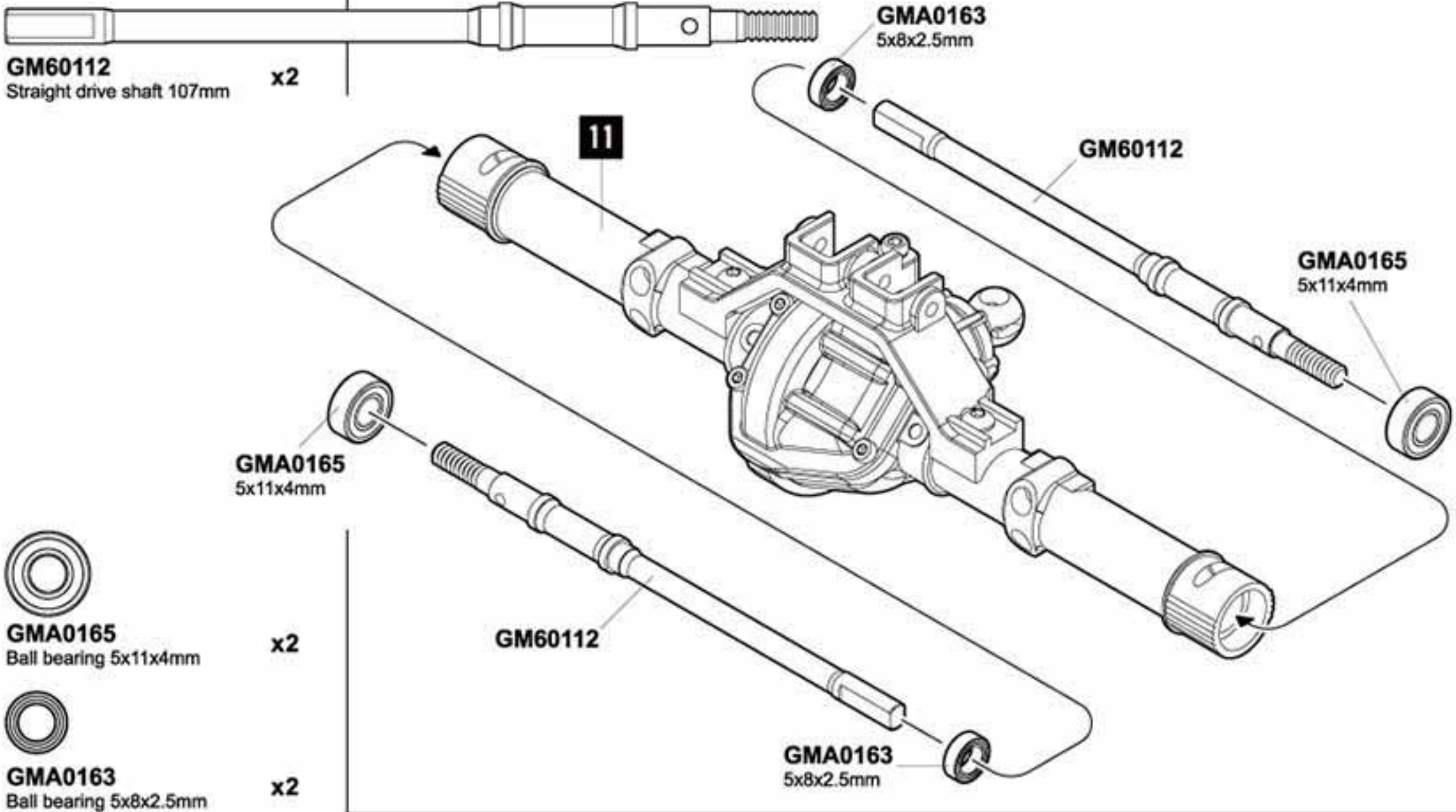

13

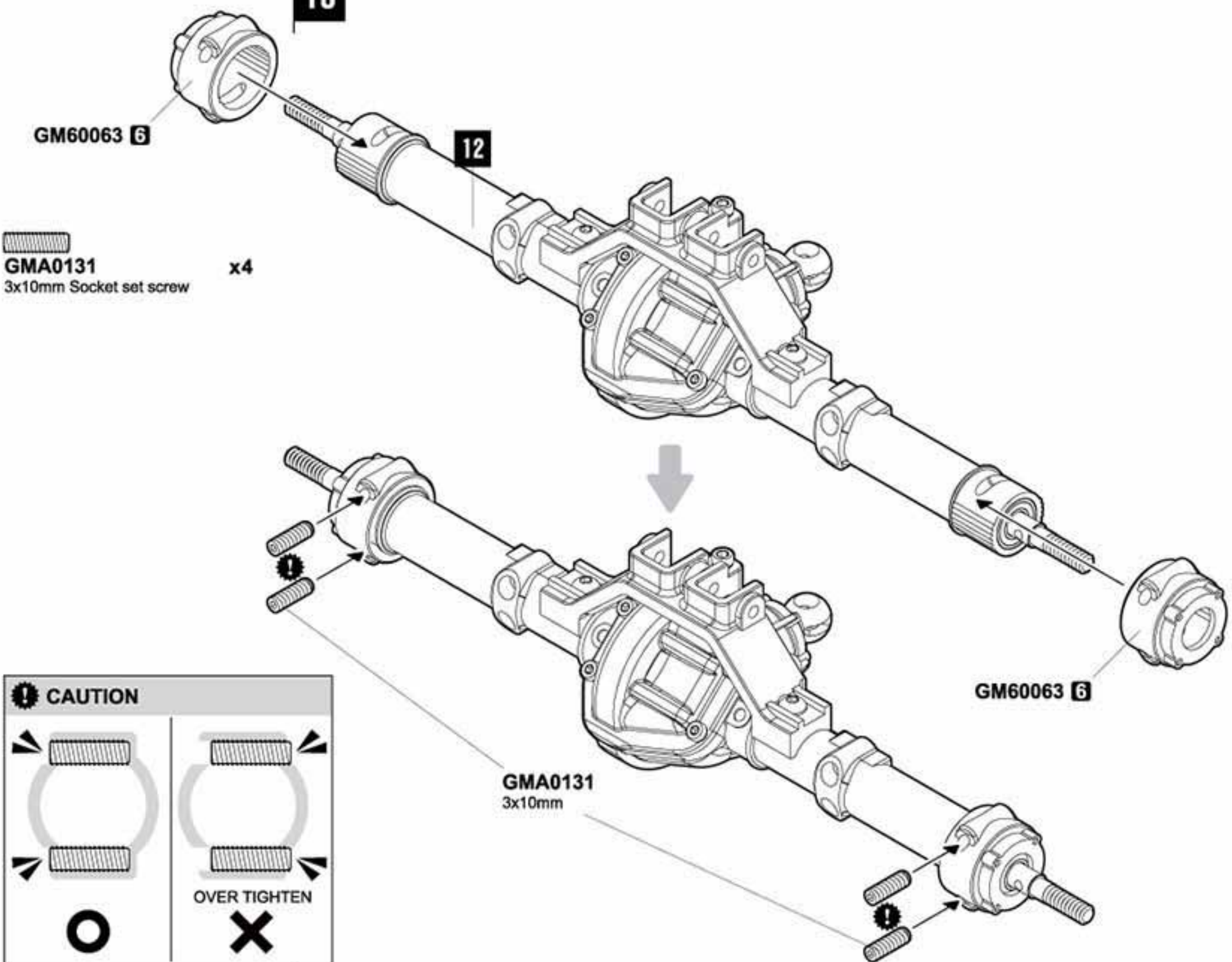

TRANSMISSION

14

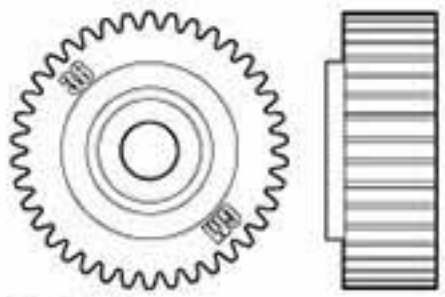

- GM60071**
48P 38T 1st gear (LO) x1
- GM60033**
Pin 1.5x7.2mm x2
- GMA0162**
4mm E-ring x2
- GMA0163**
Ball bearing 5x8x2.5mm x1
- GMA0165**
Ball bearing 5x11x4mm x3

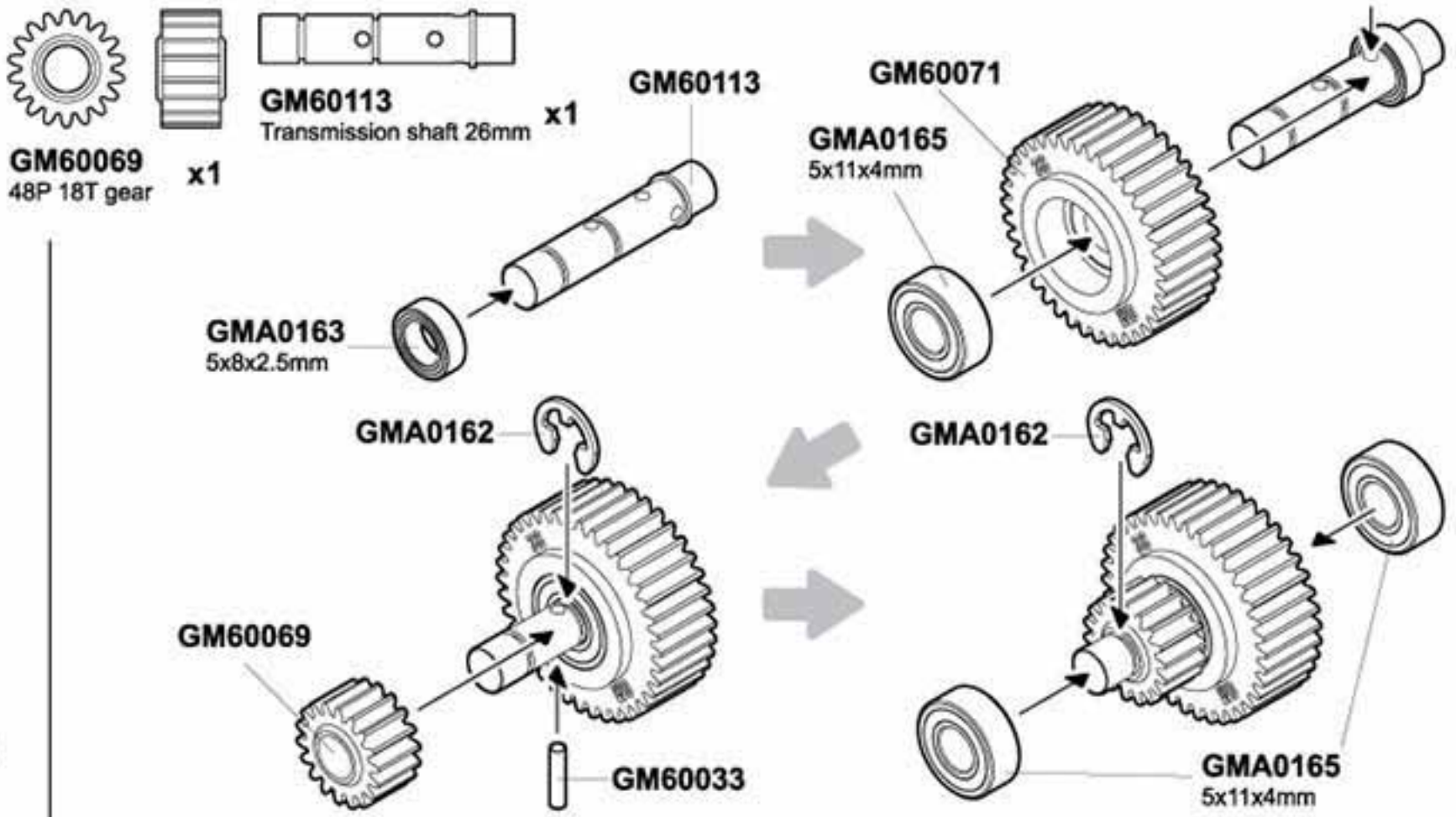

15

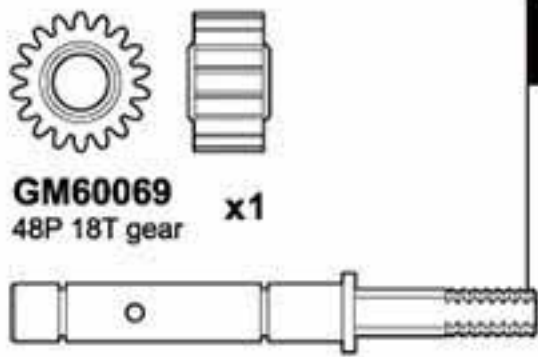

- GM60069**
48P 18T gear x1
- GM60114**
Slipper shaft 46mm x1
- GM60033**
Pin 1.5x7.2mm x1
- GMA0162**
4mm E-ring x2

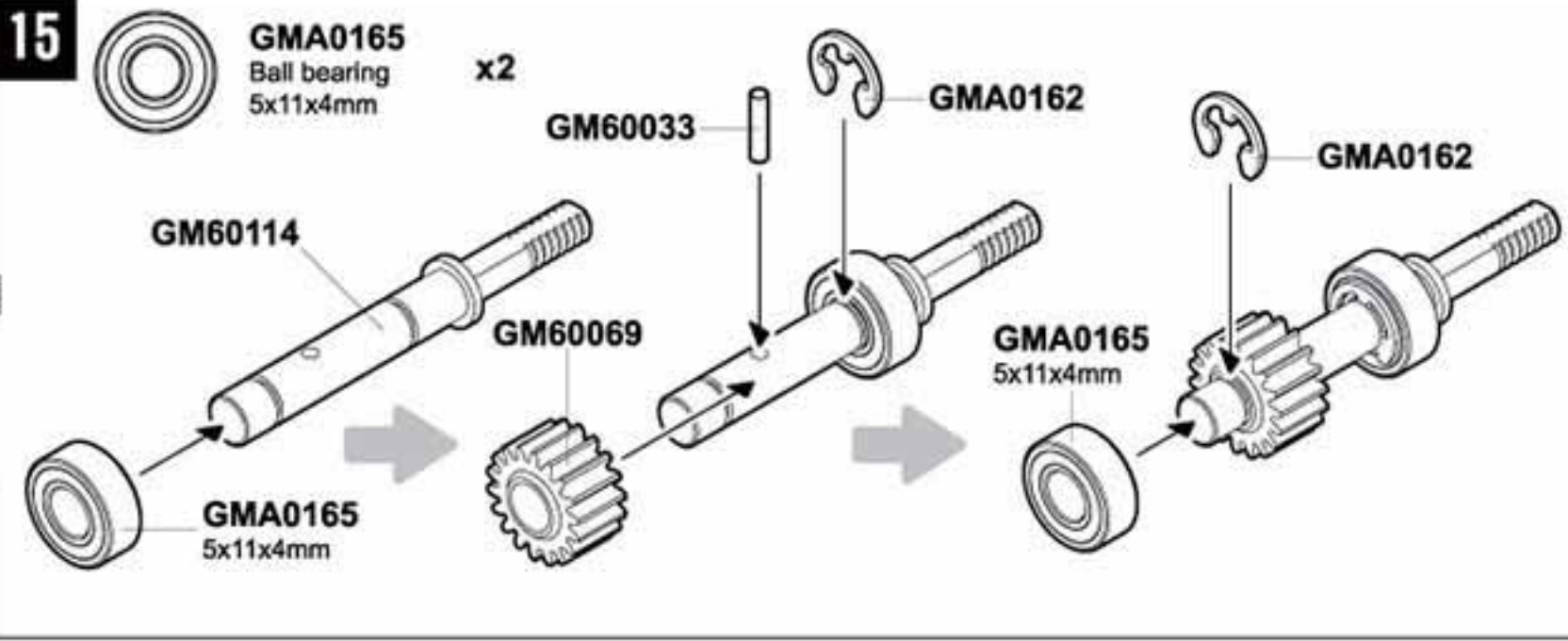

16

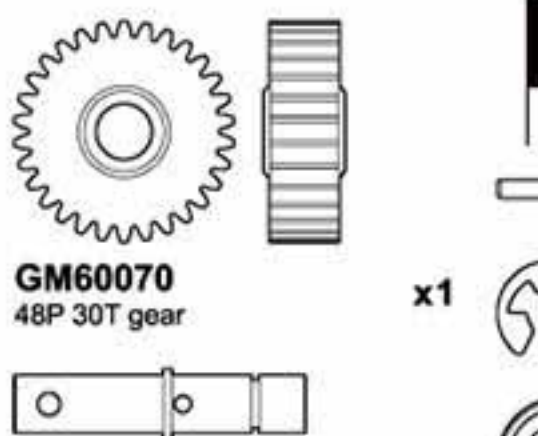

- GM60070**
48P 30T gear x1
- GM60115**
Transmission output front shaft 25mm x1
- GM60033**
Pin 1.5x7.2mm x1
- GMA0162**
4mm E-ring x1
- GMA0165**
Ball bearing 5x11x4mm x2

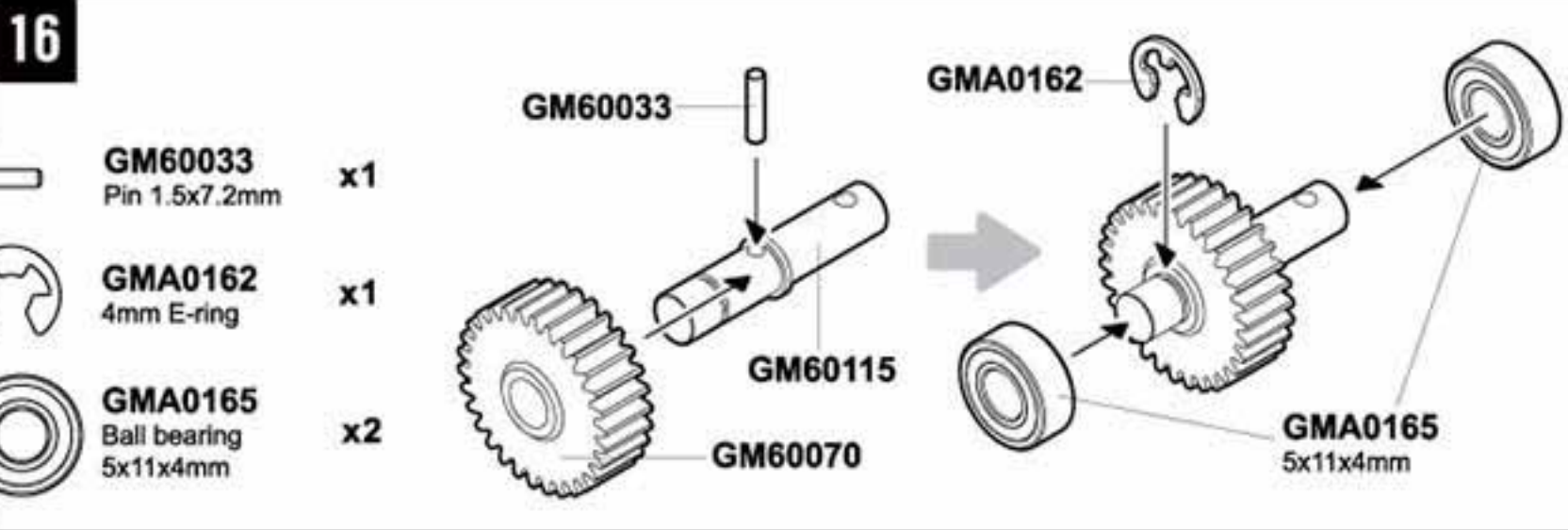

17

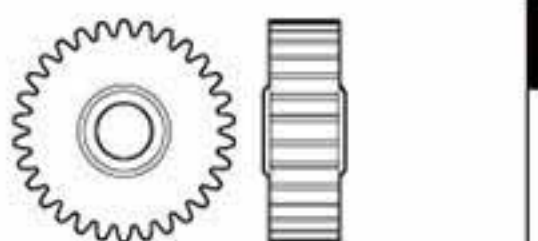

- GM60070**
48P 30T gear x1
- GM60116**
Transmission output rear shaft 63mm x1
- GM60033**
Pin 1.5x7.2mm x1
- GMA0162**
4mm E-ring x1
- GMA0165**
Ball bearing 5x11x4mm x2

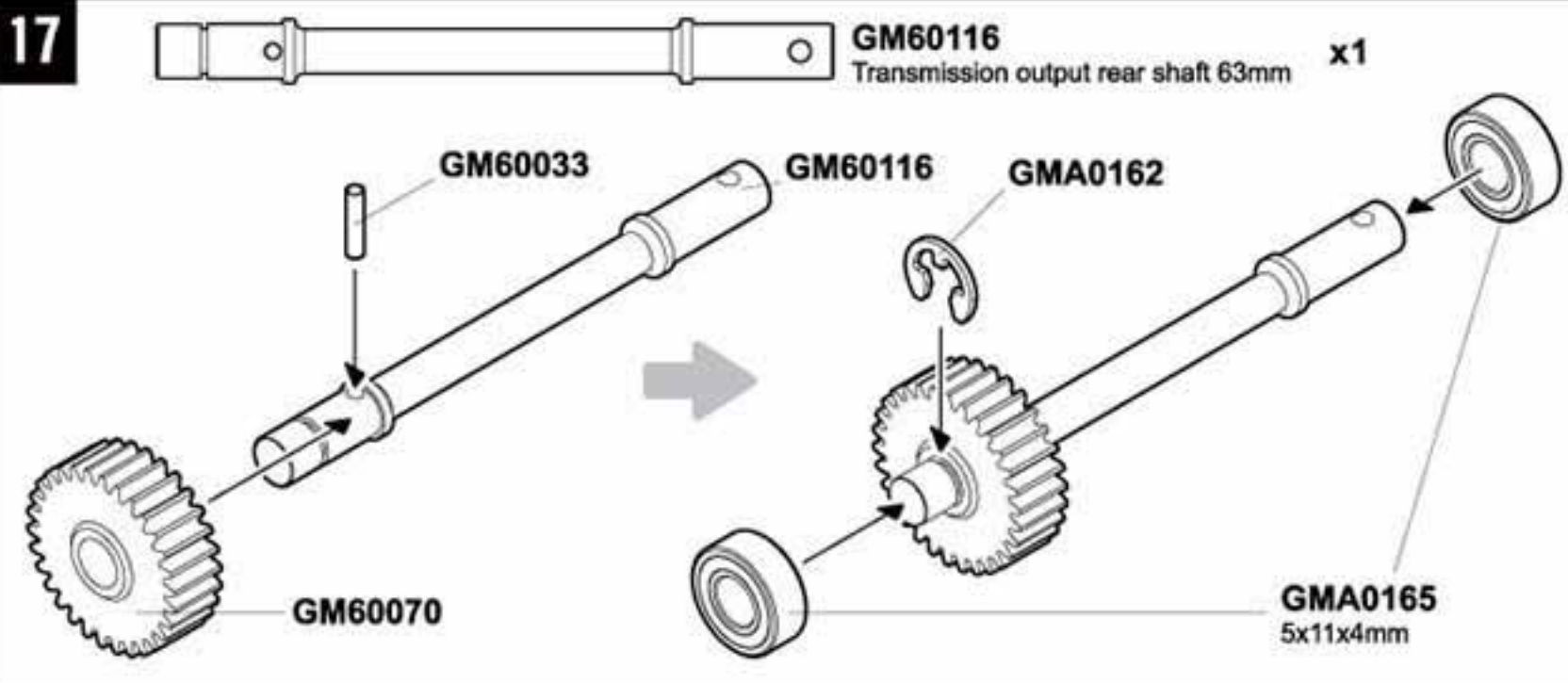

TRANSMISSION

18



GMA0093
2.5x8mm Wrench bolt

x6

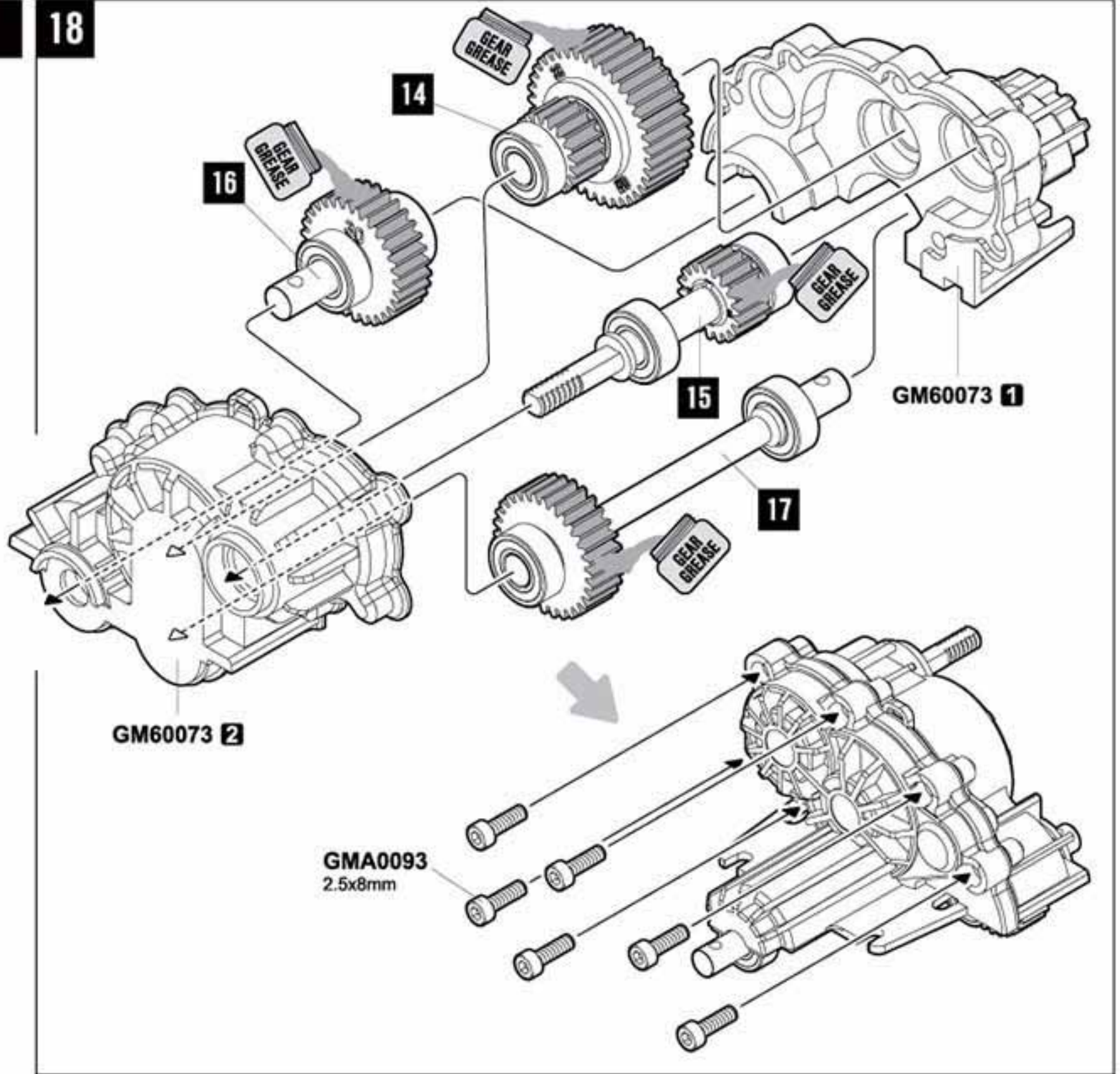

19



GM60080A
32P 45T Spur gear

x1



GMA0210
4mm conical spring washer

x4



GMA0159
4mm Washer

x1



GMA0157
M4 nylon lock nut

x1



GMA0210



GM60088
Slipper pad

x2

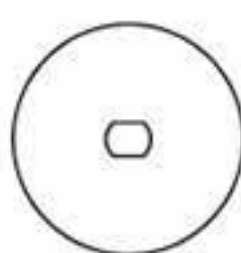

GM60087
Slipper disk 20x1.5mm

x2

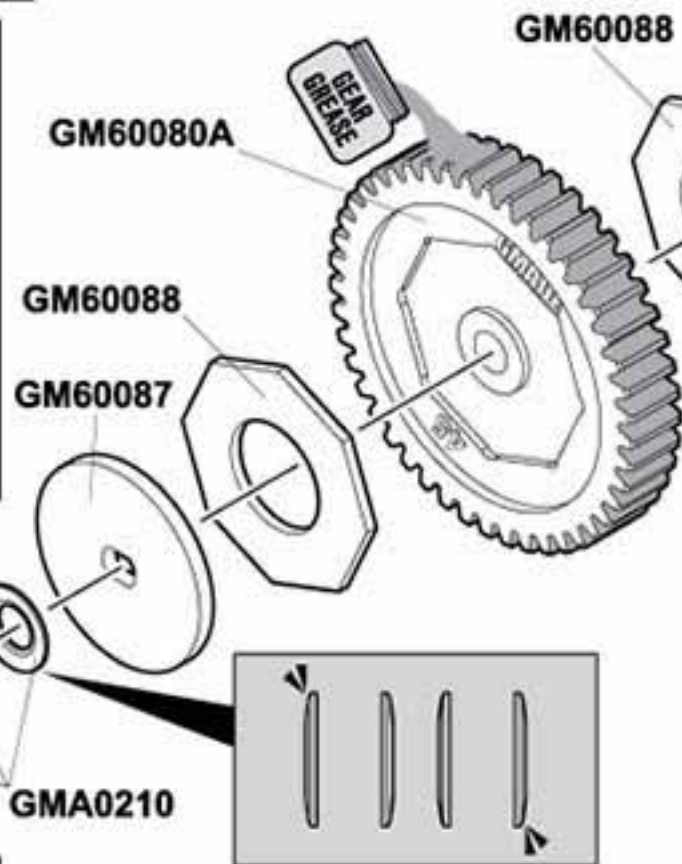

18

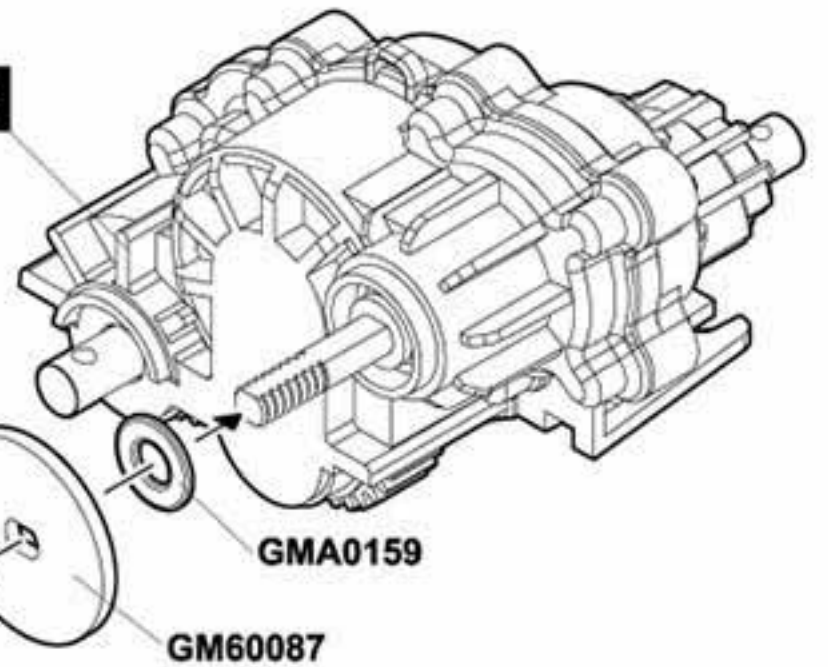

⚠ Fully tighten the nut, and loosen the nut 1/8 ~ 3/8 of a turn.

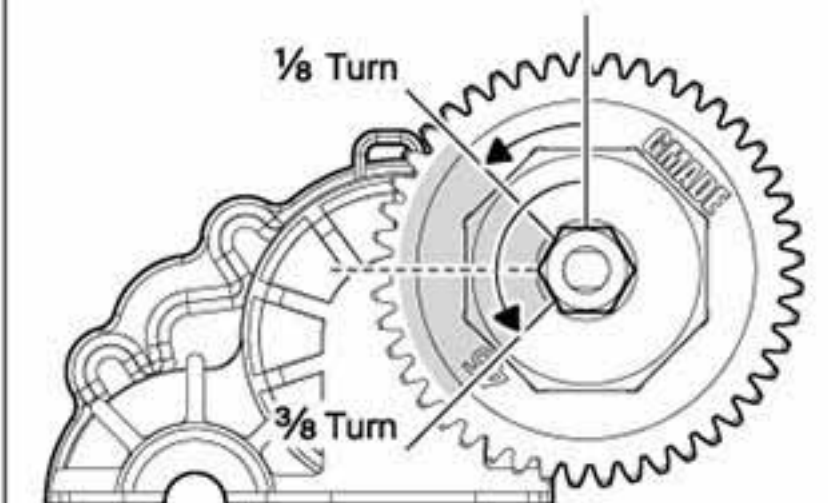



GMA0211 x4
3x18mm Flat head wrench bolt

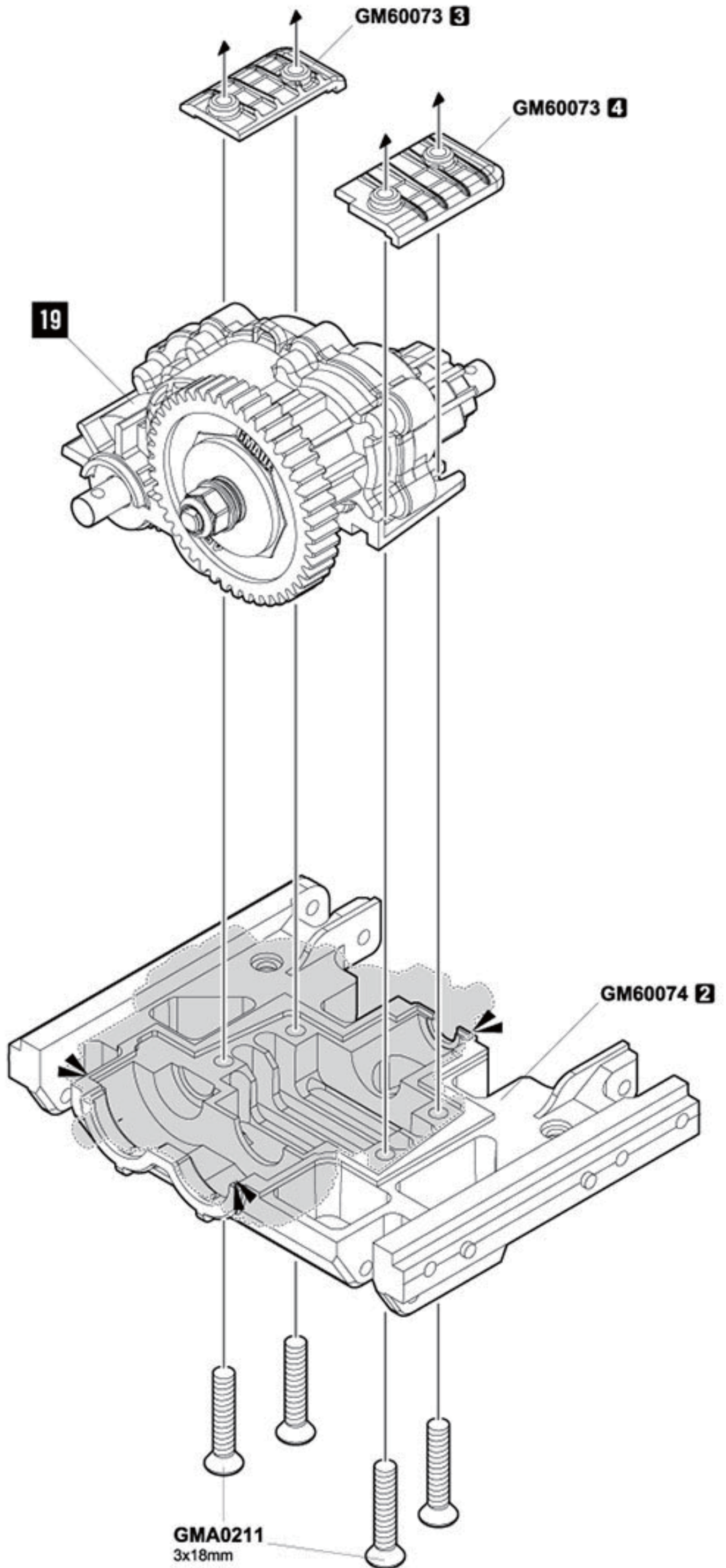

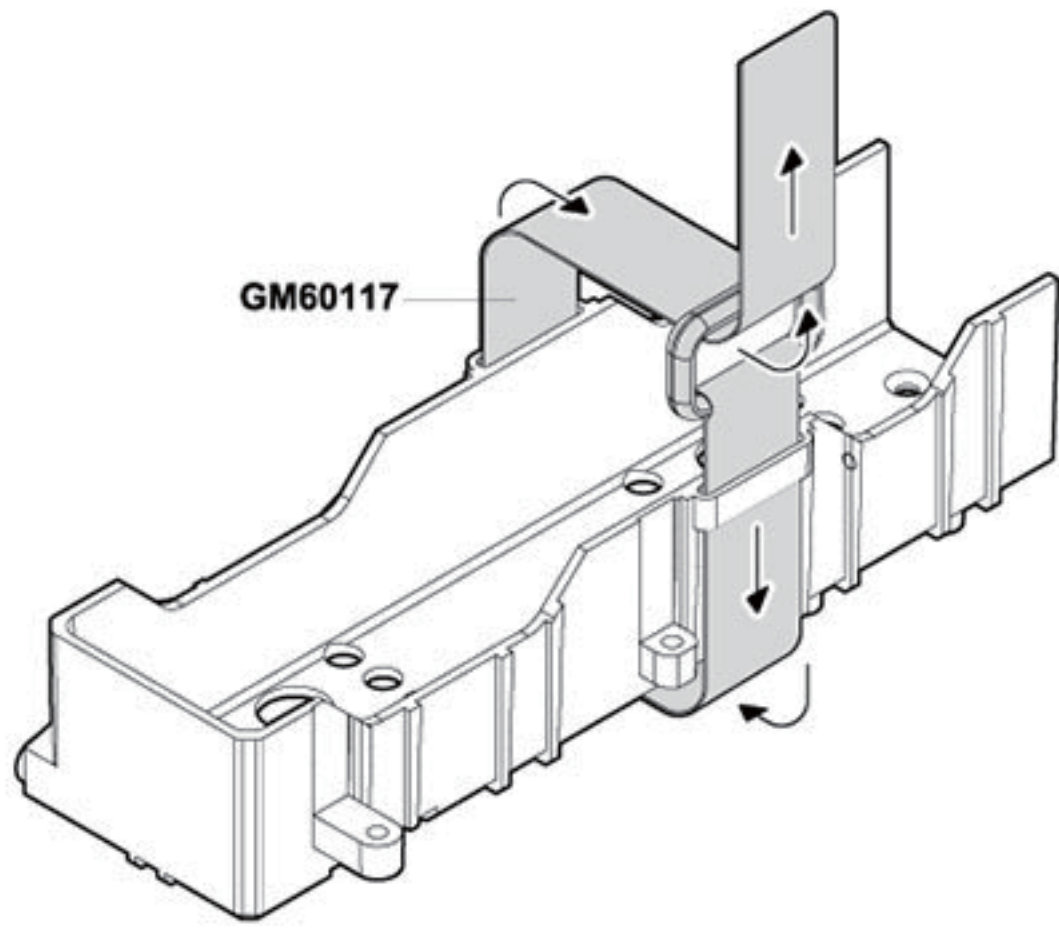

⚠ INSTALL VELCRO STRAP BEFORE BATTERY TRAY IS INSTALLED.



-  **GMA0018**
3x8mm
Round head wrench bolt x4
 -  **GMA0020**
3x12mm
Round head wrench bolt x4
 -  **GMA0154**
M3 Nut x1
 -  **GM60093**
5.8mm ball stud M3x5mm x1
- 
⚠ Set to the neutral position before attaching the servo horn to the servo.



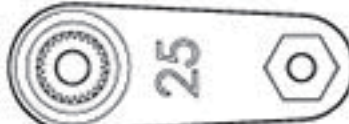

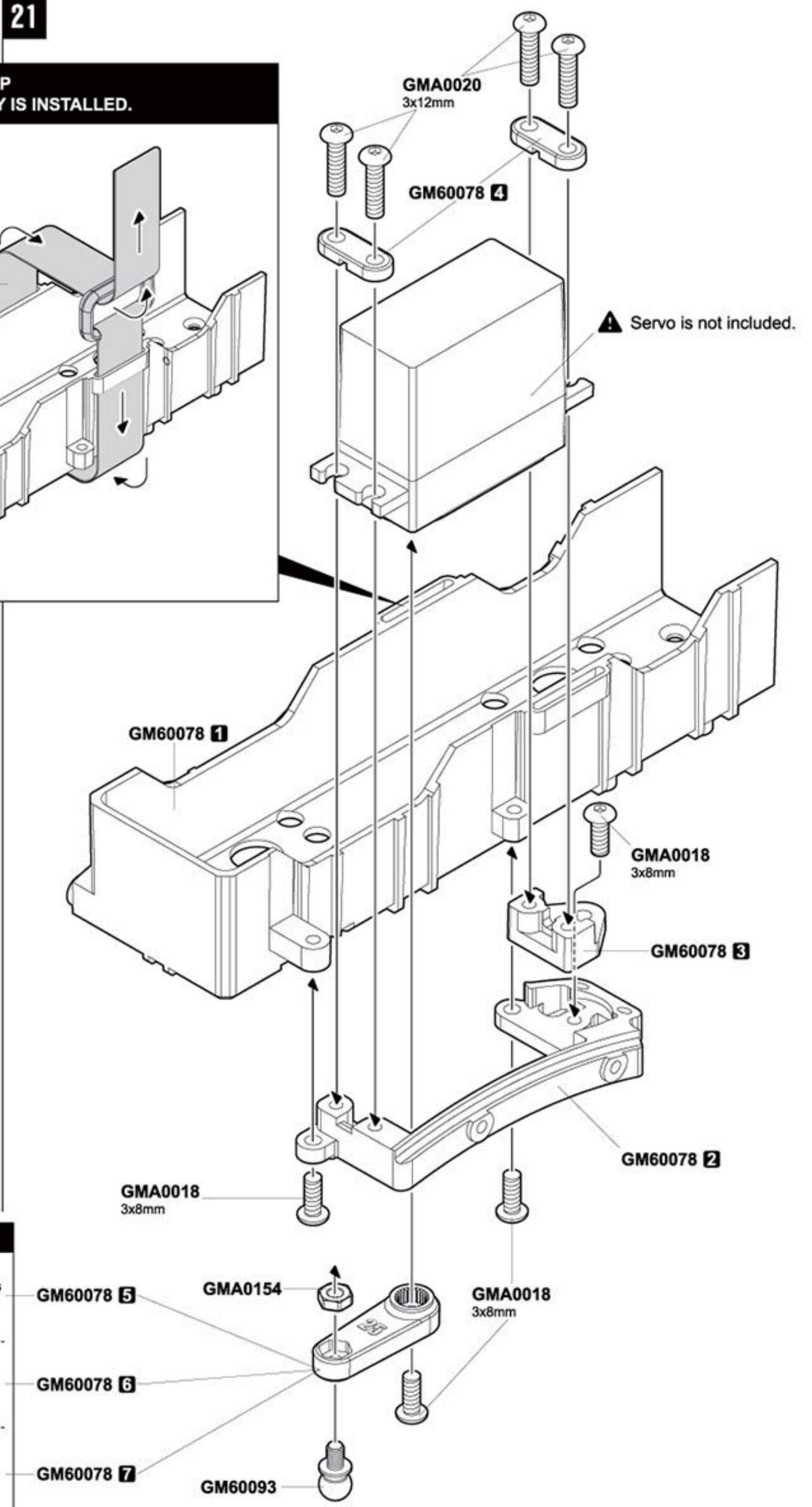
SERVO HORN

-  **23** SANWA
Airtronics
JR
KO
-  **24** Hitec
-  **25** Futaba



CHASSIS

22-A: REAR SHOCK HOOP

- 
GMA0017
 3x6mm
 Round head wrench bolt **x1**
- 
GMA0018
 3x8mm
 Round head wrench bolt **x4**
- 
GMA0019
 3X10mm
 Round head wrench bolt **x1**
- 
GMA0058
 3x10mm Flat head wrench bolt **x7**

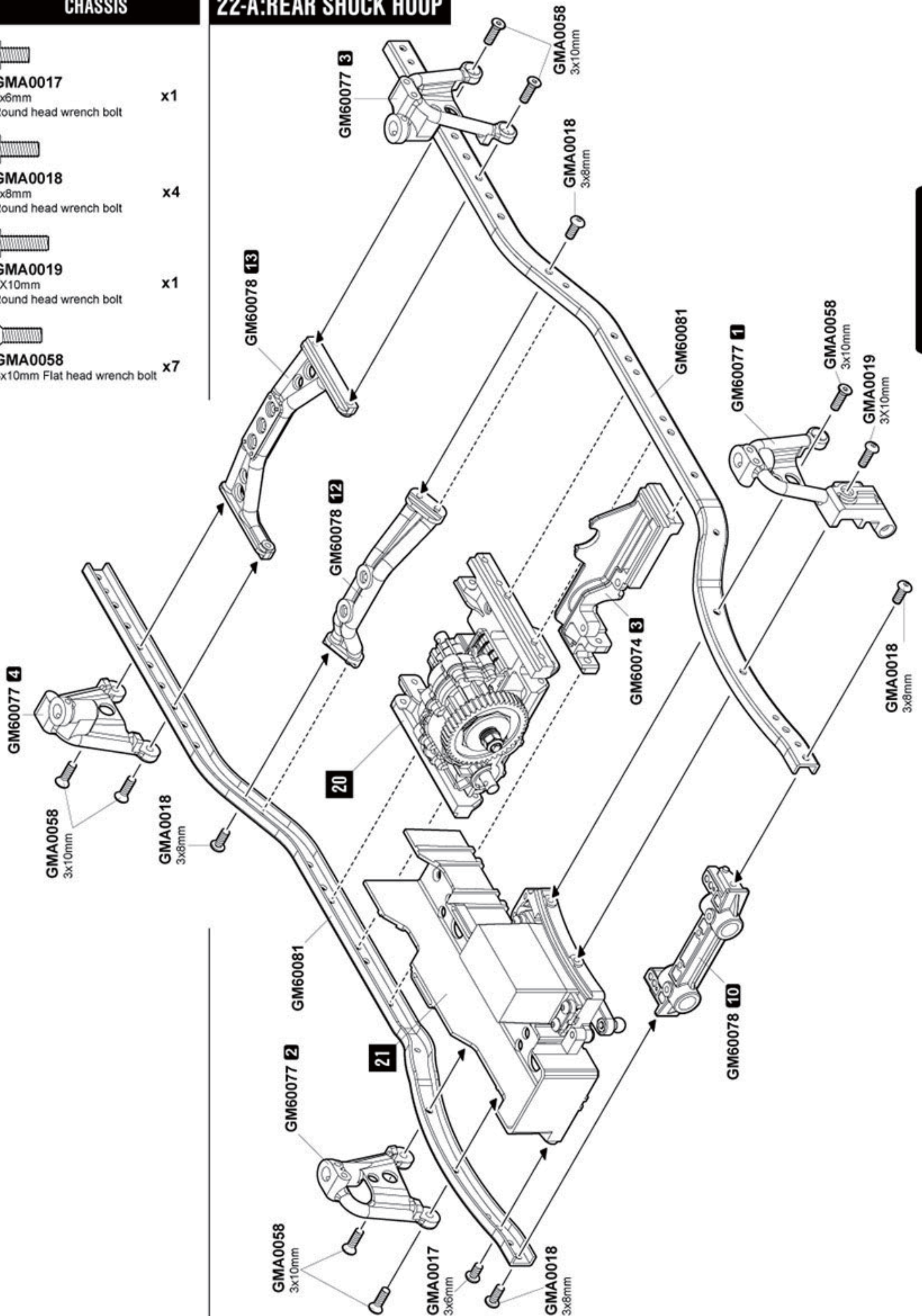

REAR SHOCK HOOP



GMA0017
3x6mm
Round head wrench bolt

x1

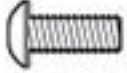

GMA0018
3x8mm
Round head wrench bolt

x11



GMA0019
3X10mm
Round head wrench bolt

x1

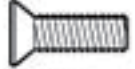

GMA0058
3x10mm Flat head wrench bolt

x3

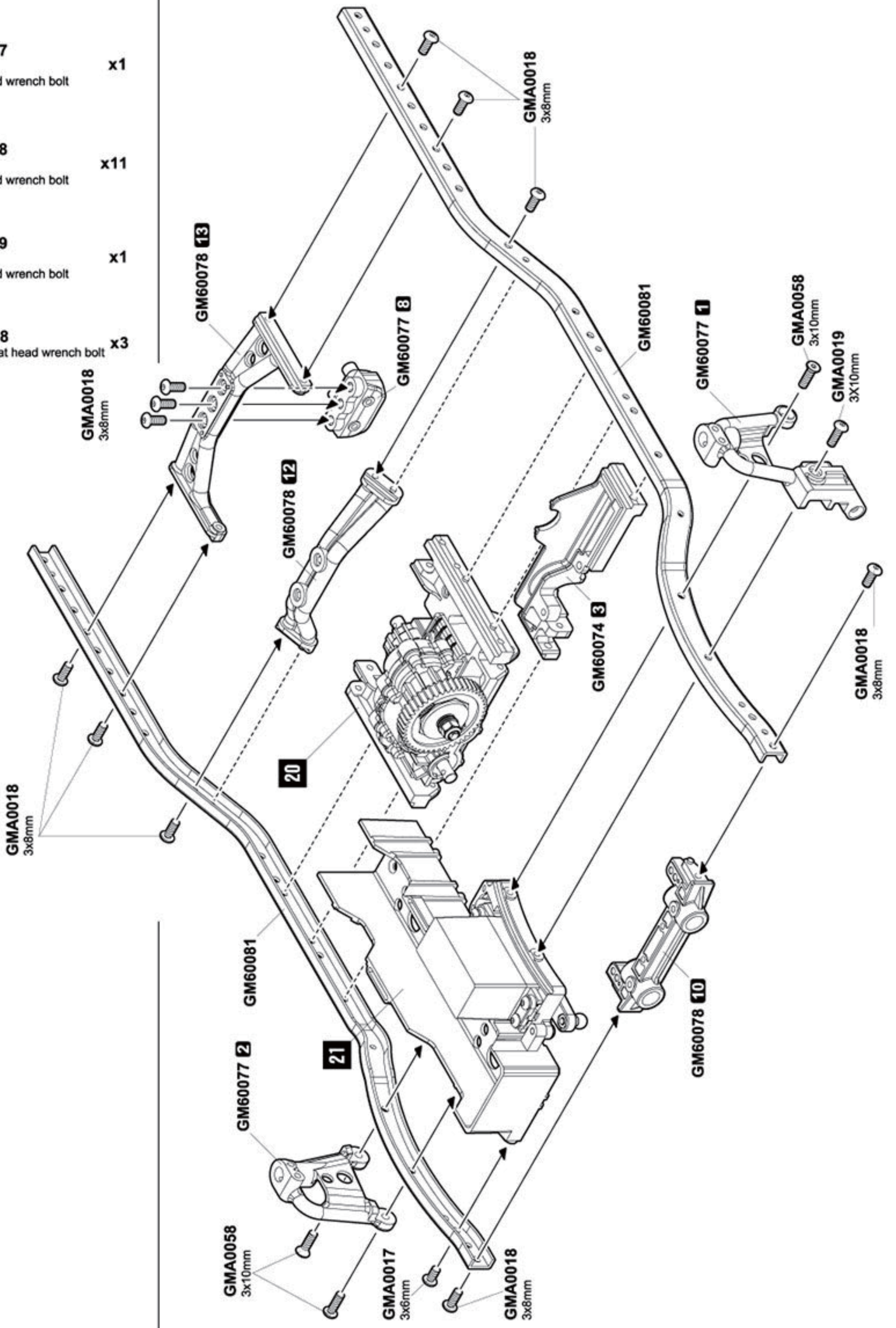





REAR SHOCK RELOCATION

CHASSIS

22-C:REAR CANTILEVER

⚠ TA PRO kit only.

-  **GMA0017**
3x6mm
Round head wrench bolt x1
-  **GMA0018**
3x8mm
Round head wrench bolt x6
-  **GMA0019**
3X10mm
Round head wrench bolt x1
-  **GMA0058**
3x10mm Flat head wrench bolt x3

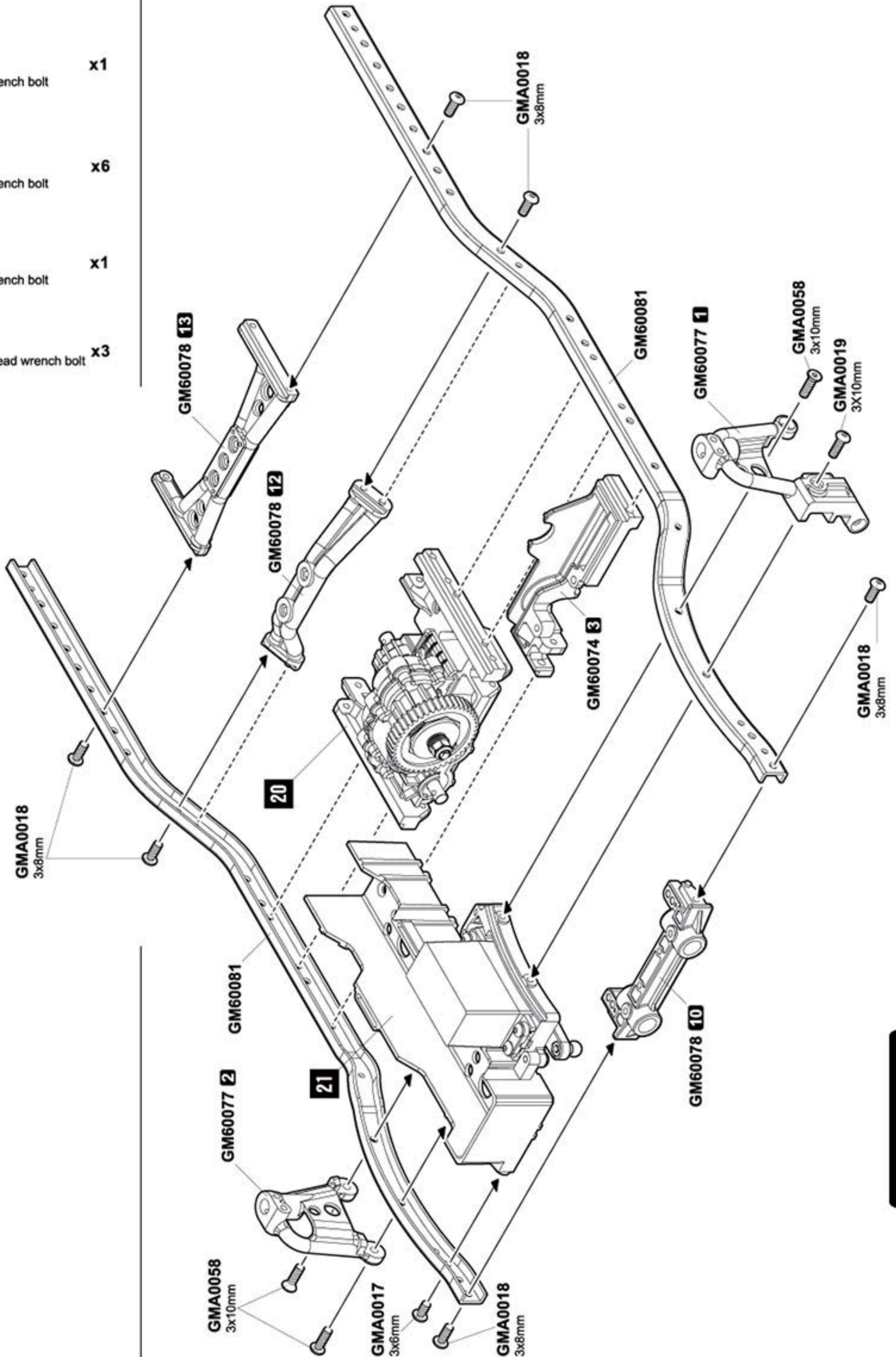

REAR CANTILEVER



GMA0017
3x6mm
Round head wrench bolt

x4

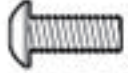

GMA0018
3x8mm
Round head wrench bolt

x2



GMA0021
3x15mm
Round head wrench bolt

x2



GMA0057
3x8mm Flat head wrench bolt

x1

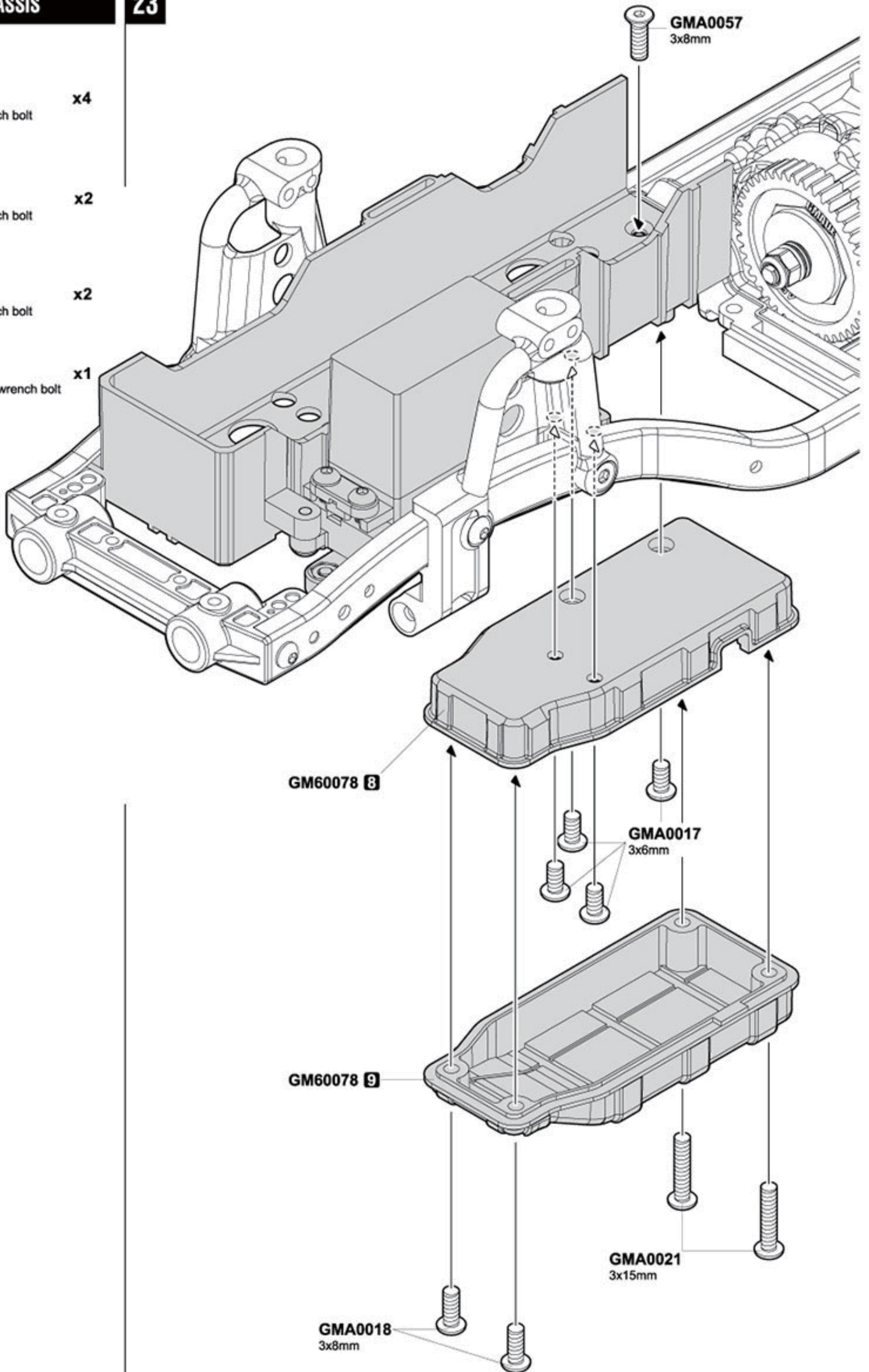

GMA0057
3x8mm

GM60078 8

GMA0017
3x6mm

GM60078 9

GMA0021
3x15mm

GMA0018
3x8mm

FRONT LOWER LINK

24



GM60090
Lower link M4x6.8x80mm x2

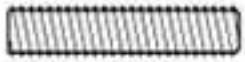

GMA0145
4x20mm Socket set screw x4

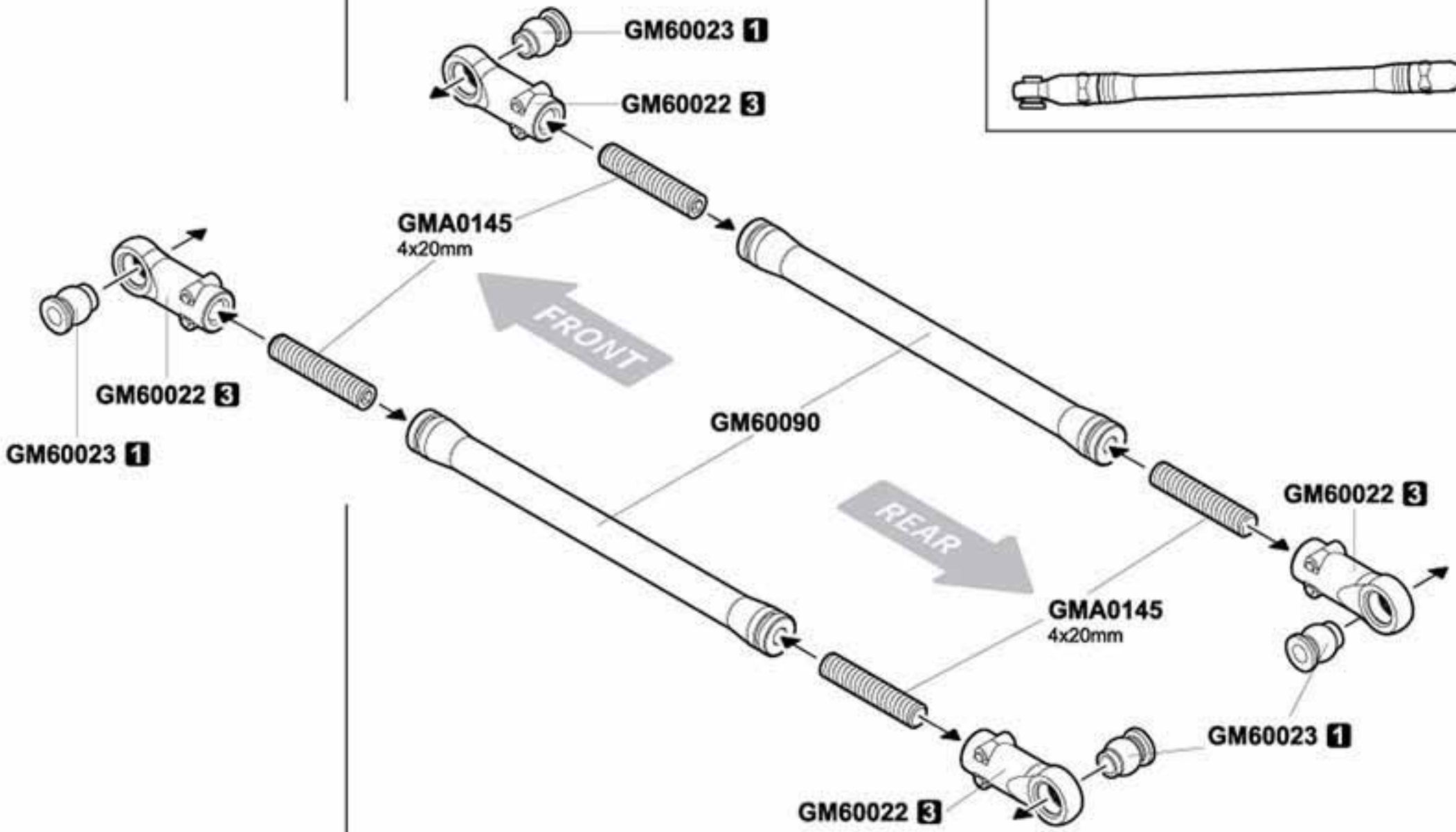

FRONT LOWER LINK TOP VIEW

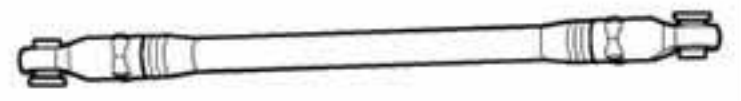

FRONT UPPER LINK

25

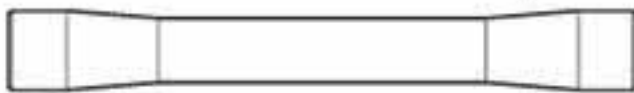

GM60089
Upper link M4x6.8x55mm x1



GMA0145
4x20mm Socket set screw x2

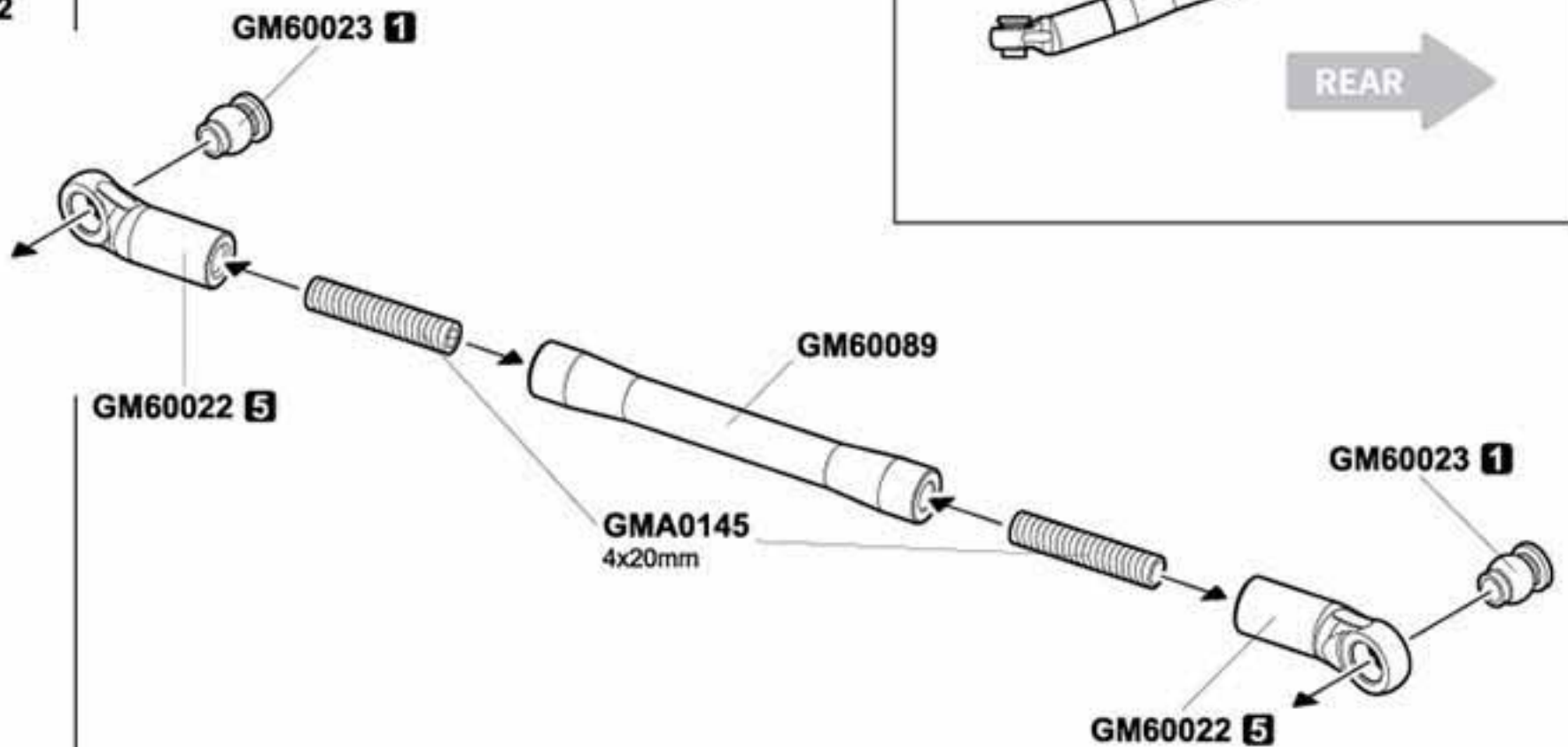

FRONT UPPER LINK TOP VIEW

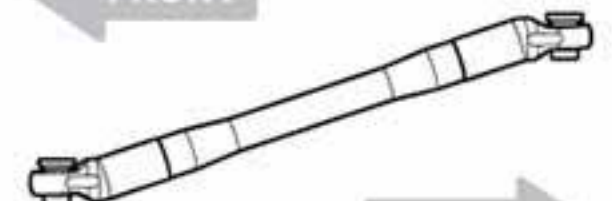

REAR LOWER LINK

26

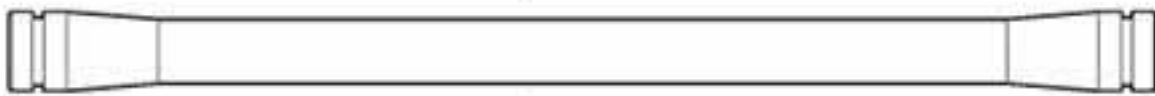

GM60092
Lower link M4x6.8x100mm x2

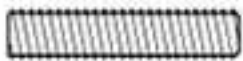

GMA0145
4x20mm Socket set screw x4

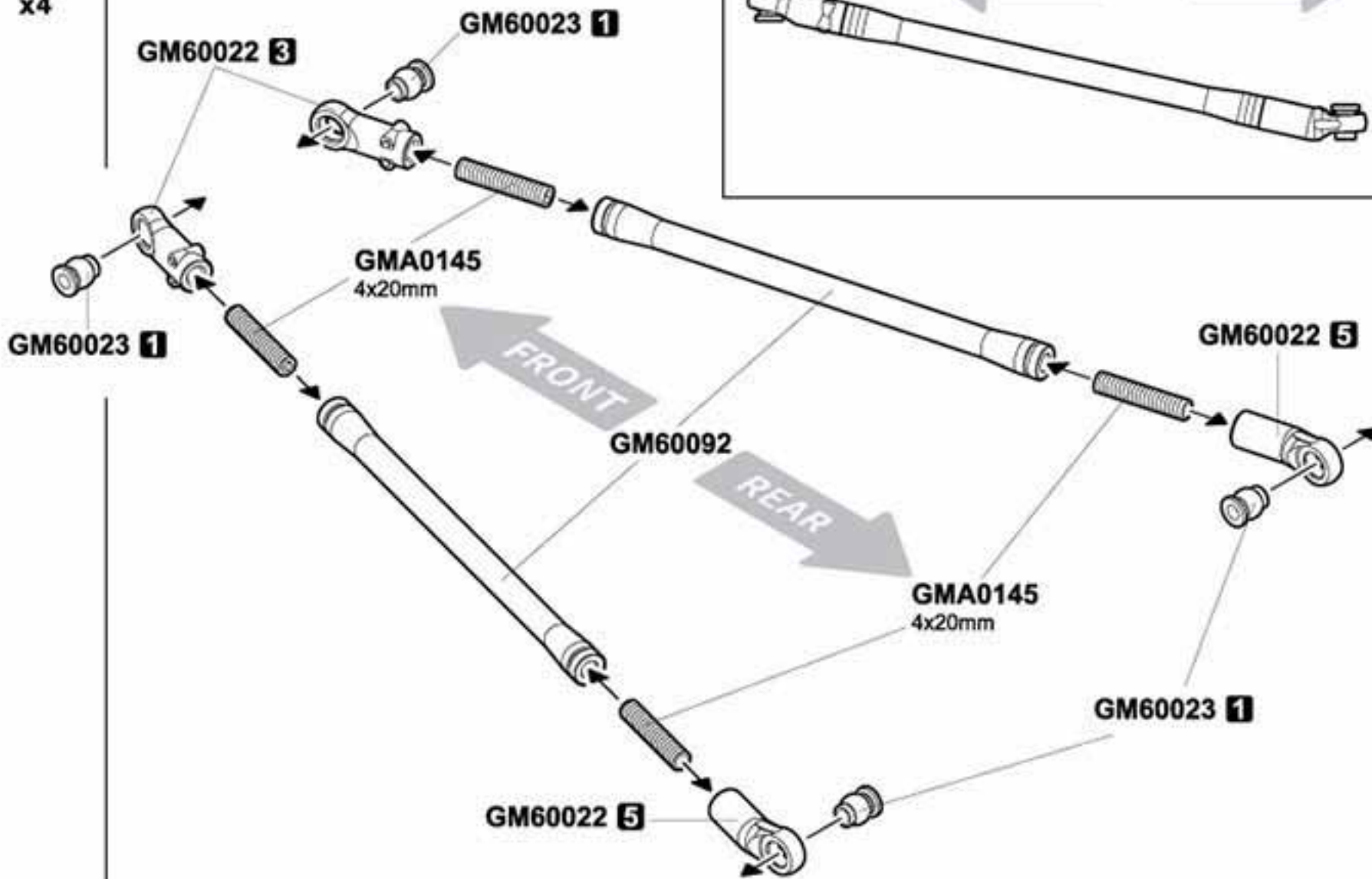

REAR LOWER LINK TOP VIEW

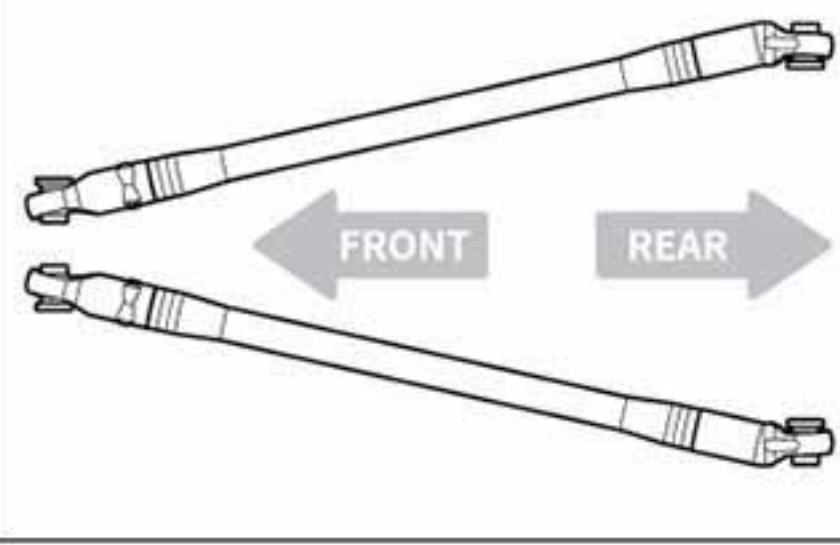

REAR UPPER LINK

27

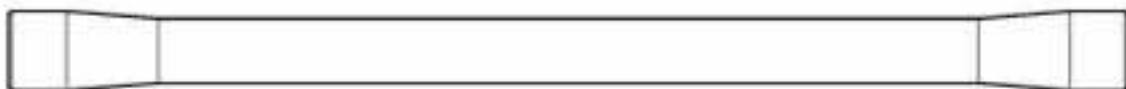

GM60091
Upper link M4x6.8x98mm x2



GMA0145
4x20mm Socket set screw x4

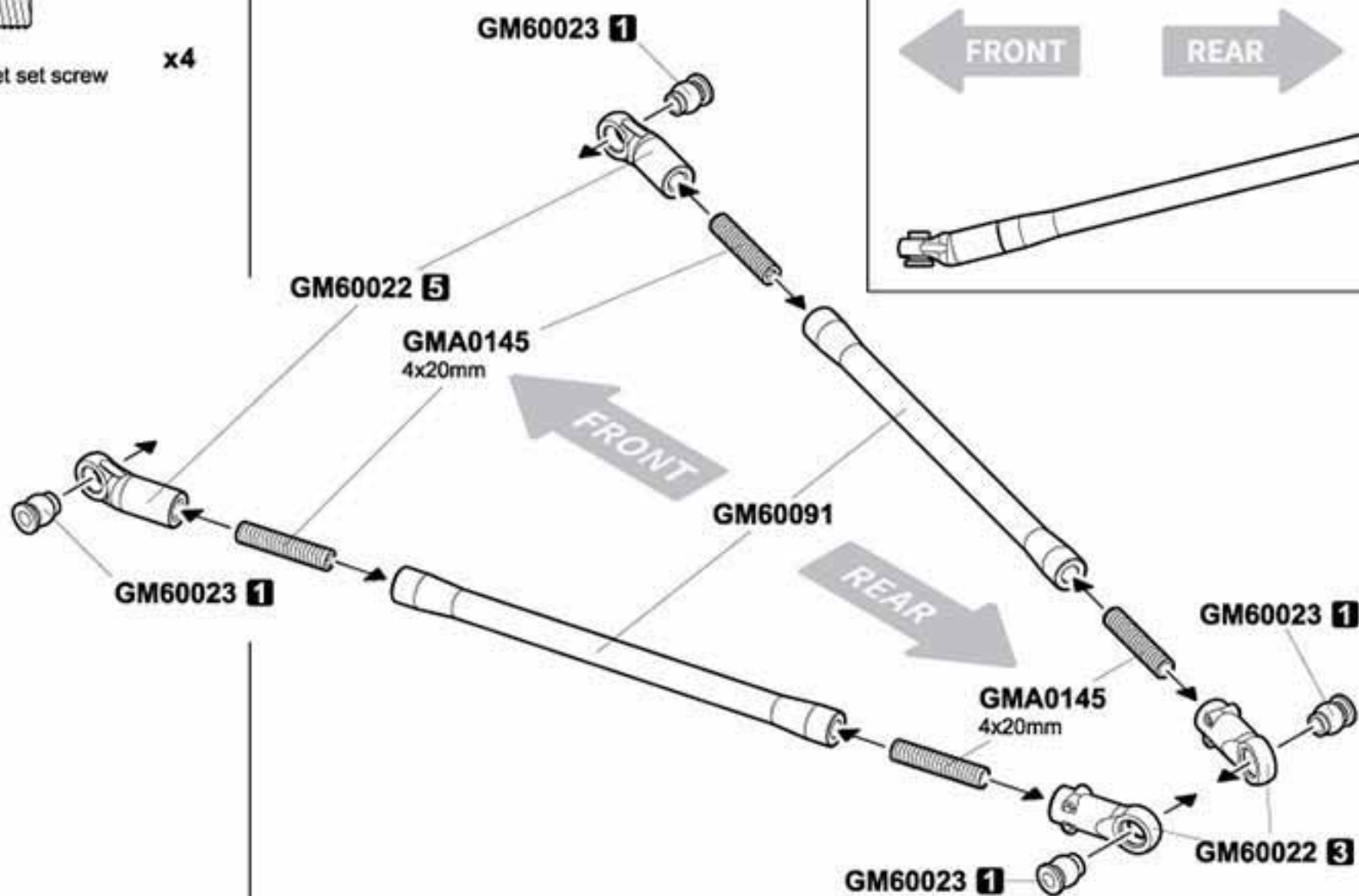

REAR UPPER LINK TOP VIEW

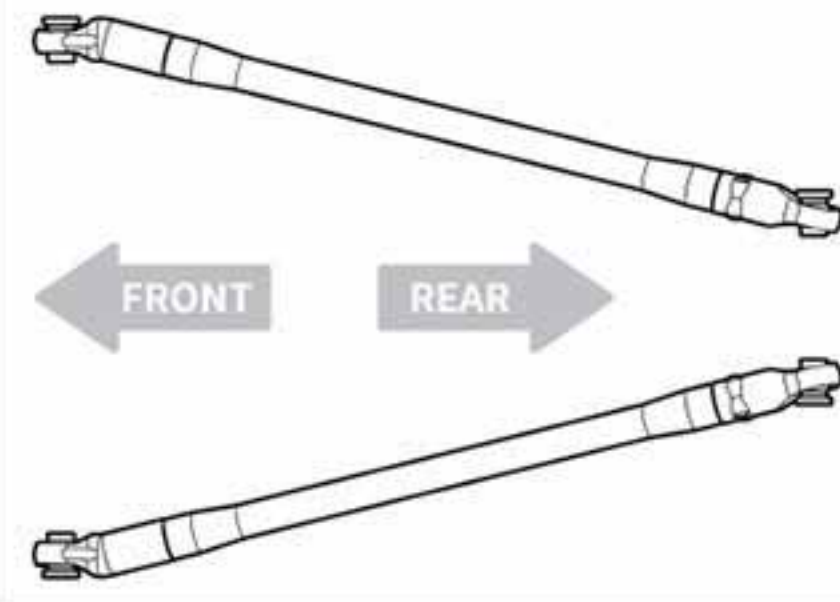

 **GMA0018**
3x8mm
Round head wrench bolt

x1

 **GMA0019**
3x10mm
Round head wrench bolt

x4

 **GMA0172**
3x18mm
Round head wrench bolt

x3

 **GMA0133**
3x15mm Socket set screw

x4

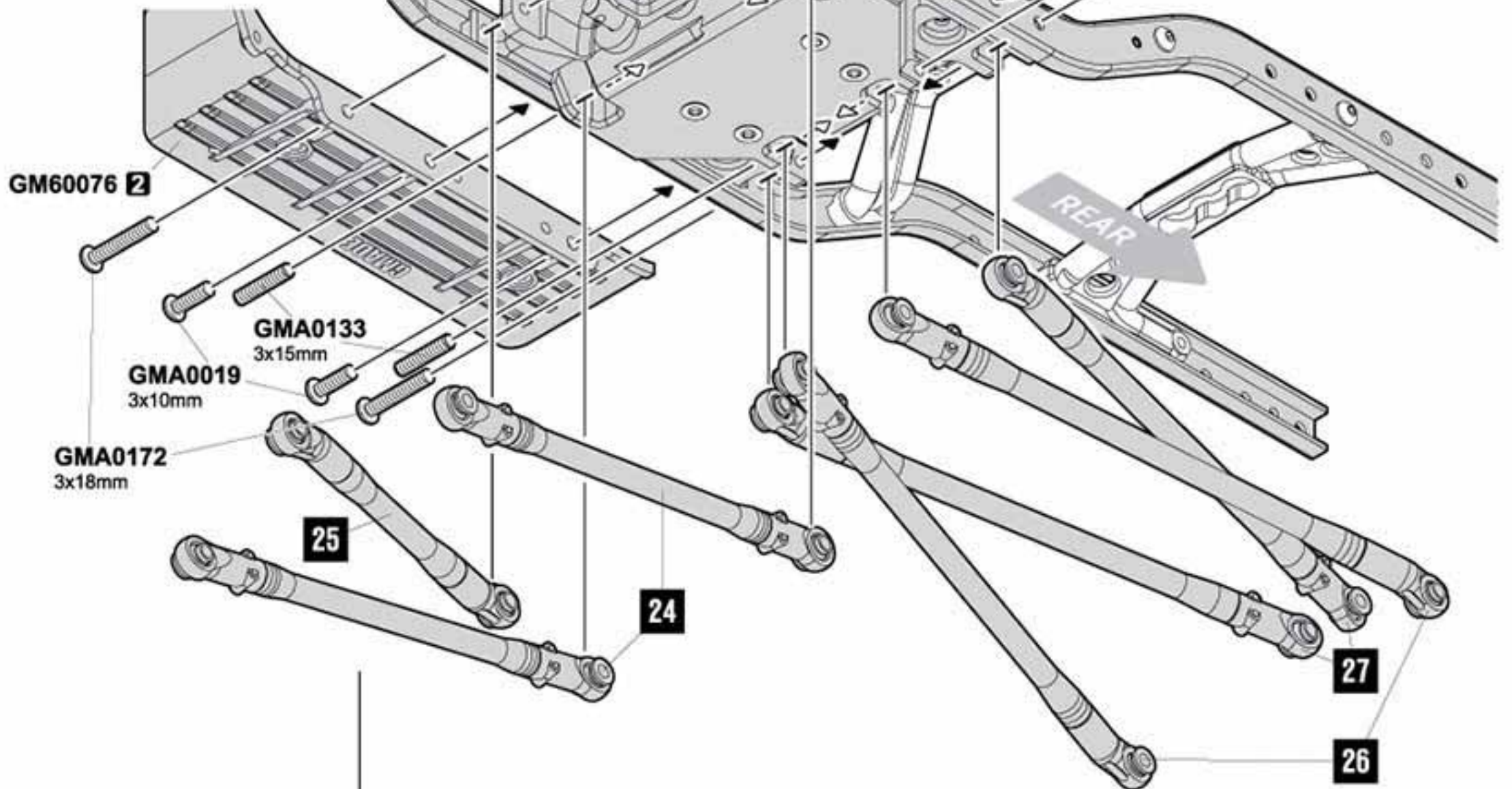

CHASSIS BOTTOM VIEW

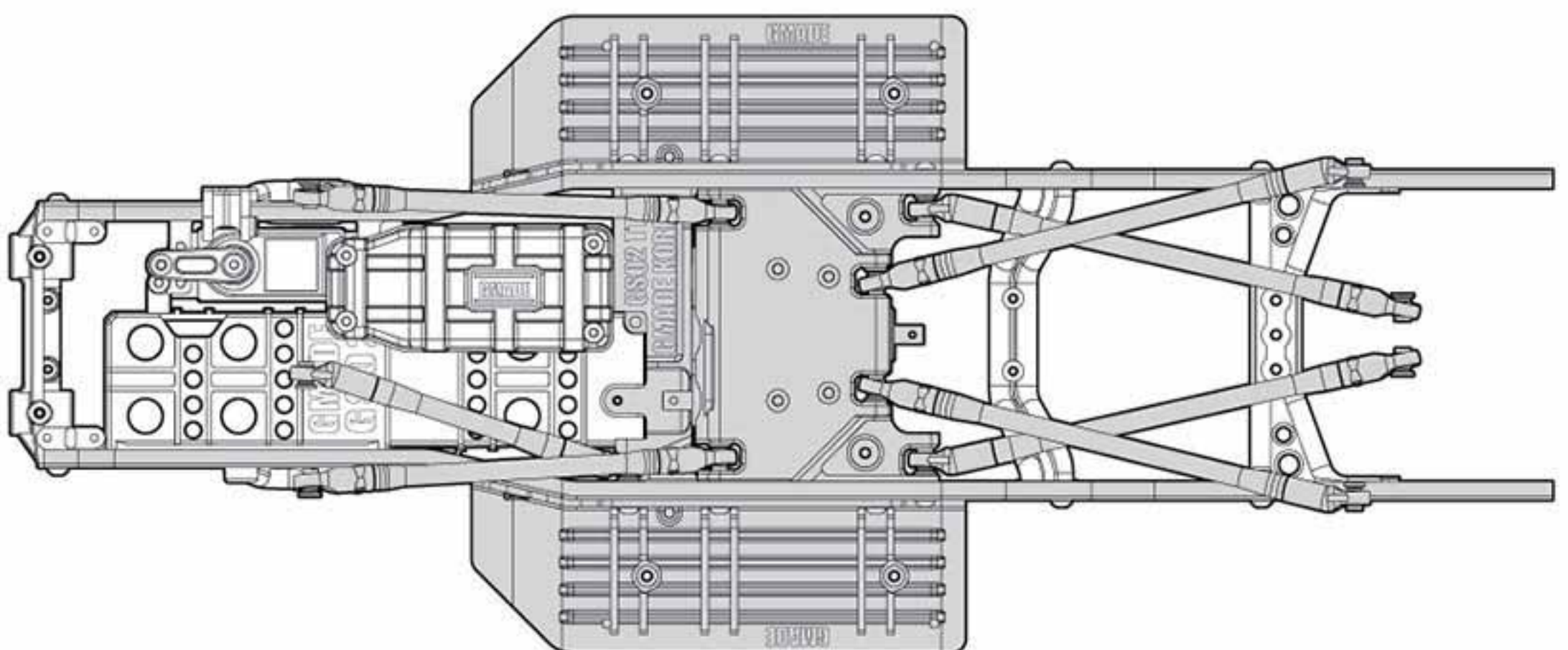

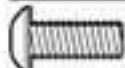

GMA0018
3x8mm
Round head wrench bolt x2



GMA0020
3x12mm
Round head wrench bolt x3



GMA0126
3x3mm Socket set screw x1



GMA0127
3x4mm Socket set screw x1



GM60072
32P 13T pinion gear x1

Gear ratio

Pinion	LO	HI (Option)
9T	52.77	25.00
10T	47.50	22.50
11T	43.18	20.45
12T	39.58	18.75
Stock 13T	36.53	17.30
14T	33.92	16.07
15T	31.66	15.00

⚠ Motor is not included.

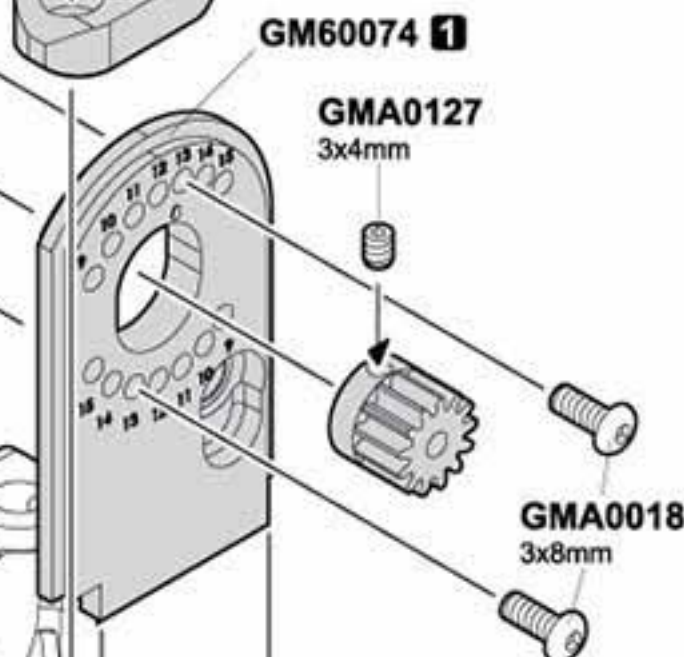
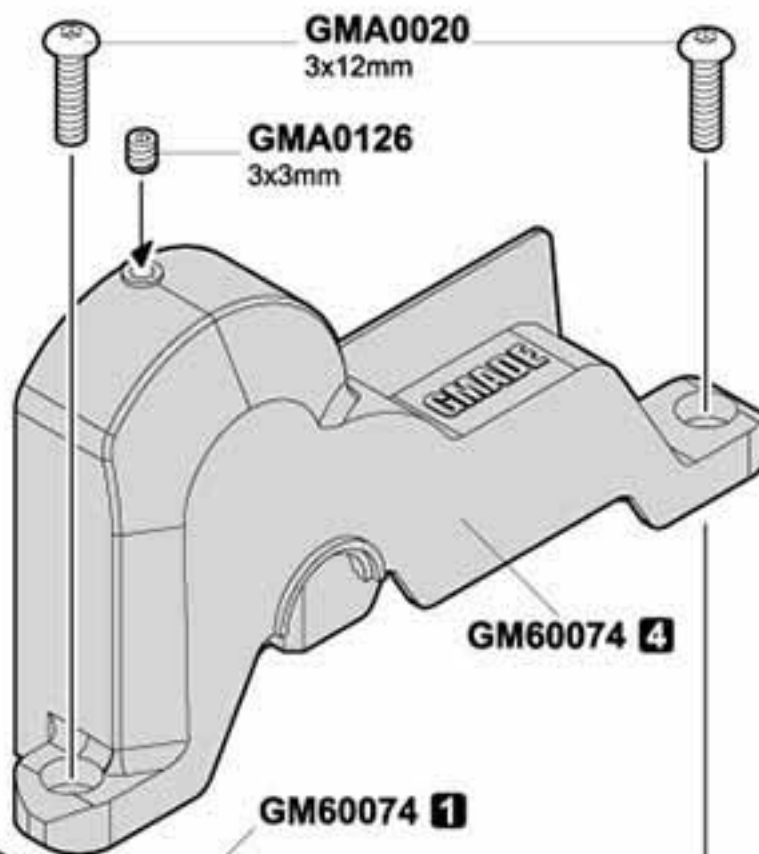
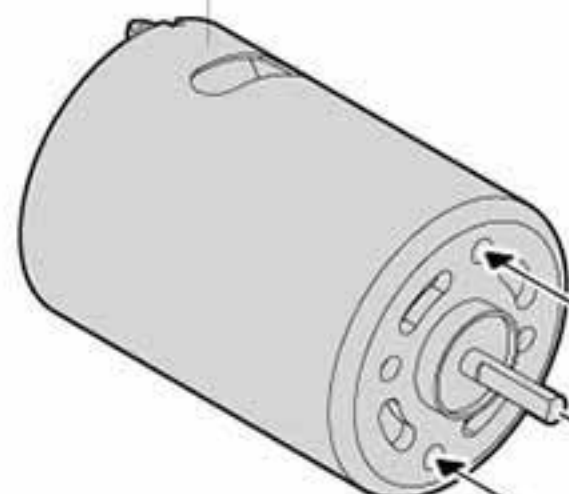



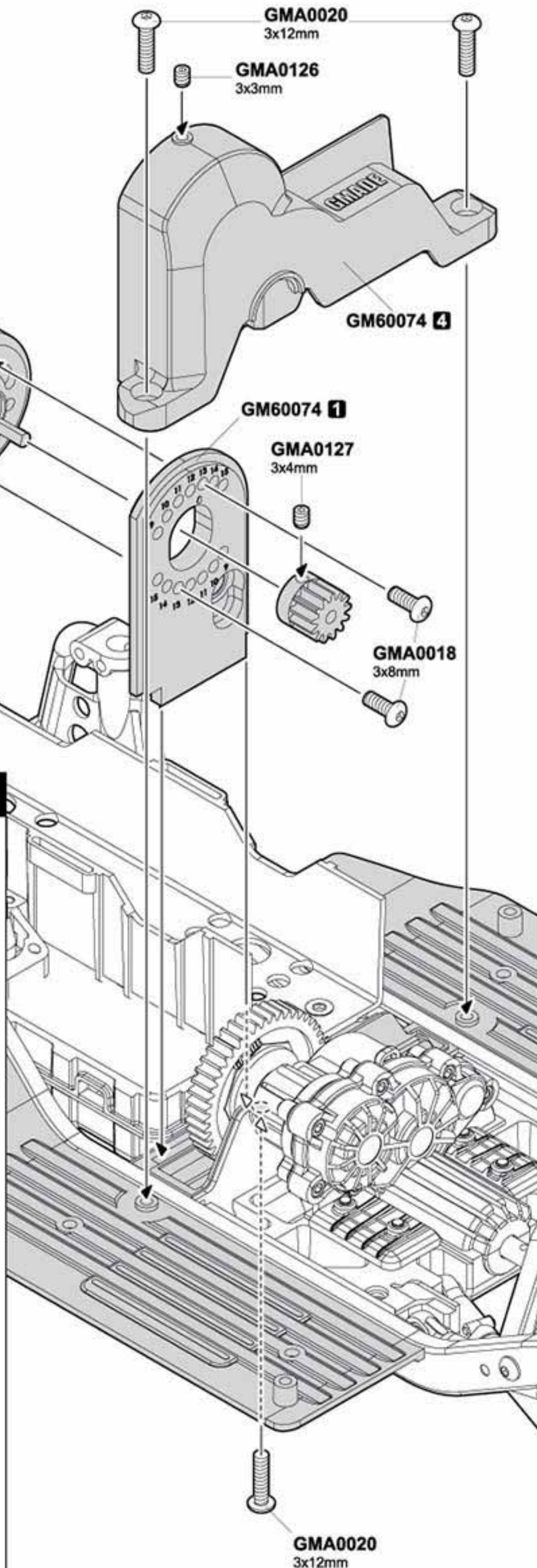
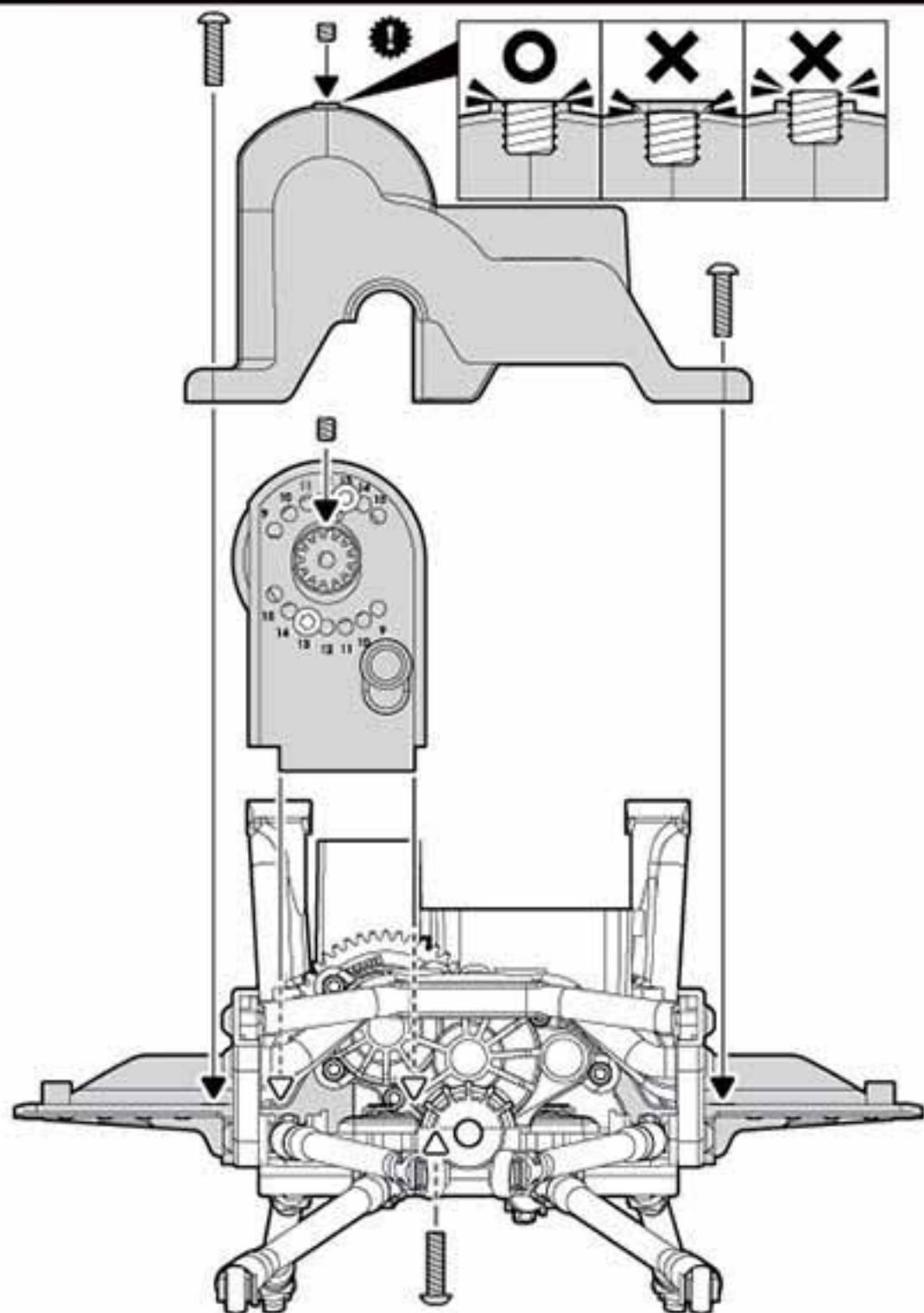

⚠ CHASSIS REAR VIEW



FRONT UNIVERSAL SHAFT

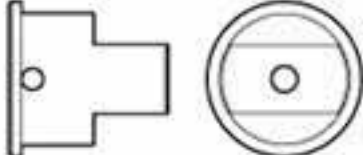

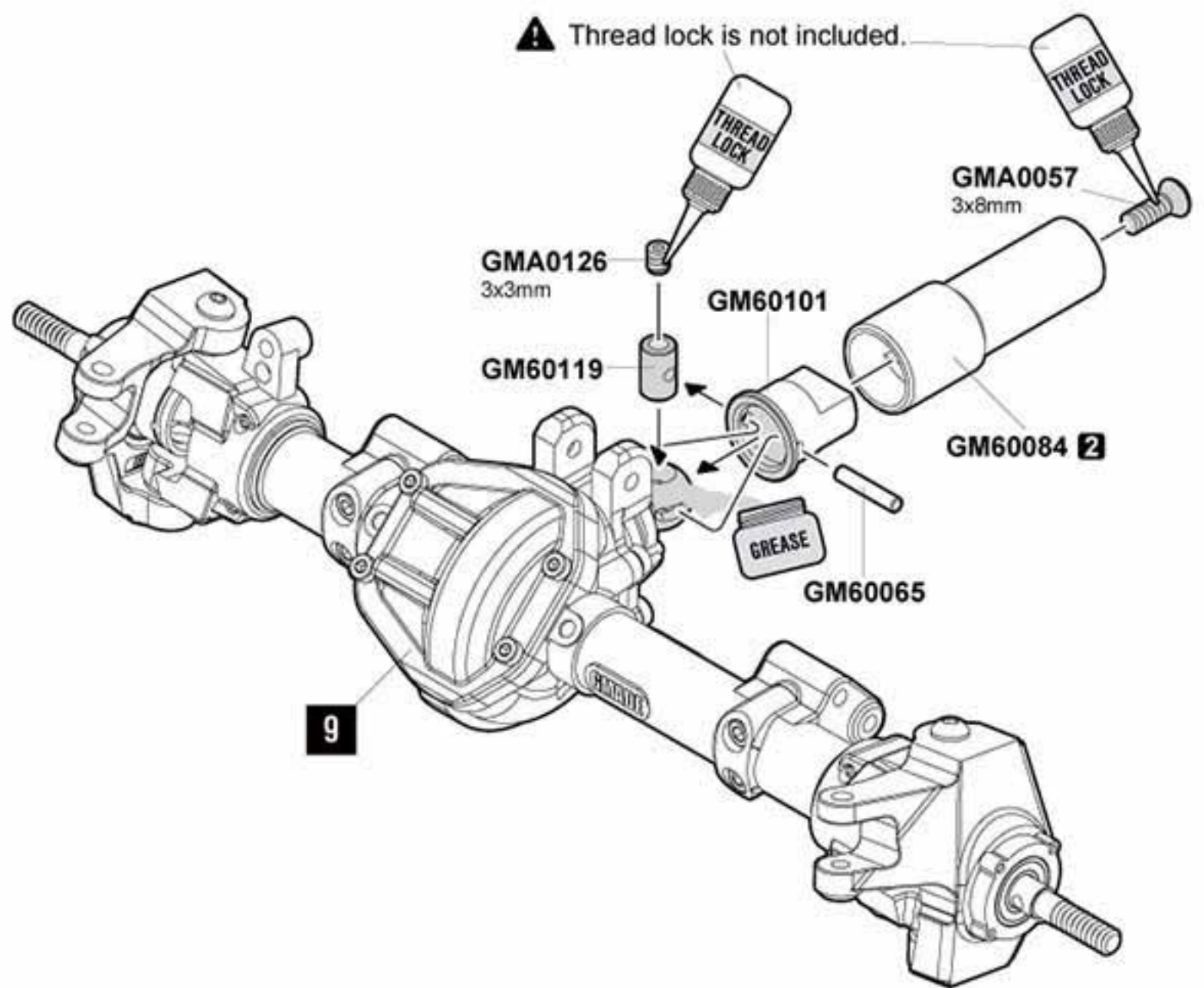

30 ⚠️ TS kit only.

-  **GMA0126** x1
3x3mm Socket set screw
-  **GMA0057** x1
3x8mm Flat head wrench bolt
-  **GM60101** x1
Universal joint cup
-  **GM60119** x1
Universal joint drive coupler
-  **GM60065** x1
Pin 2x11.4mm





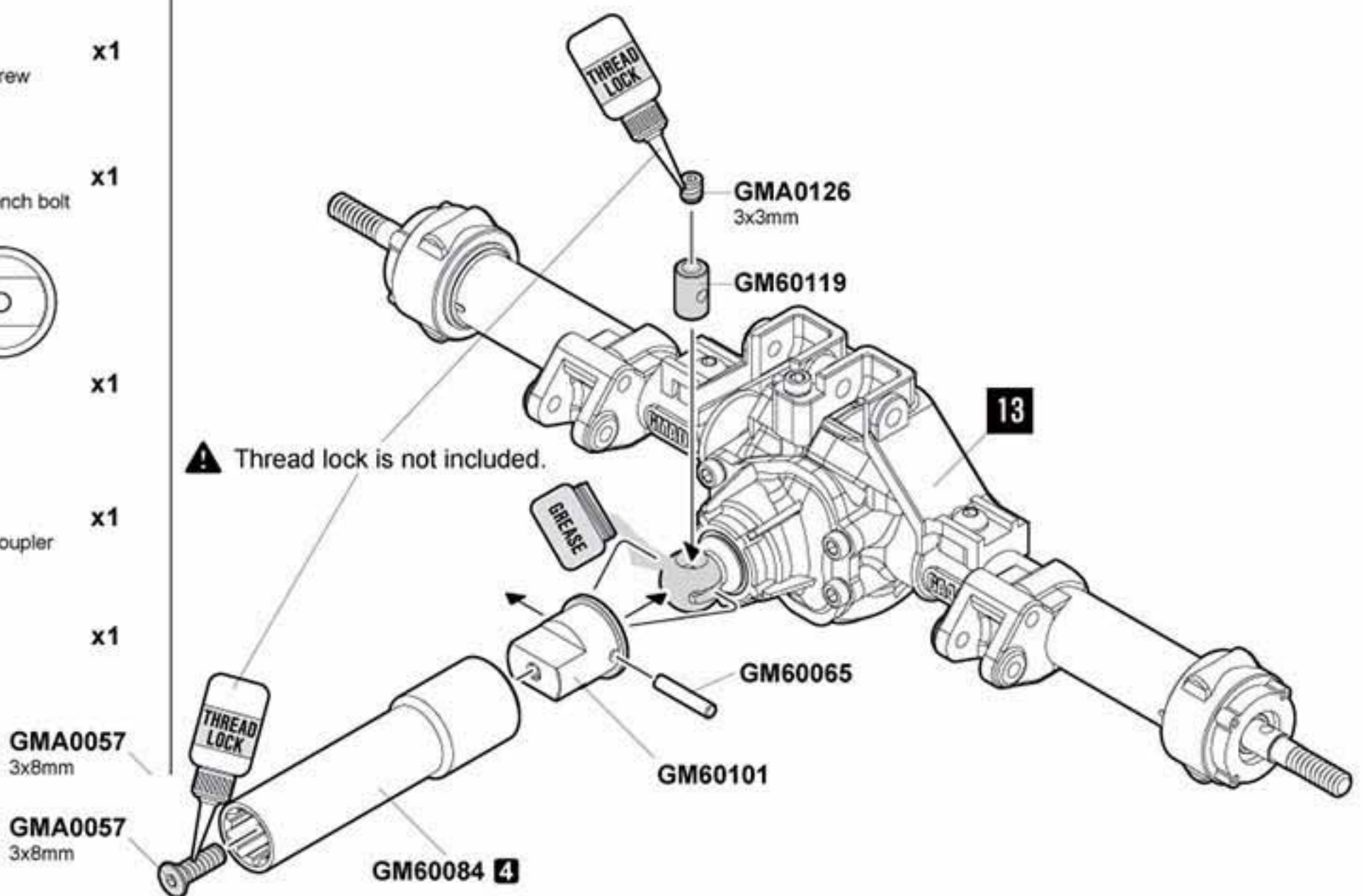

REAR UNIVERSAL SHAFT

31 ⚠️ TS kit only.

-  **GMA0126** x1
3x3mm Socket set screw
-  **GMA0057** x1
3x8mm Flat head wrench bolt
-  **GM60101** x1
Universal joint cup
-  **GM60119** x1
Universal joint drive coupler
-  **GM60065** x1
Pin 2x11.4mm

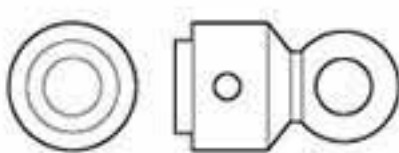
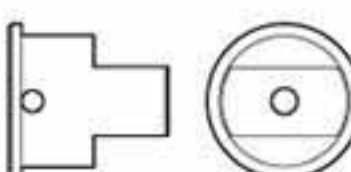
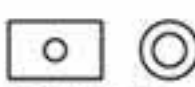

UNIVERSAL SHAFT

-  **GMA0126** x2
3x3mm Socket set screw
-  **GMA0057** x2
3x8mm Flat head wrench bolt
-  **GM60101** x2
Universal joint
-  **GM60101** x2
Universal joint cup
-  **GM60119** x2
Universal joint drive coupler
-  **GM60065** x2
Pin 2x11.4mm
-  **GM60103** x2
3x10mm Screw pin

32



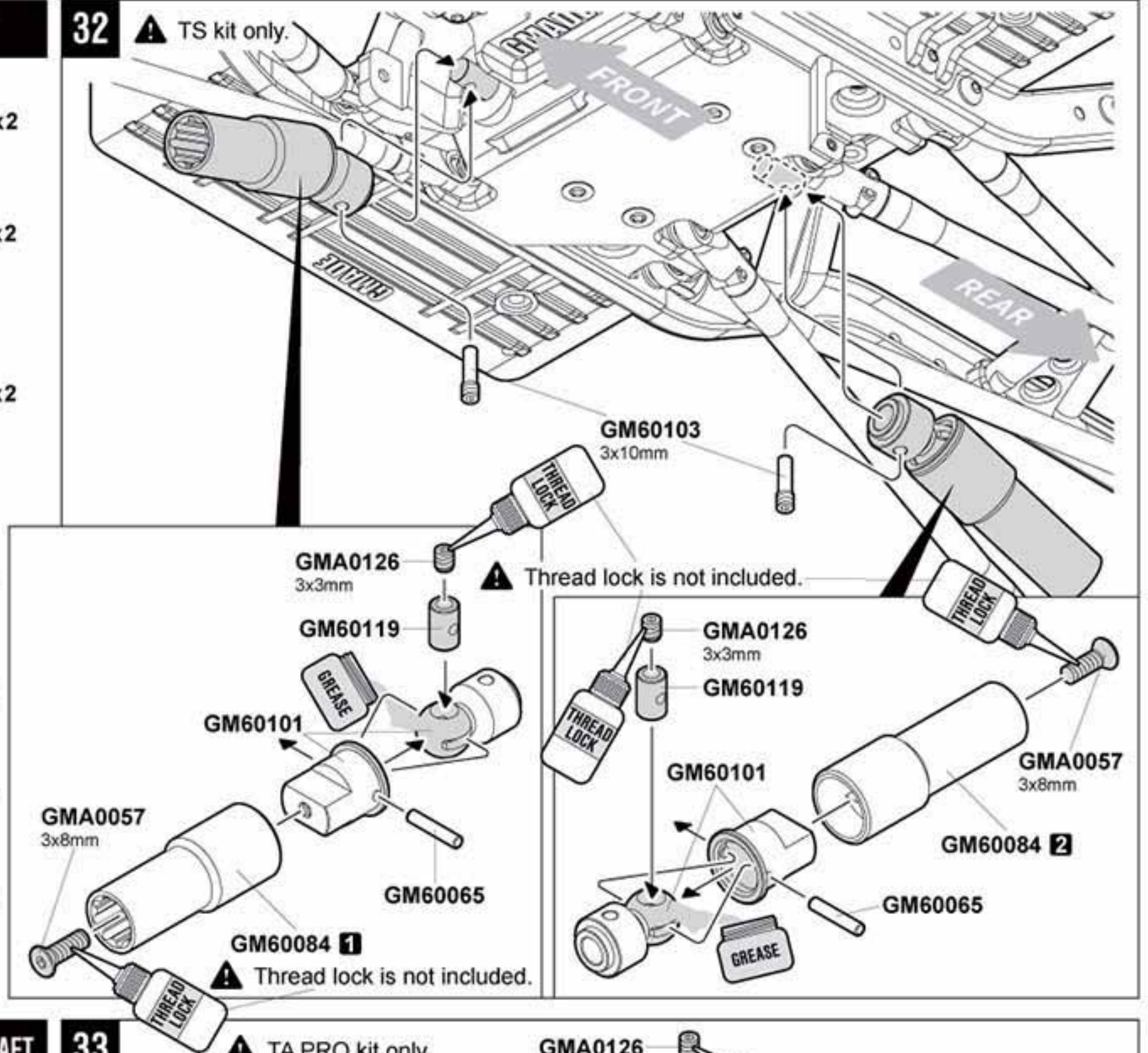

⚠ TS kit only.

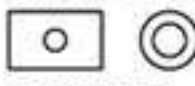

HARDENED UNIVERSAL SHAFT

33



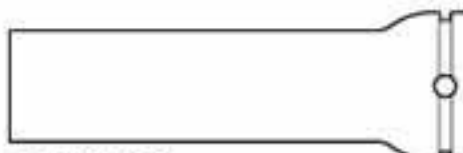
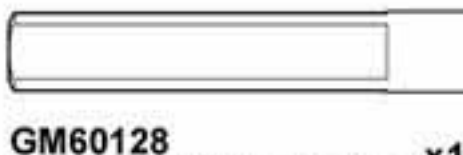

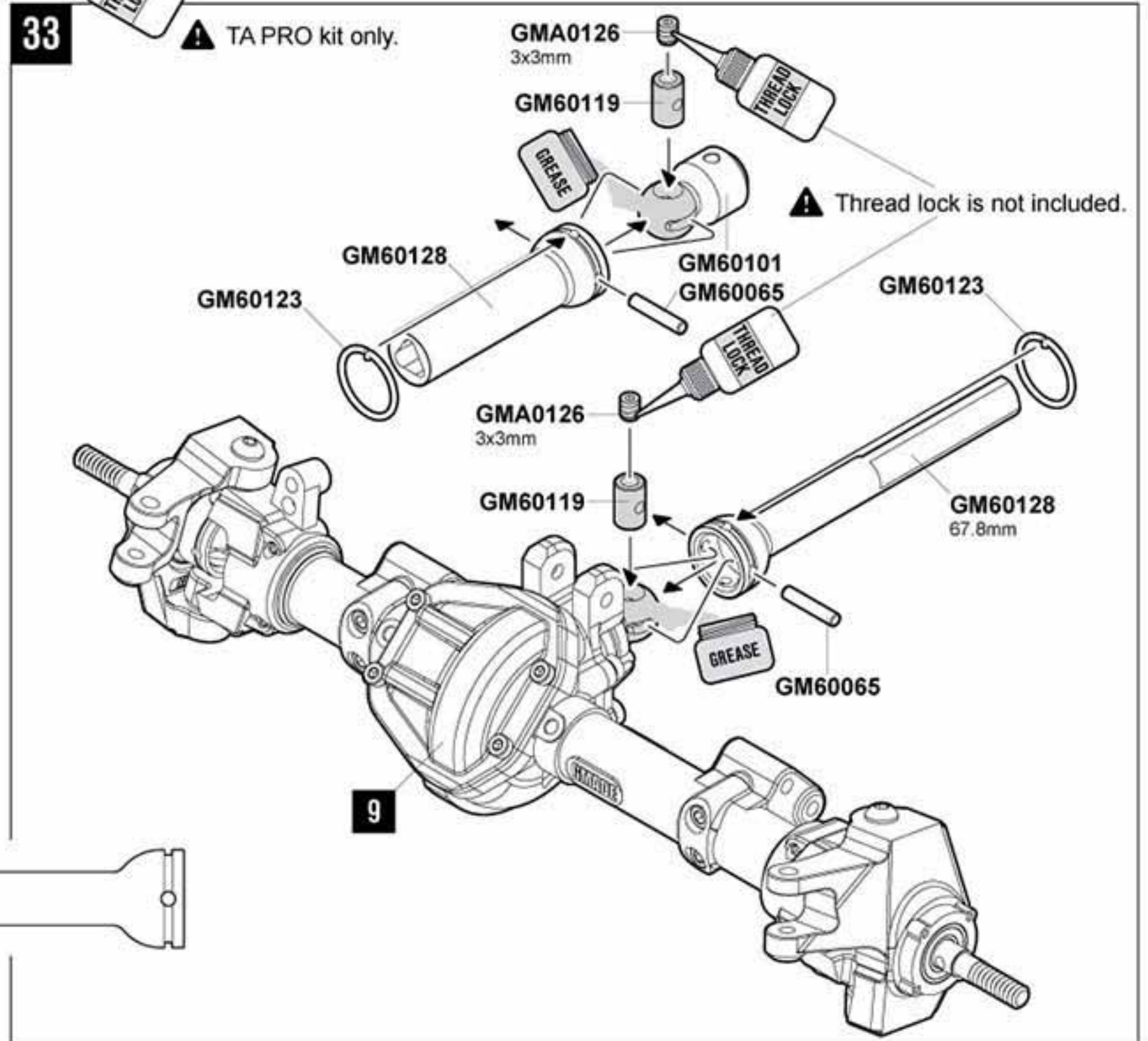
⚠ TA PRO kit only.

-  **GMA0126** x2
3x3mm Socket set screw
-  **GM60119** x2
Universal joint drive coupler
-  **GM60065** x2
Pin 2x11.4mm
-  **GM60101** x1
Universal joint
-  **GM60123** x2
12.8x0.7mm Pin retainer
-  **GM60128** x1
Universal shaft 40mm (Female)
-  **GM60128** x1
Universal shaft 67.8mm (Male)

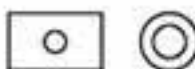

HARDENED UNIVERSAL SHAFT

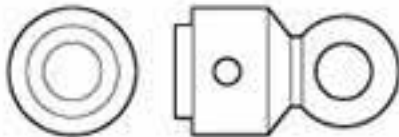
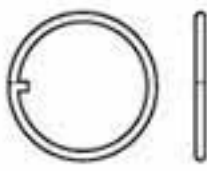
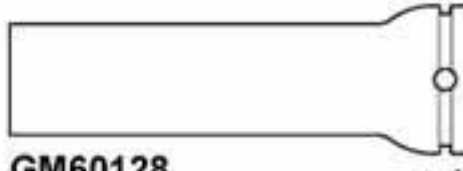
34 ⚠ TA PRO kit only.

-  **GMA0126**
3x3mm Socket set screw x2
-  **GM60119**
Universal joint drive coupler x2
-  **GM60065**
Pin 2x11.4mm x2
-  **GM60101**
Universal joint x1
-  **GM60123**
12.8x0.7mm Pin retainer x2
-  **GM60128**
Universal shaft 40mm(Female) x1
-  **GM60128**
Universal shaft 89.3mm (Male) x1

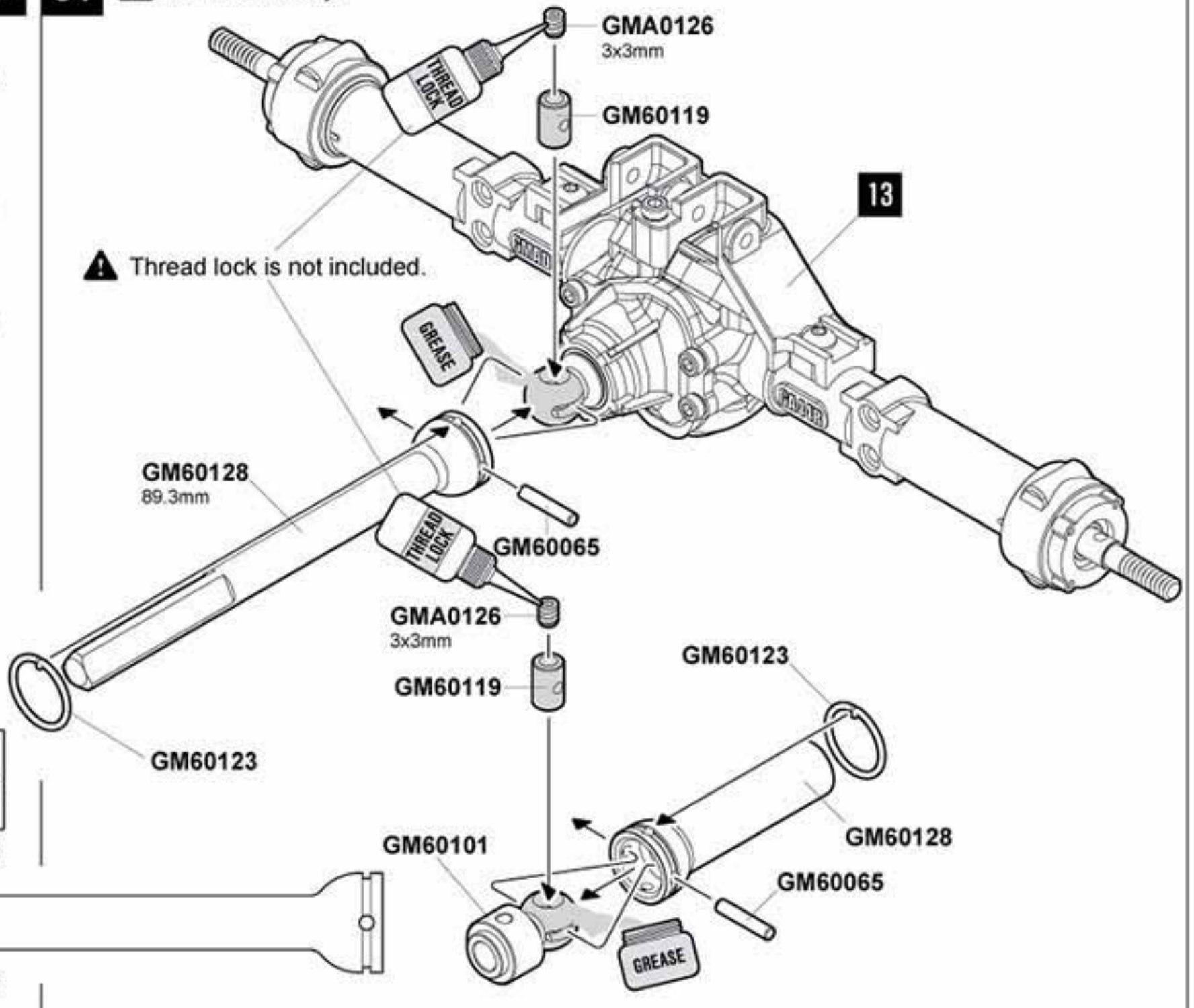

FRONT AXLE

35

-  **GMA0021**
3x15mm Round head wrench bolt x3

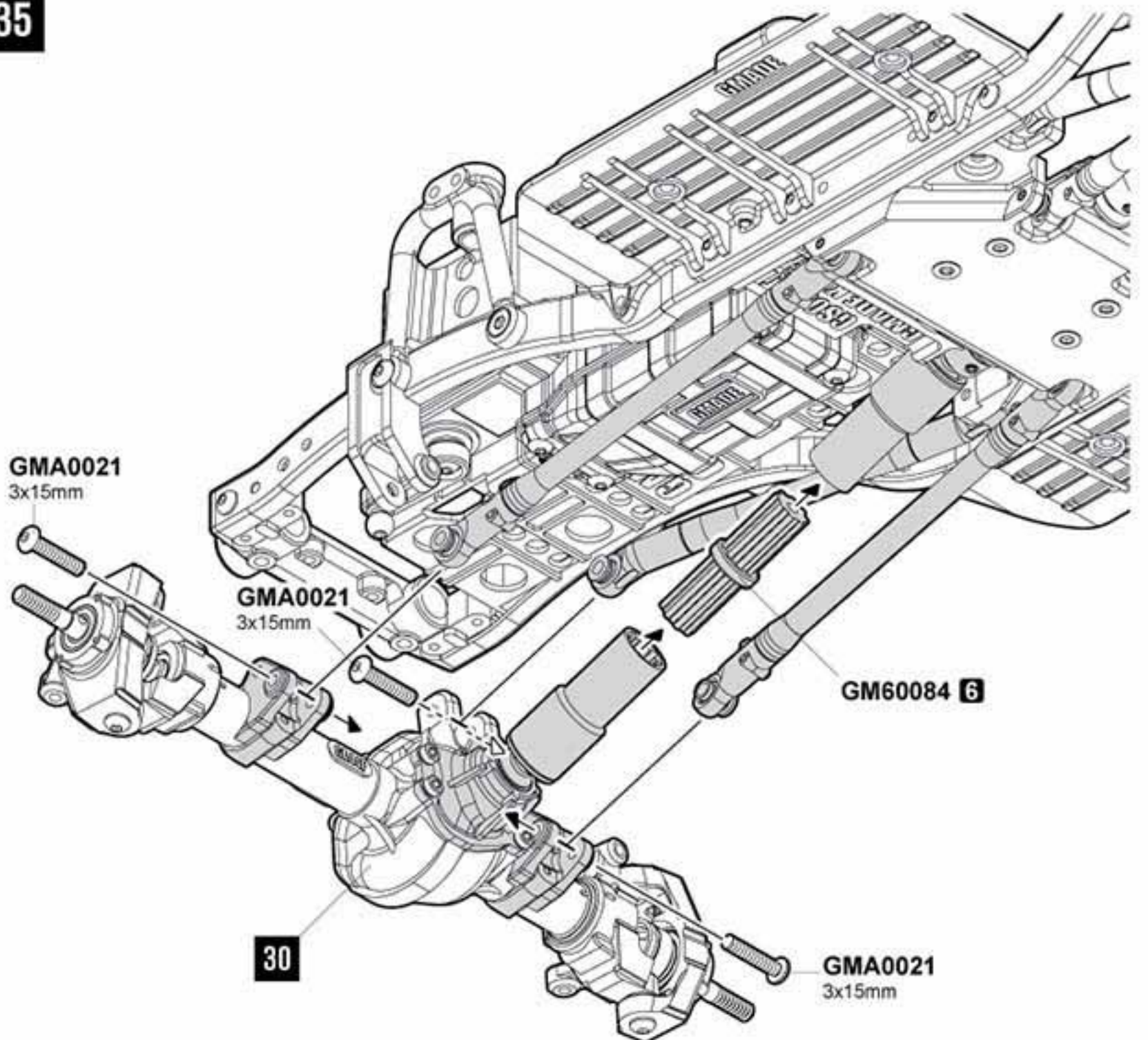

SHOCK ABSORBER



GMA0212
7x1 O-ring x4

GMA0160
2mm E-ring x4

GMA0169
P3 O-ring x8

GM0020075
Shock shaft 3.5x46.4mm x2

GM60096
Shock shaft 3.5x33.9mm x2

GM60094
SD 90mm shock body x2

GM60095
SD 67mm shock body x2

SHOCK ABSORBER TYPES



Required for assembly



SD 90mm shock x 4



SD 90mm shock x 2
SD 67mm shock x 2

⚠ TA PRO kit only.



SD 90mm shock x 2
SD 67mm shock x 2

⚠ TA PRO kit only.

36 ⚠ MAKE X 4

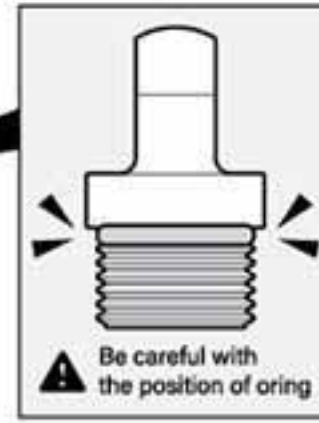
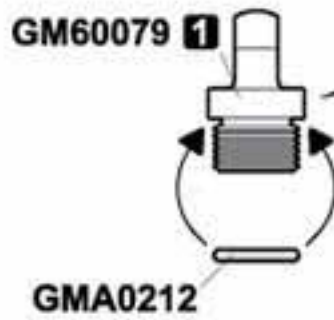

37 ⚠ SD 90mm shock

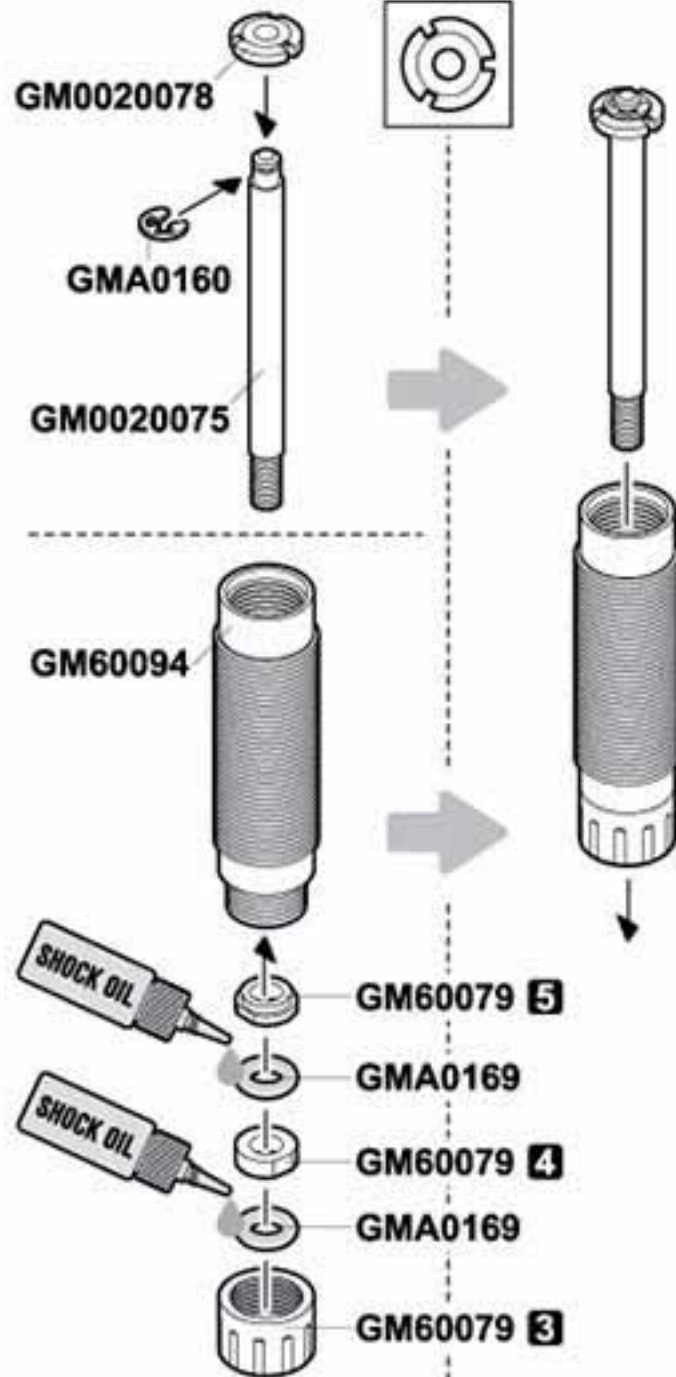

38 ⚠ SD 67mm shock

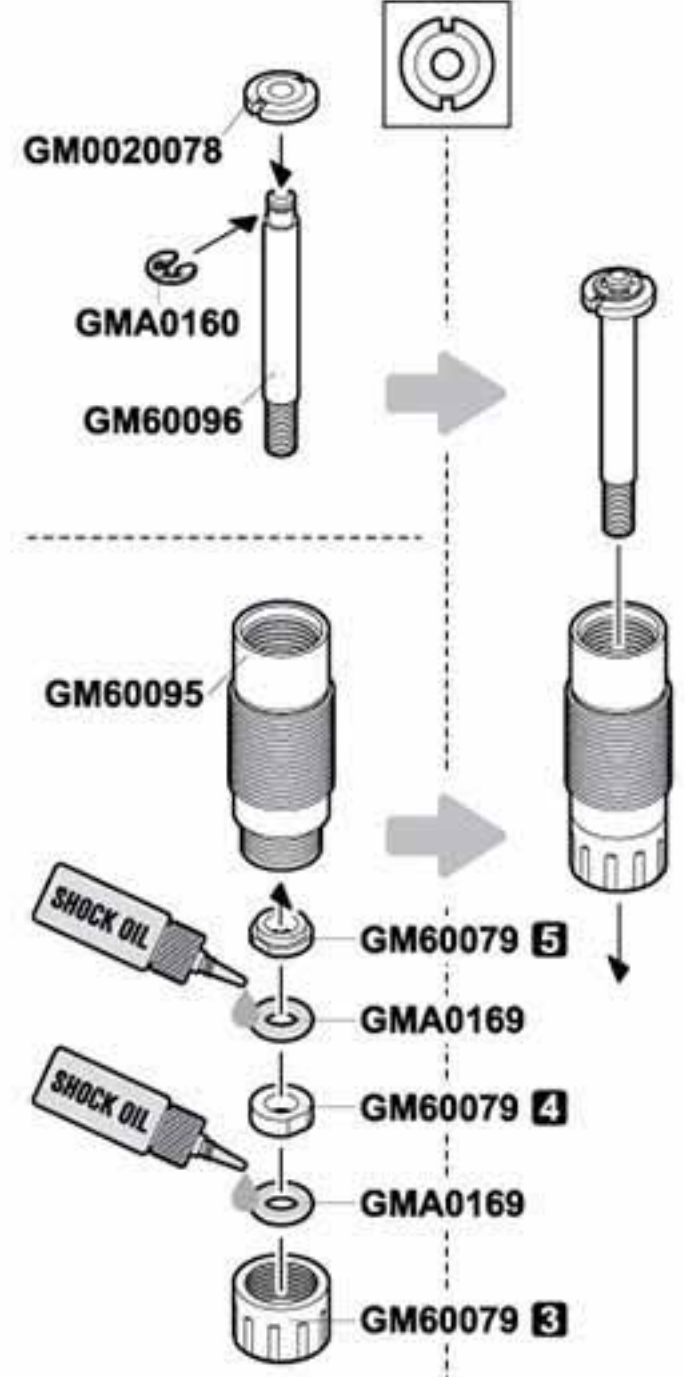

39 ⚠ MAKE X 4 : FRONT & REAR

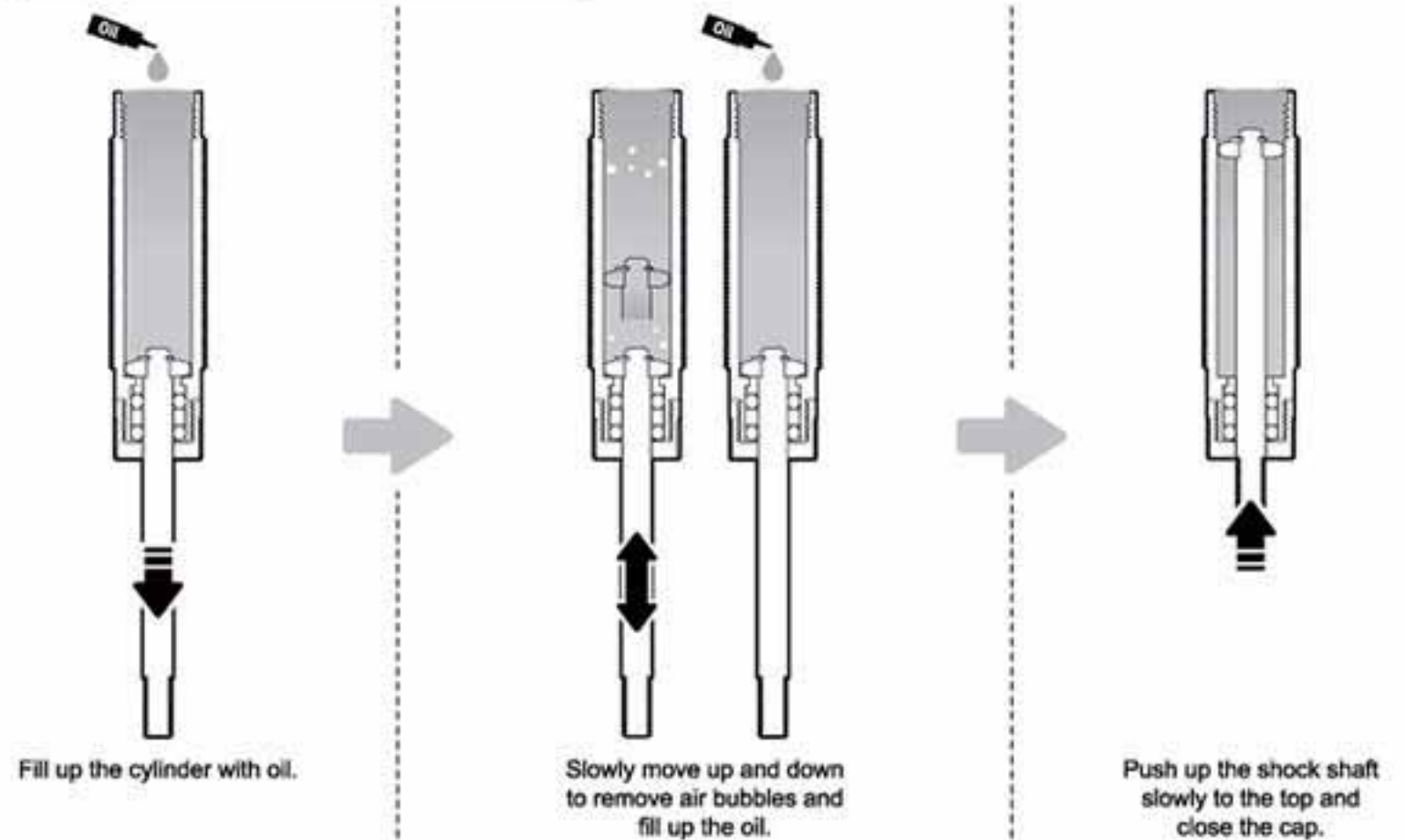

SLOWER REBOUND AND FASTER COMPRESSION

FASTER REBOUND AND SLOWER COMPRESSION

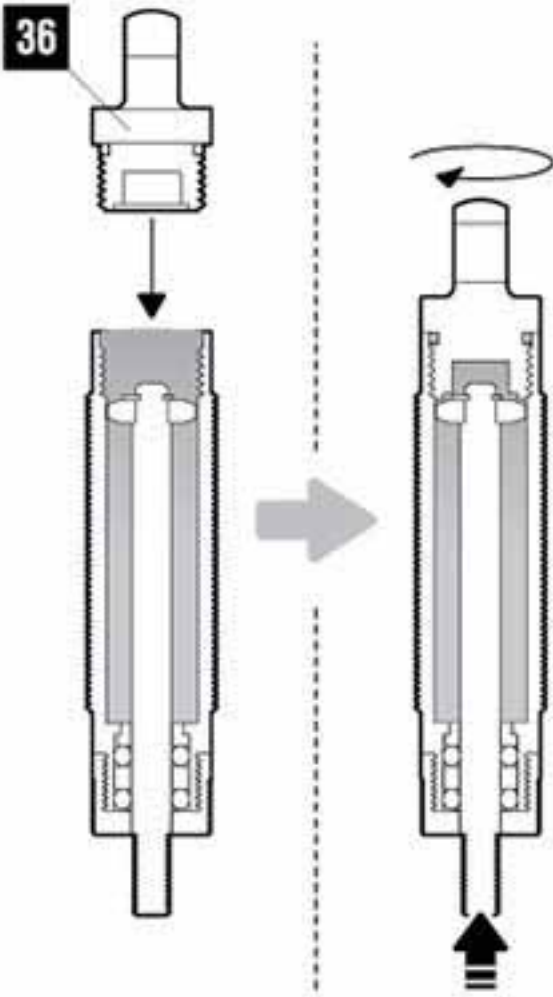

Push up the shock shaft slowly to the top and close the cap.

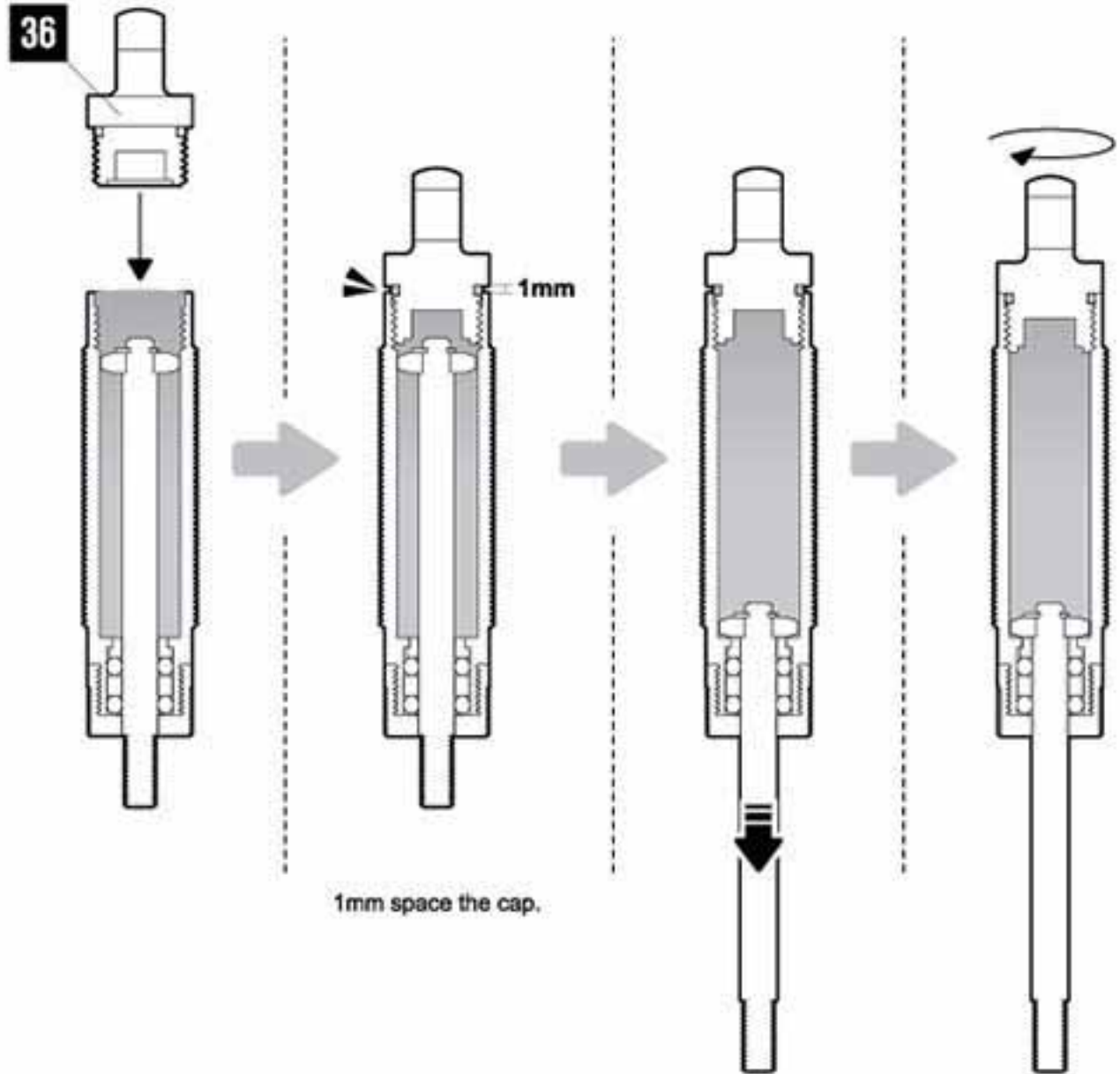

1mm space the cap.

Pull down the shock shaft slowly to the bottom.

close the cap.

40 ⚠ SD 90mm shock

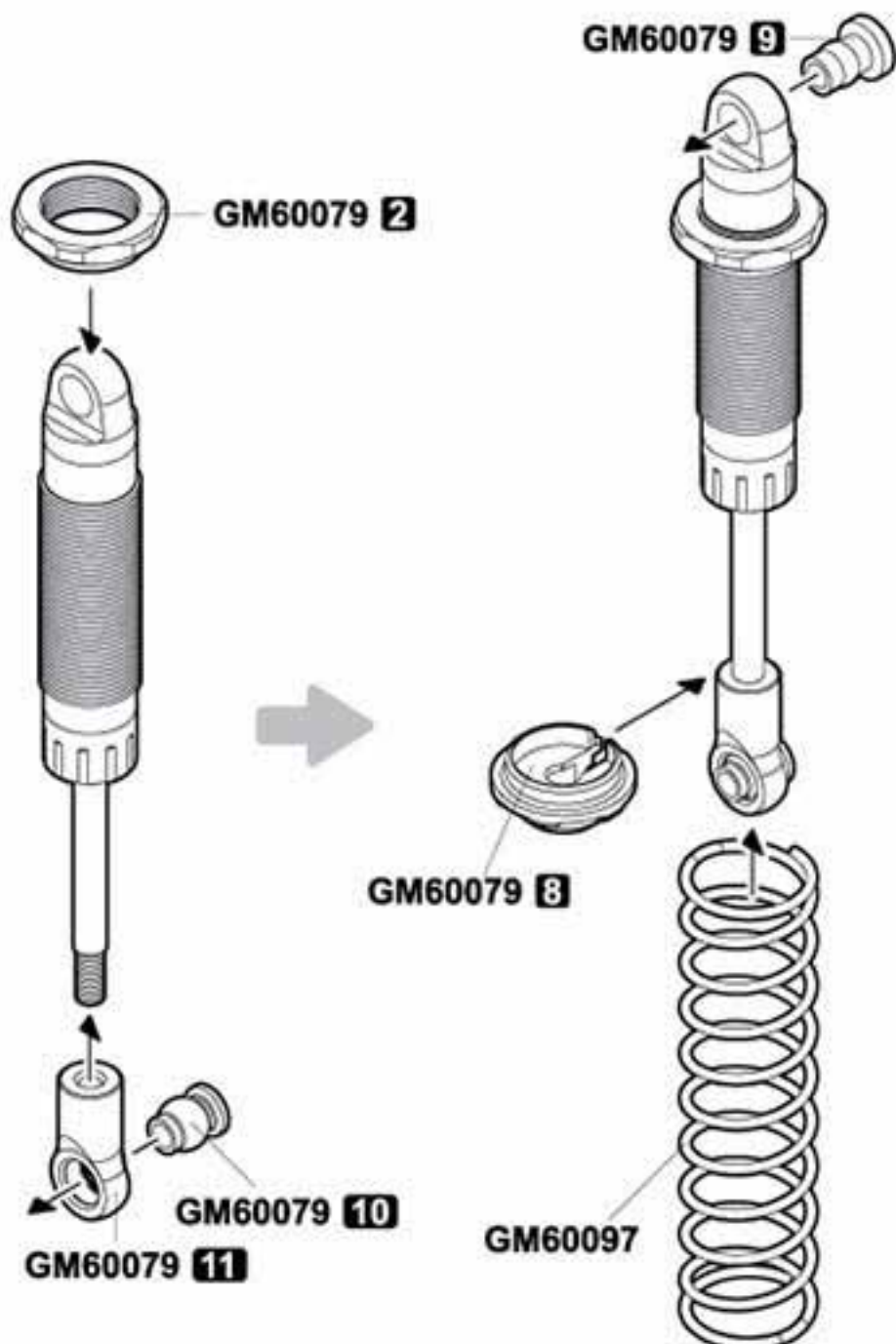

41 ⚠ SD 67mm shock

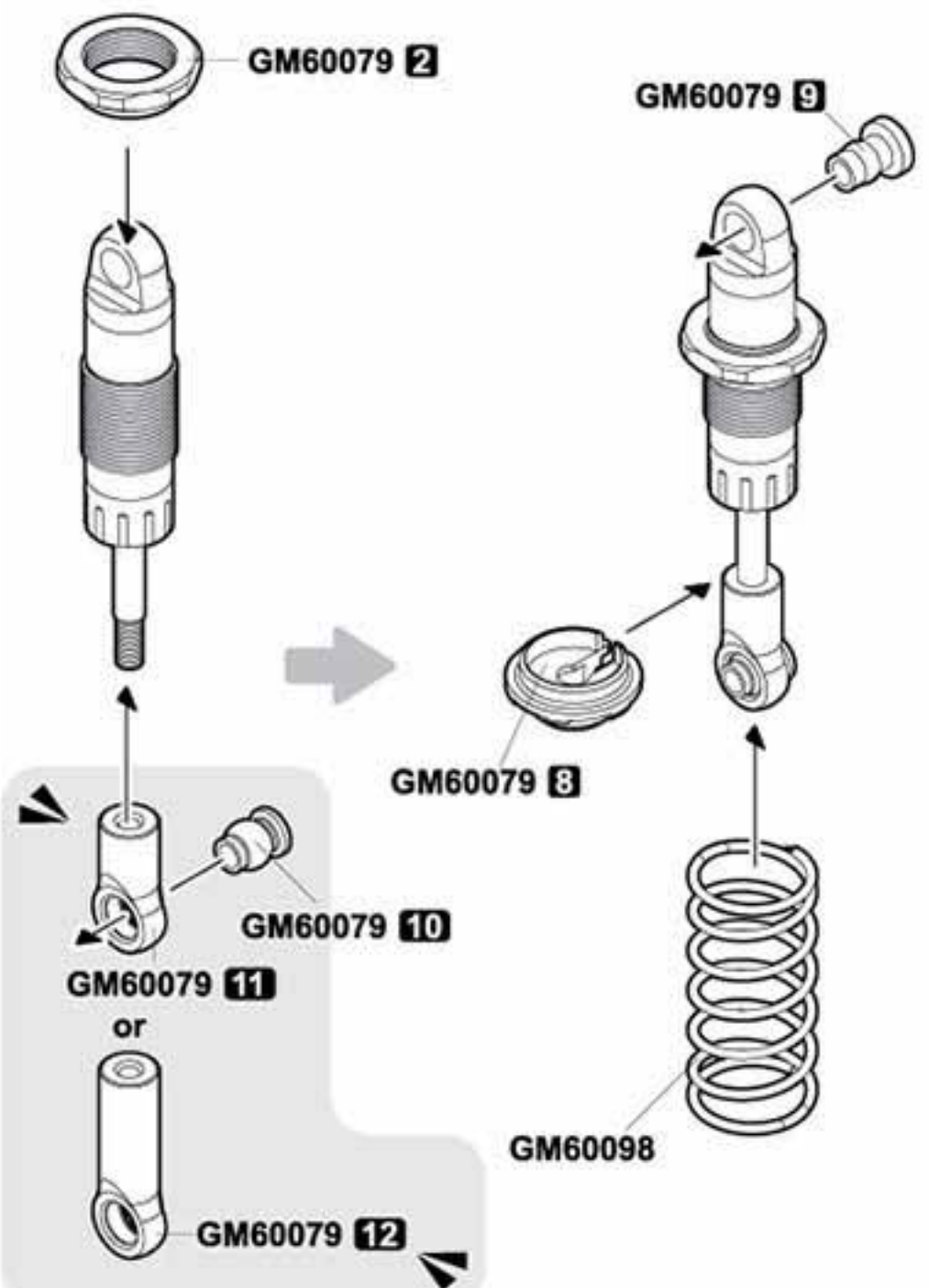

REAR AXLE

42



GMA0095
2.5X12mm Wrench bolt

x4

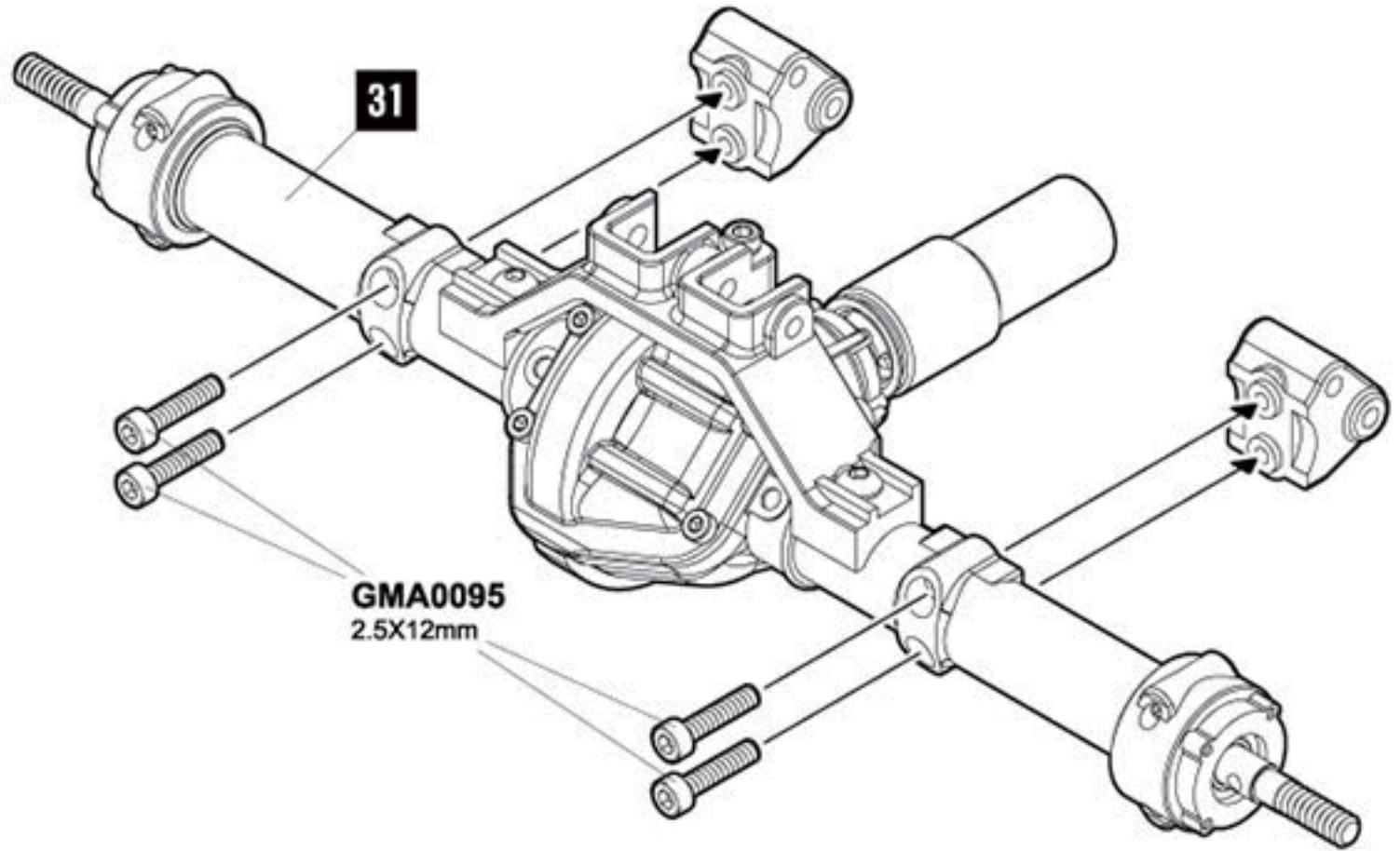

REAR SHOCK HOOP

CHASSIS

43



GMA0019
3X10mm
Round head wrench bolt

x2



GMA0191
M3 flange nut

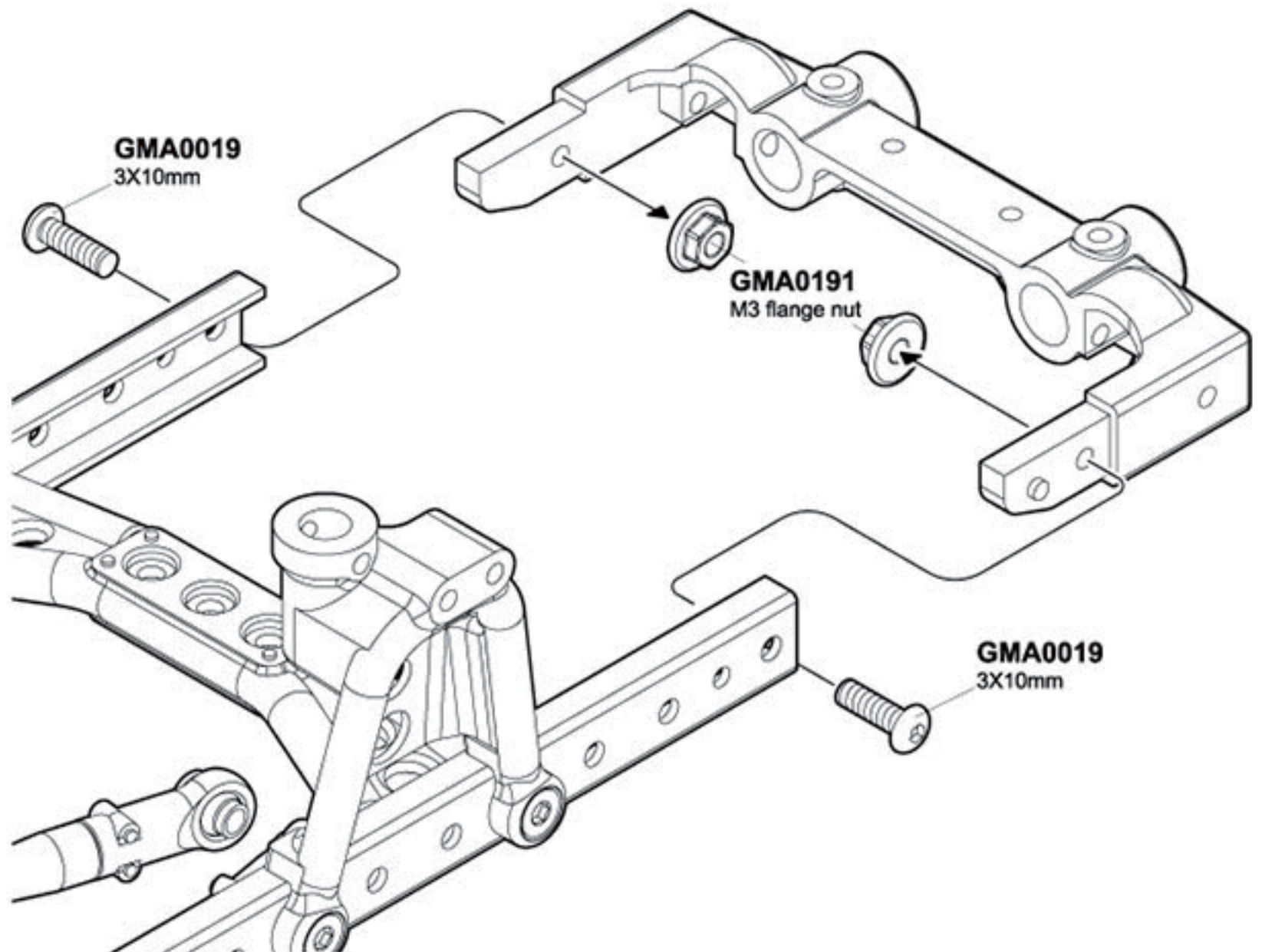

x2

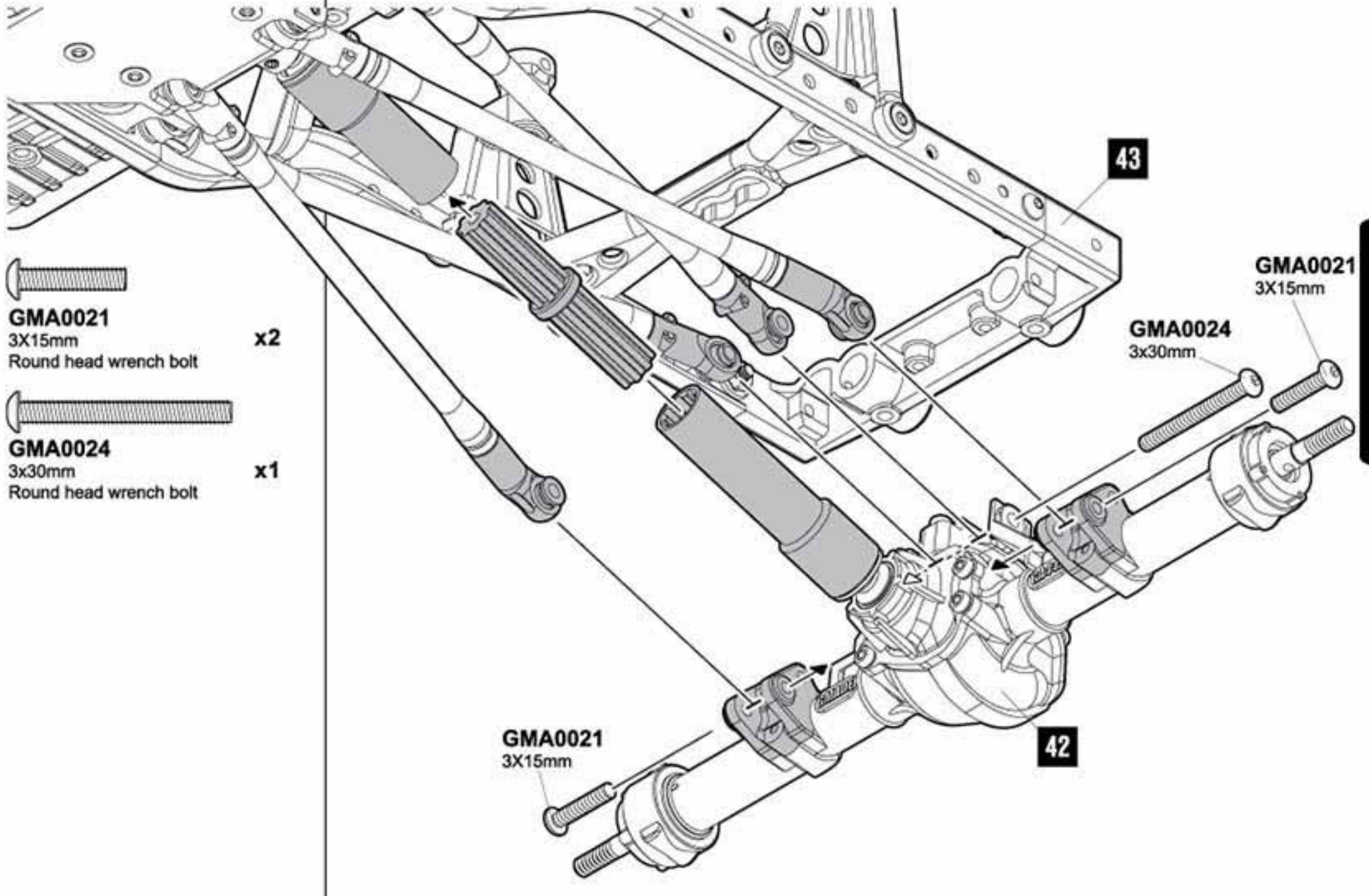

REAR AXLE

44





-  **GMA0021**
3X15mm
Round head wrench bolt **x2**
-  **GMA0024**
3x30mm
Round head wrench bolt **x1**

REAR SHOCK HOOP

REAR SHOCK ABSORBER

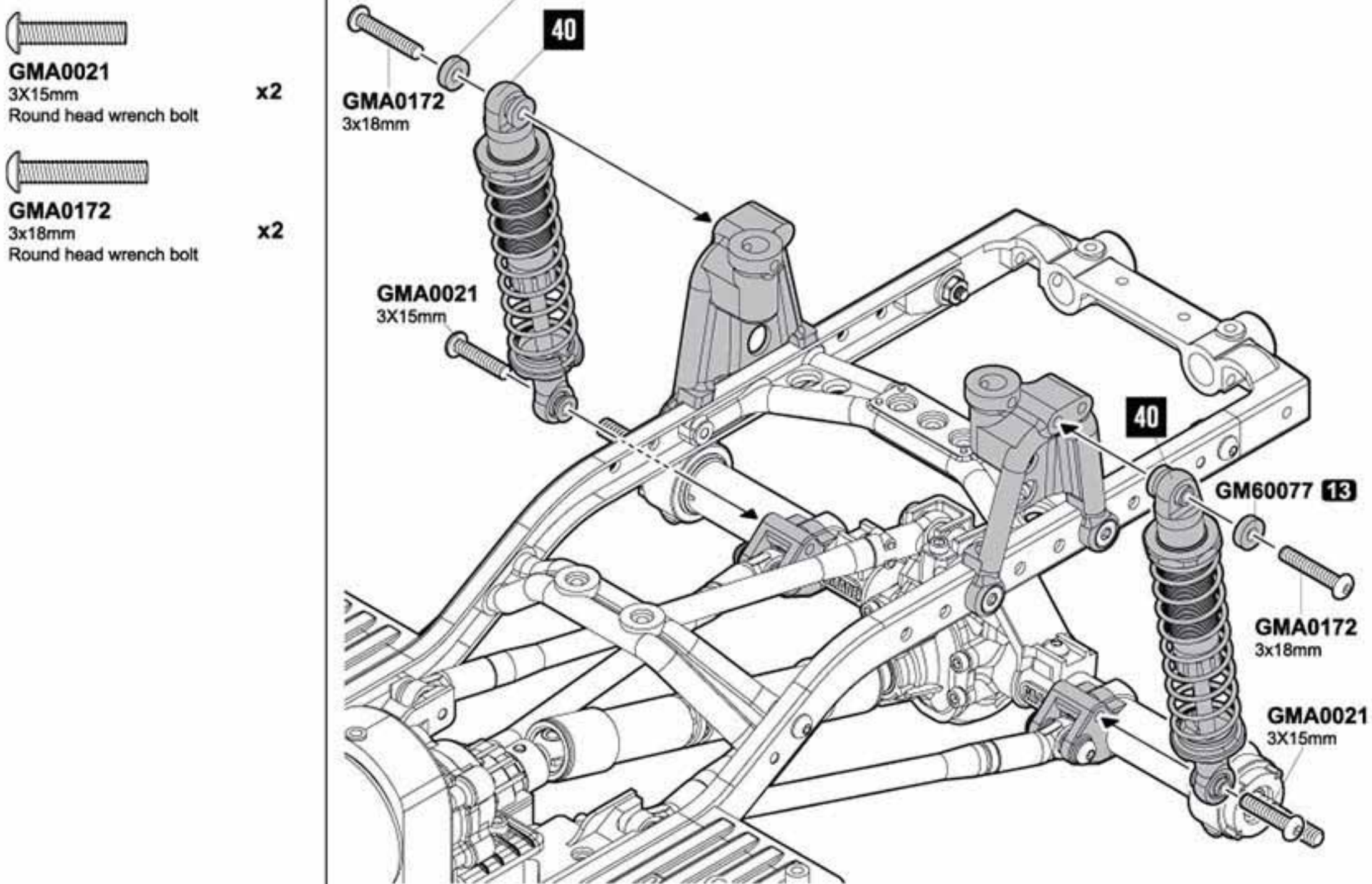
45



-  **GMA0021**
3X15mm
Round head wrench bolt **x2**
-  **GMA0172**
3x18mm
Round head wrench bolt **x2**

REAR AXLE

46



GMA0095
2.5X12mm Wrench bolt

x4

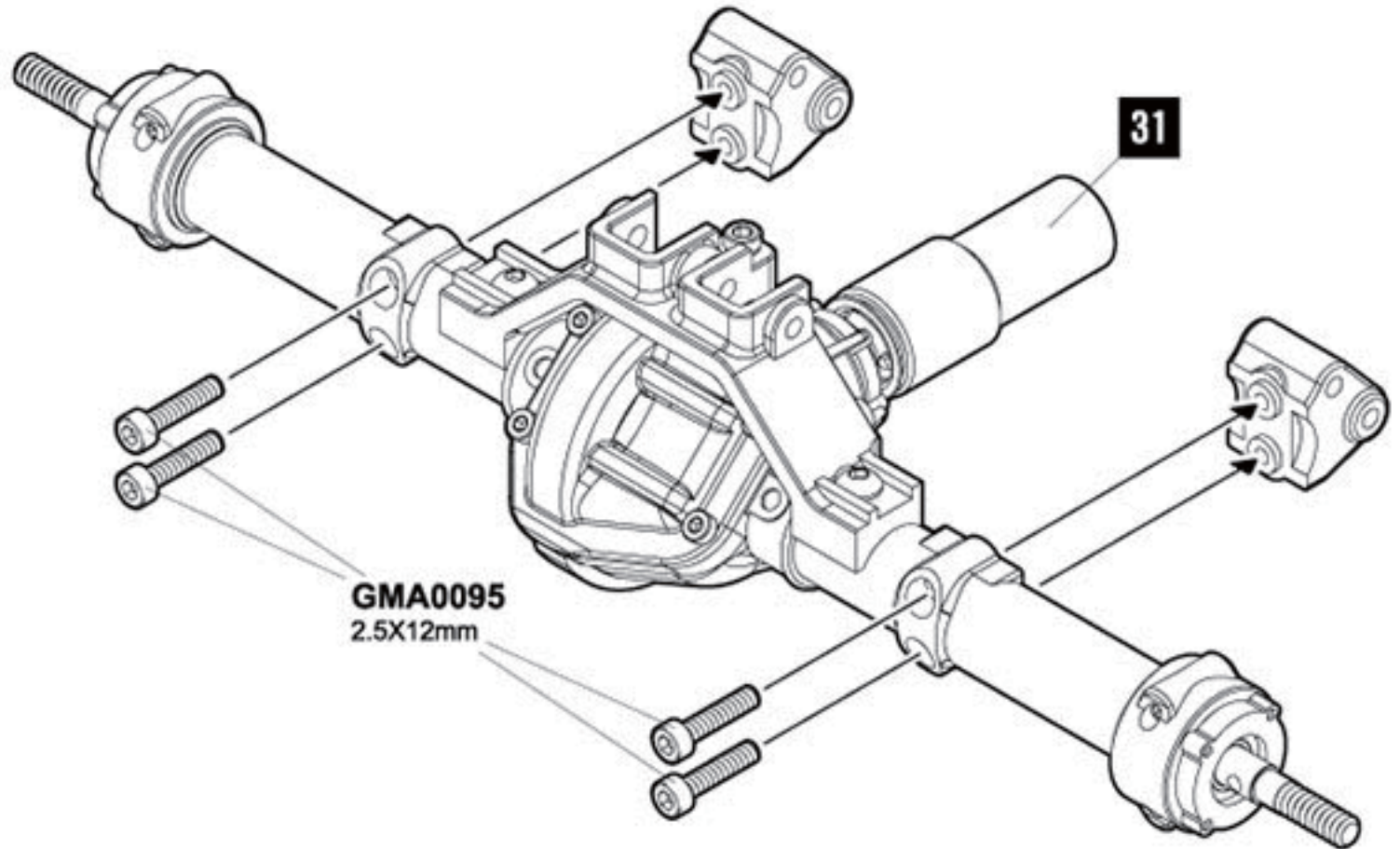

GMA0095
2.5X12mm



GMA0019
3X10mm
Round head wrench bolt

x2

47

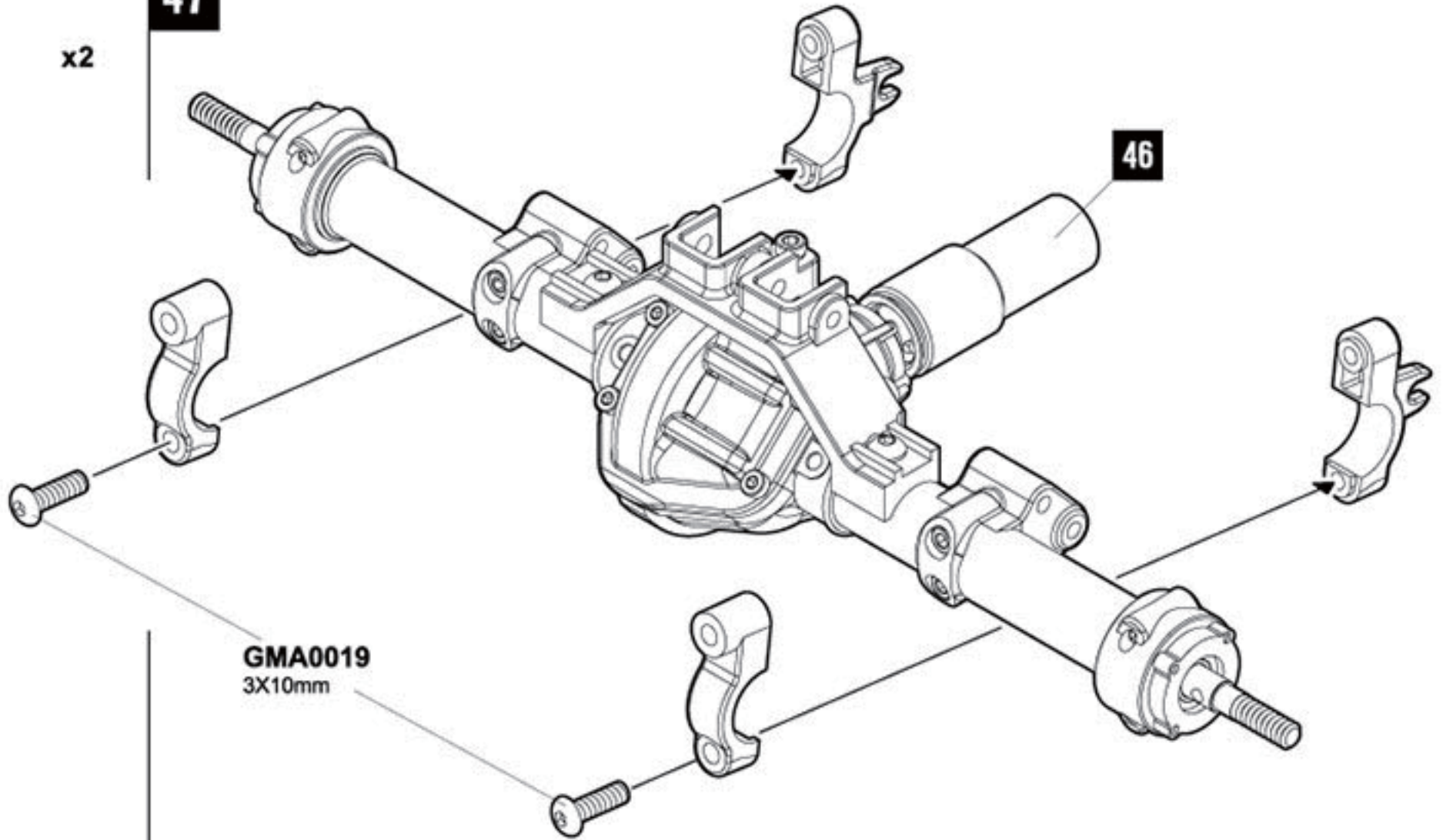

GMA0019
3X10mm

REAR SHOCK RELOCATION

CHASSIS

48



GMA0019
3X10mm
Round head wrench bolt

x2



GMA0191
M3 flange nut

x2

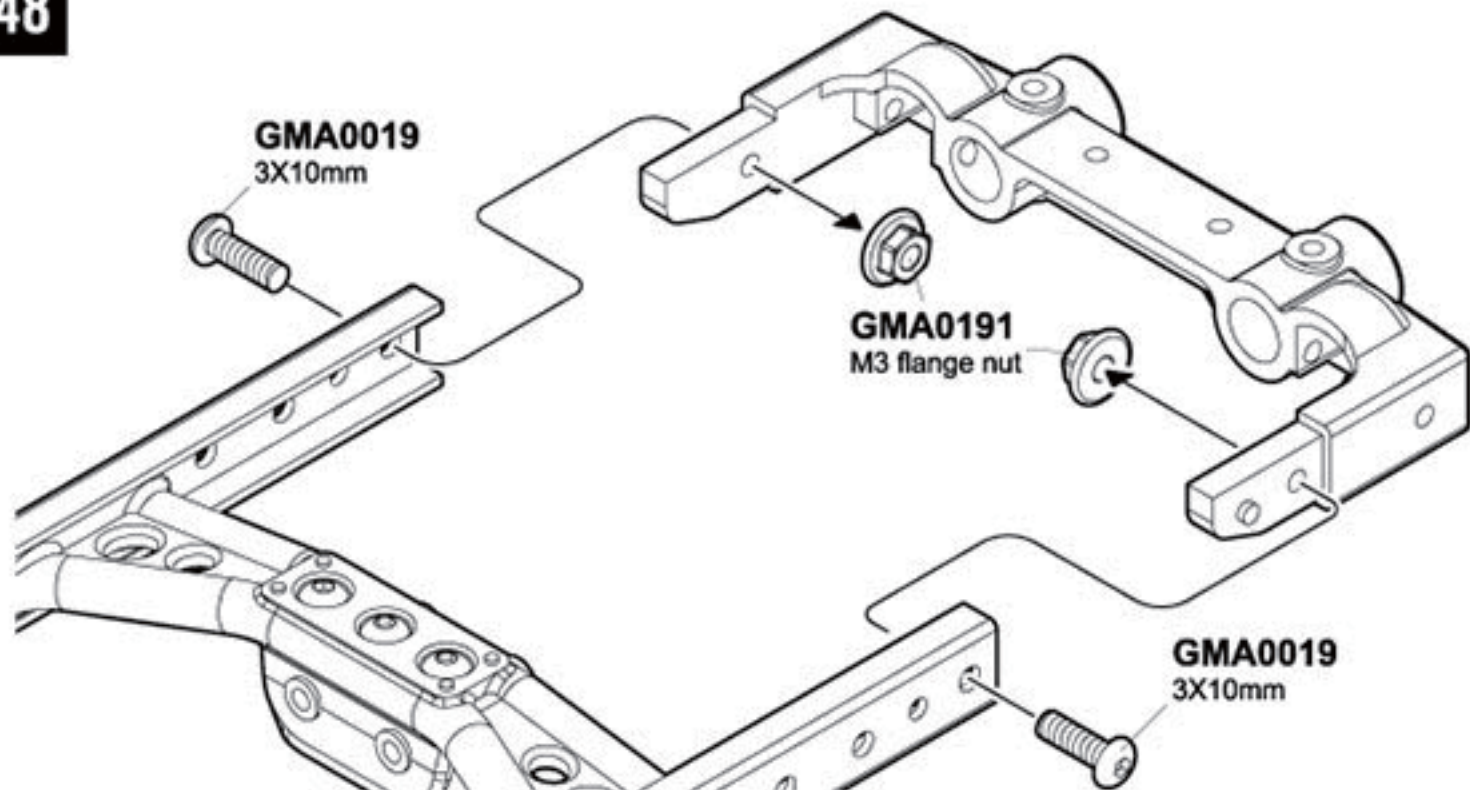

GMA0019
3X10mm

GMA0191
M3 flange nut

GMA0019
3X10mm

REAR AXLE

49

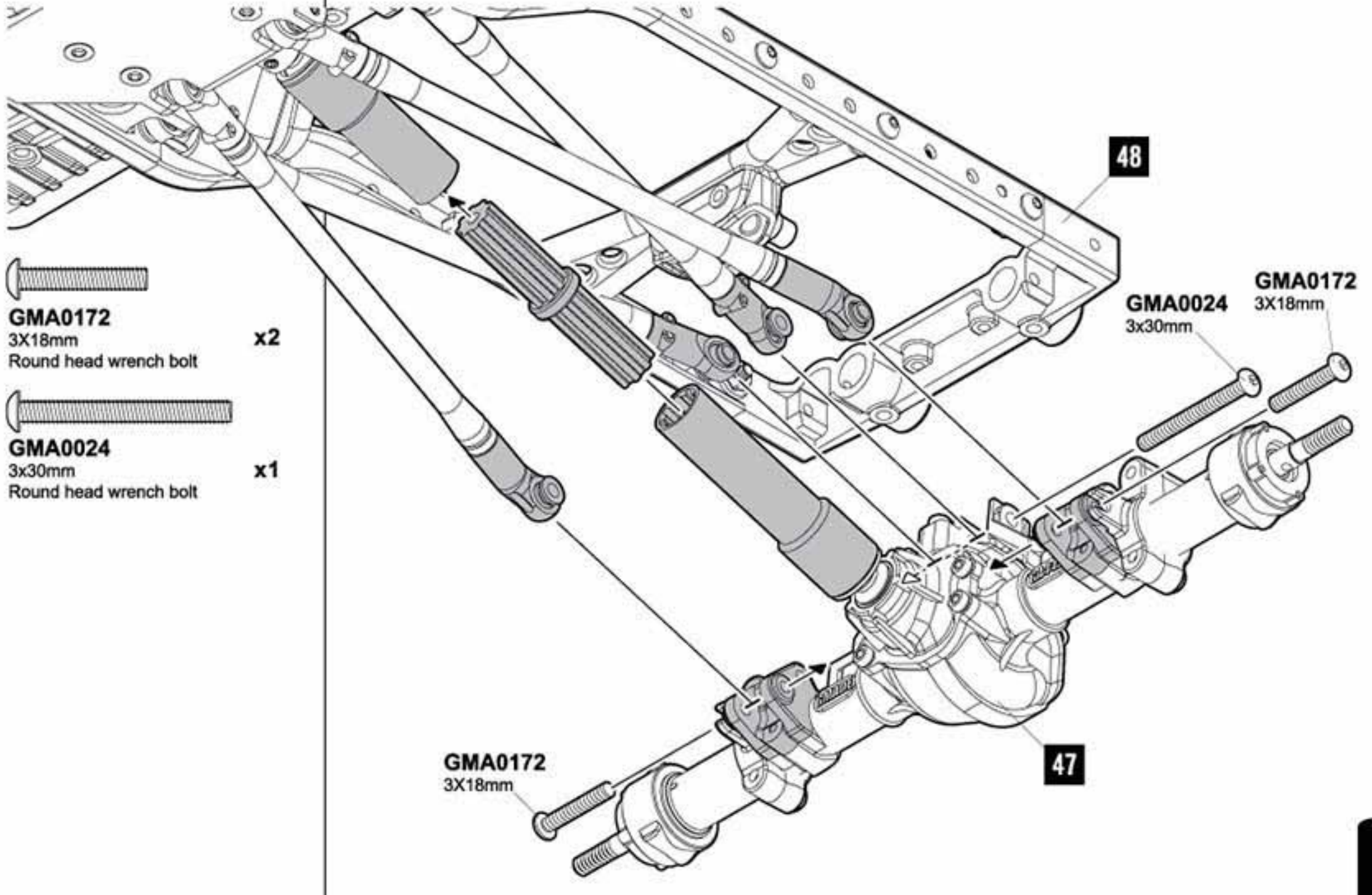

REAR SHOCK ABSORBER

50

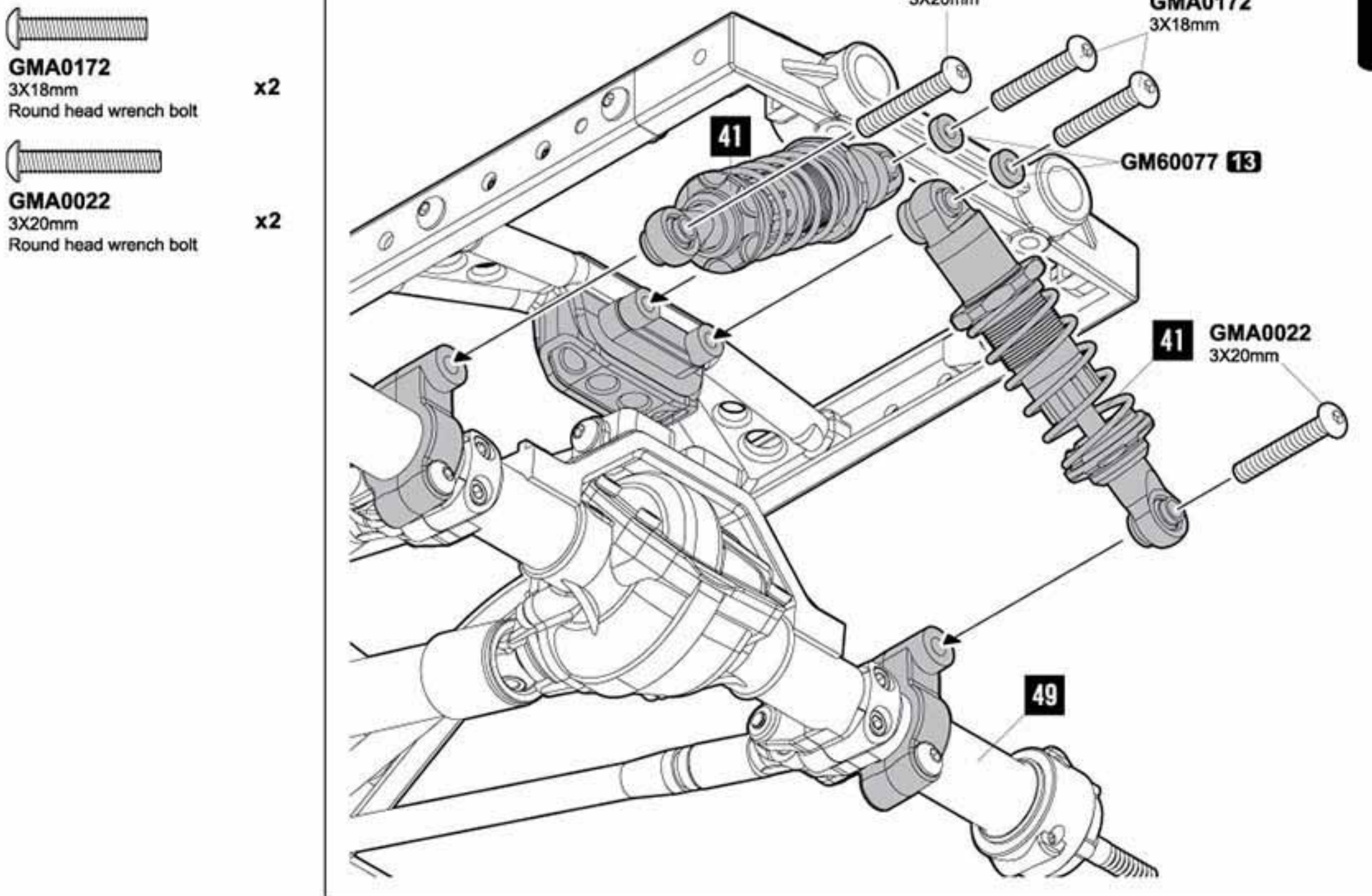

REAR SHOCK RELOCATION

REAR SHOCK HOOP

51

⚠ GM60077 3, GM60077 4 is a selection option by your body shape.

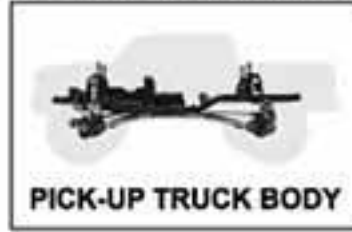

GMA0058
3X10mm
Flat head wrench bolt

x4

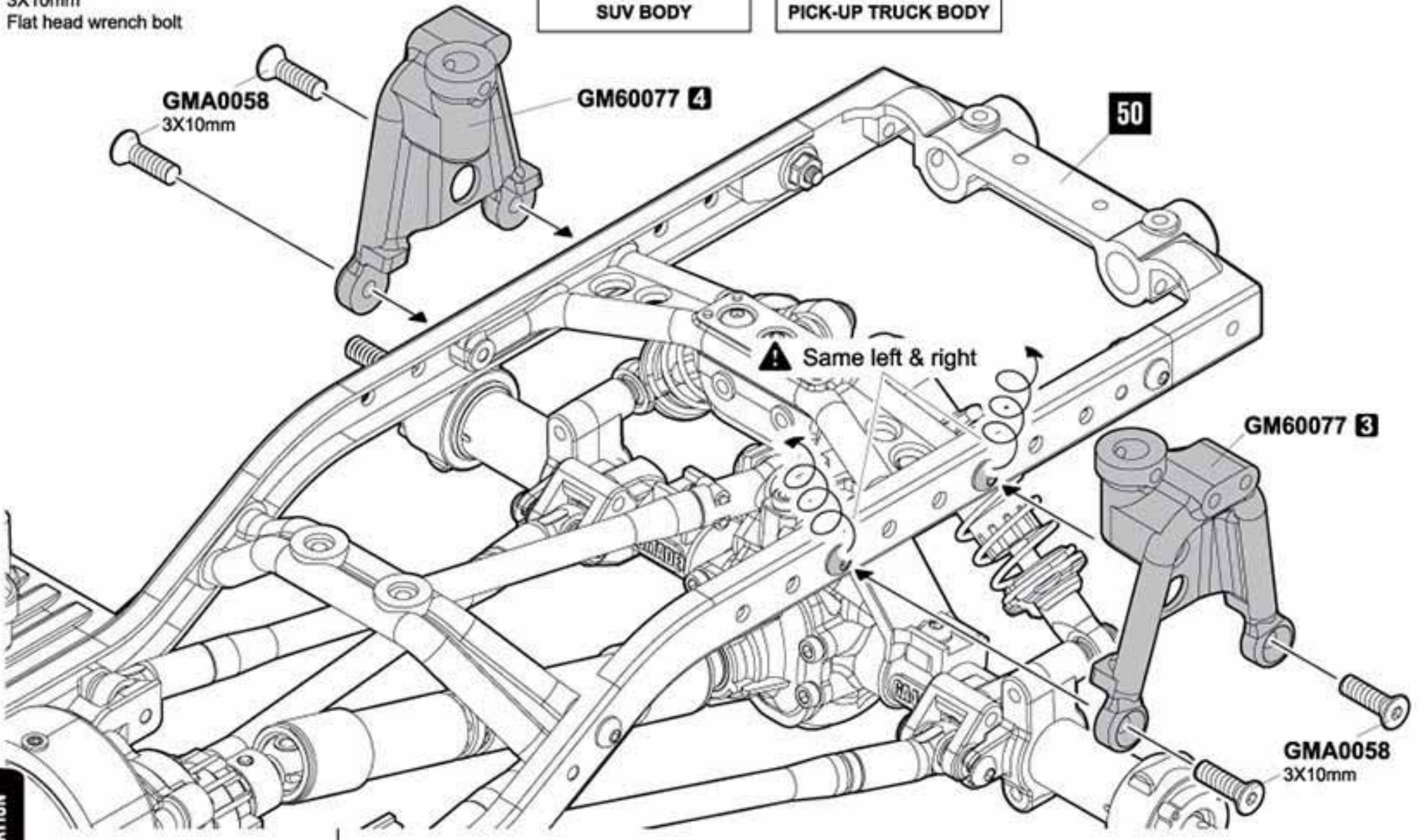

REAR SHOCK RELOCATION

CANTILEVER

52

GMA0156
M3 Nylon lock nut

x2

GMA0172
3x18mm

GM60075 5

GMA0172
3x18mm

GM60075 3

GM60023 3

GMA0012
2.5x8mm

GM60075 2

GMA0172
3x18mm

GM60023 1 GM60075 8

GMA0156

GM60075 4

GM60023 3

GM60075 1

GMA0012
2.5x8mm
Round head wrench bolt

x2

GMA0172
3x18mm
Round head wrench bolt

x4



GM60075 8 GM60023 1

GMA0172
3x18mm

REAR CANTILEVER

CANTILEVER

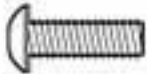
53

-  **GMA0017**
3x6mm
Round head wrench bolt **x2**
-  **GMA0019**
3x10mm
Round head wrench bolt **x4**
-  **GMA0021**
3x15mm
Round head wrench bolt **x4**
-  **GMA0057**
3x8mm Flat head wrench bolt **x2**

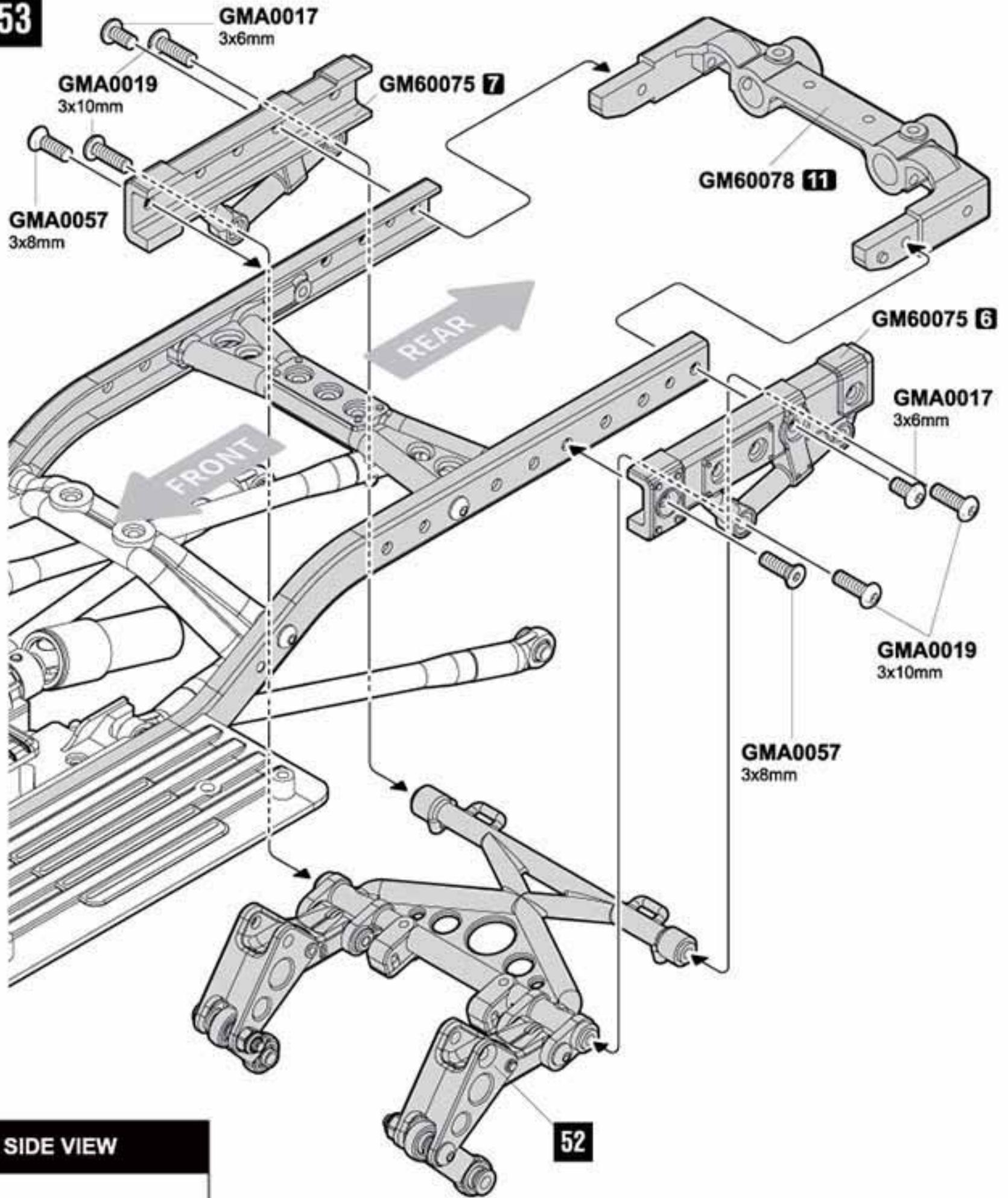

⚠ CANTILEVER BOTTOM & SIDE VIEW

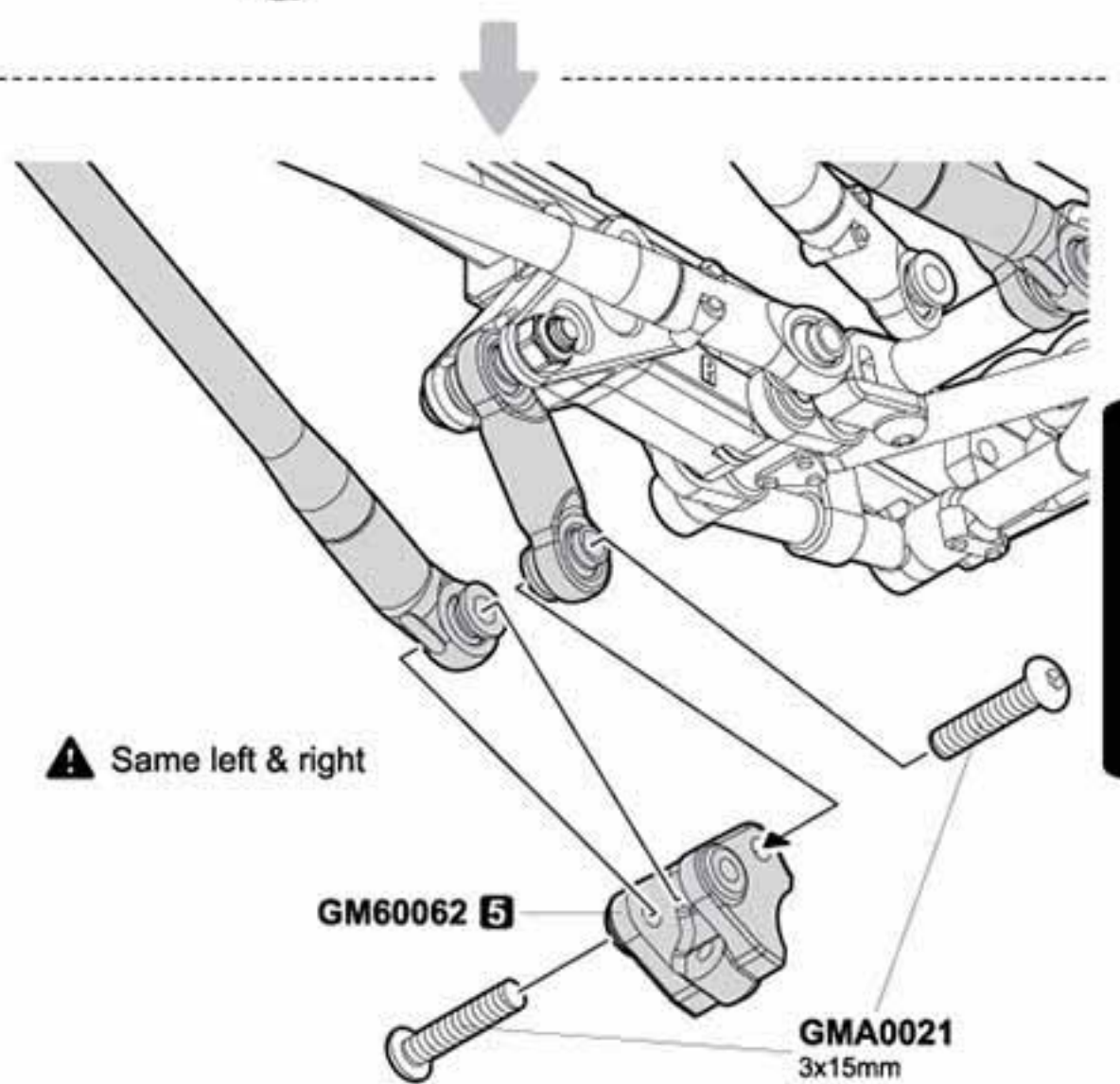
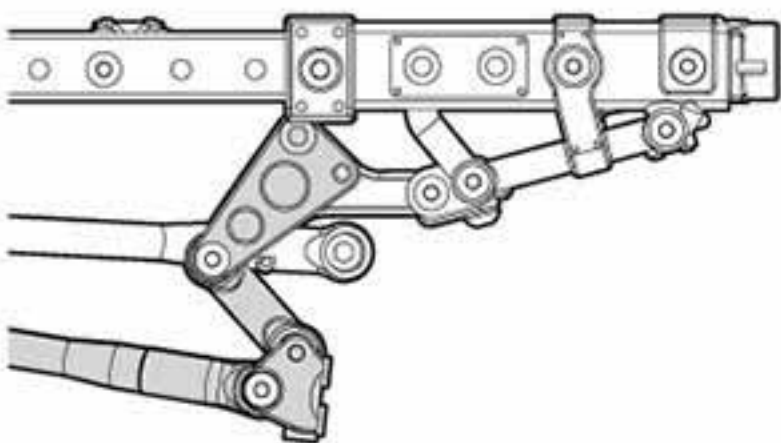
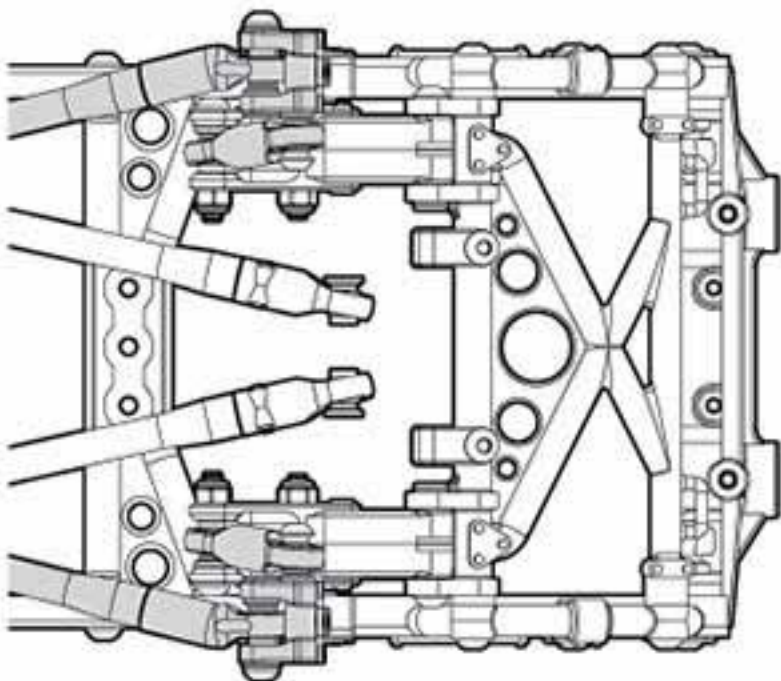

REAR SHOCK ABSORBER

54



GMA0022
3x20mm
Round head wrench bolt
x2



GMA0211
3x18mm Flat head wrench bolt
x2



GMA0156
M3 Nylon lock nut
x2

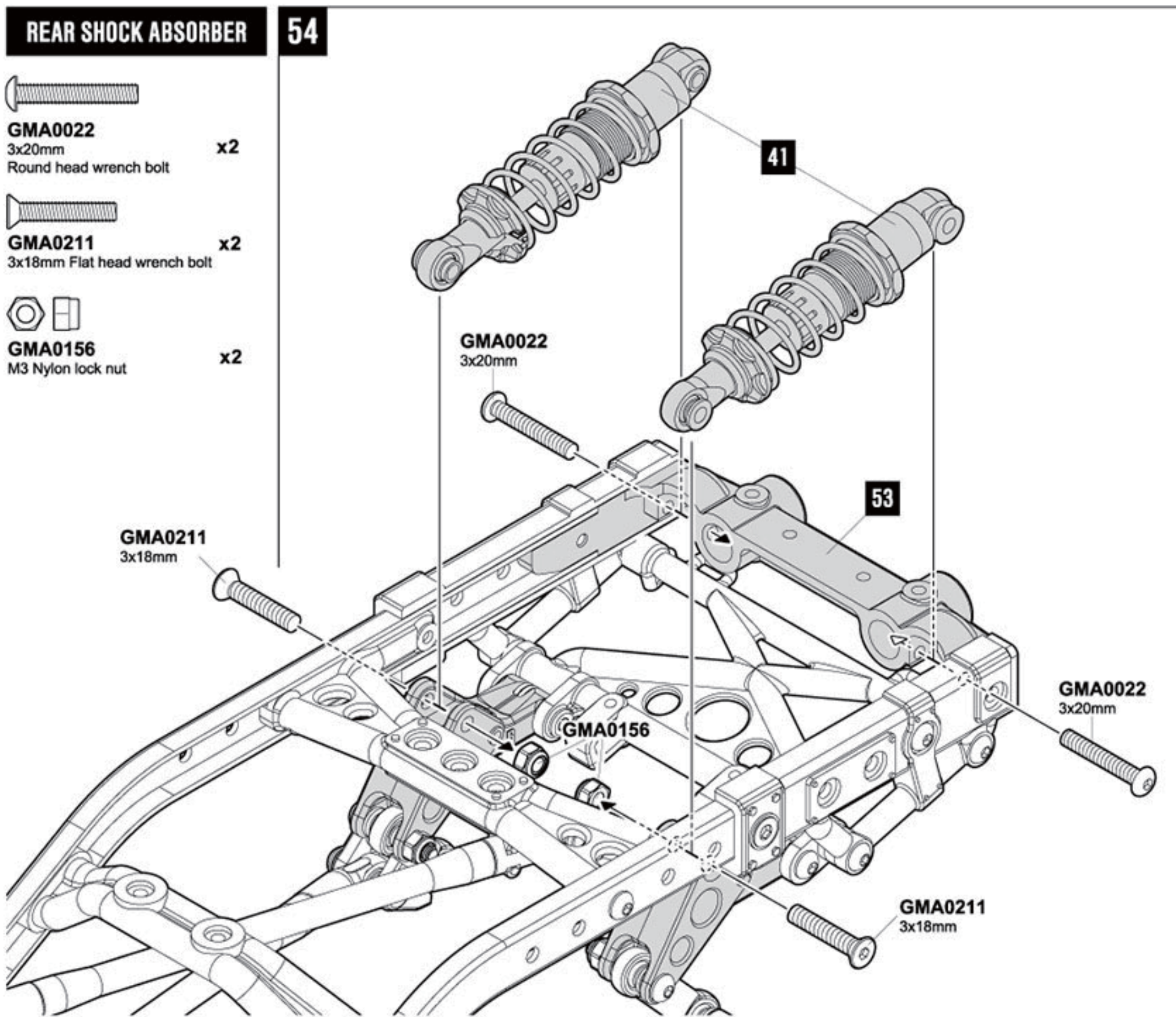

⚠ CANTILEVER TOP VIEW

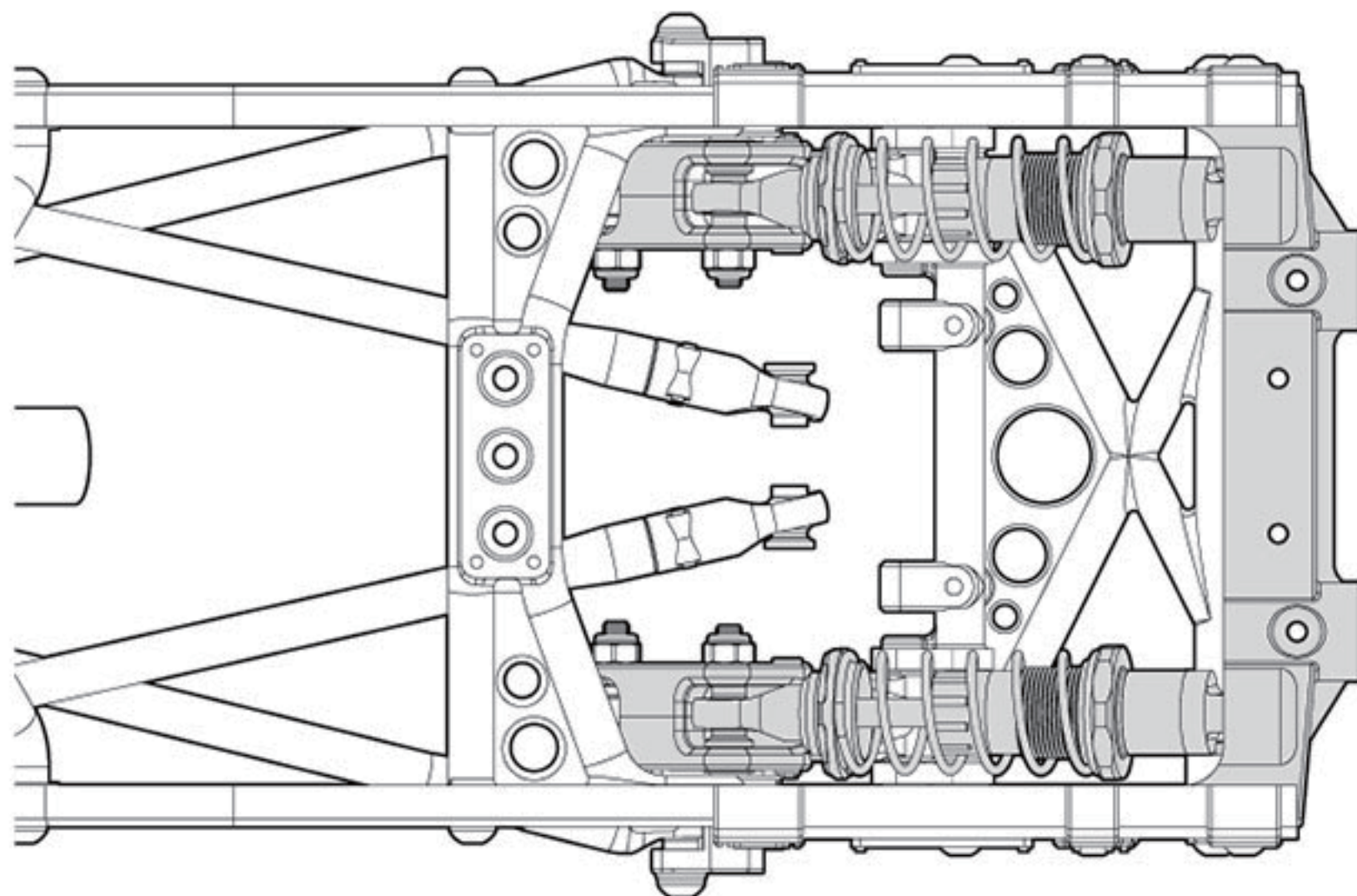

REAR CANTILEVER

REAR AXLE

55

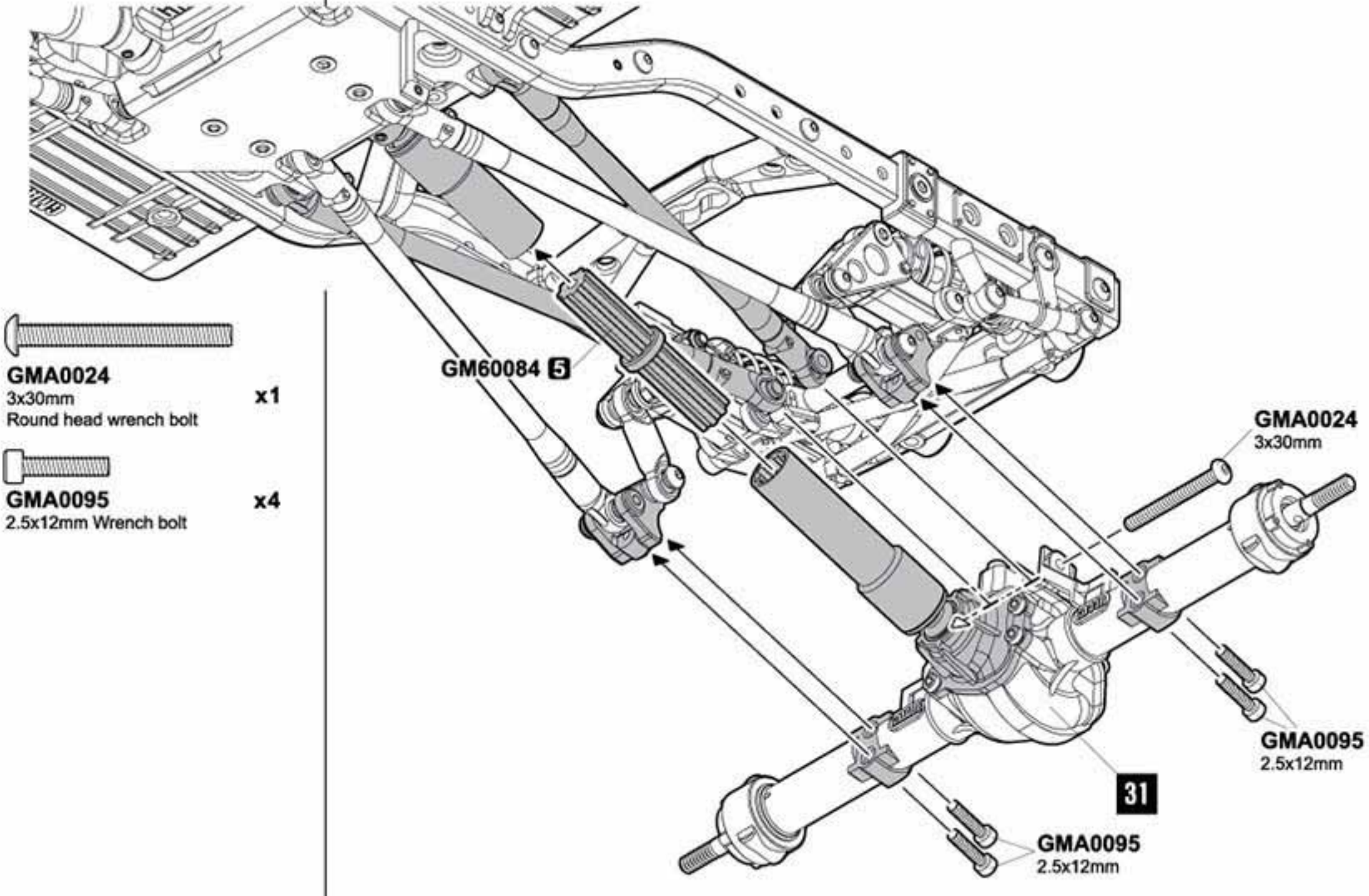

REAR BODY MOUNT

56

⚠ **GM60077 5** is a selection option by your body shape.

-  **GMA0018**
3X8mm
Round head wrench bolt **x2**

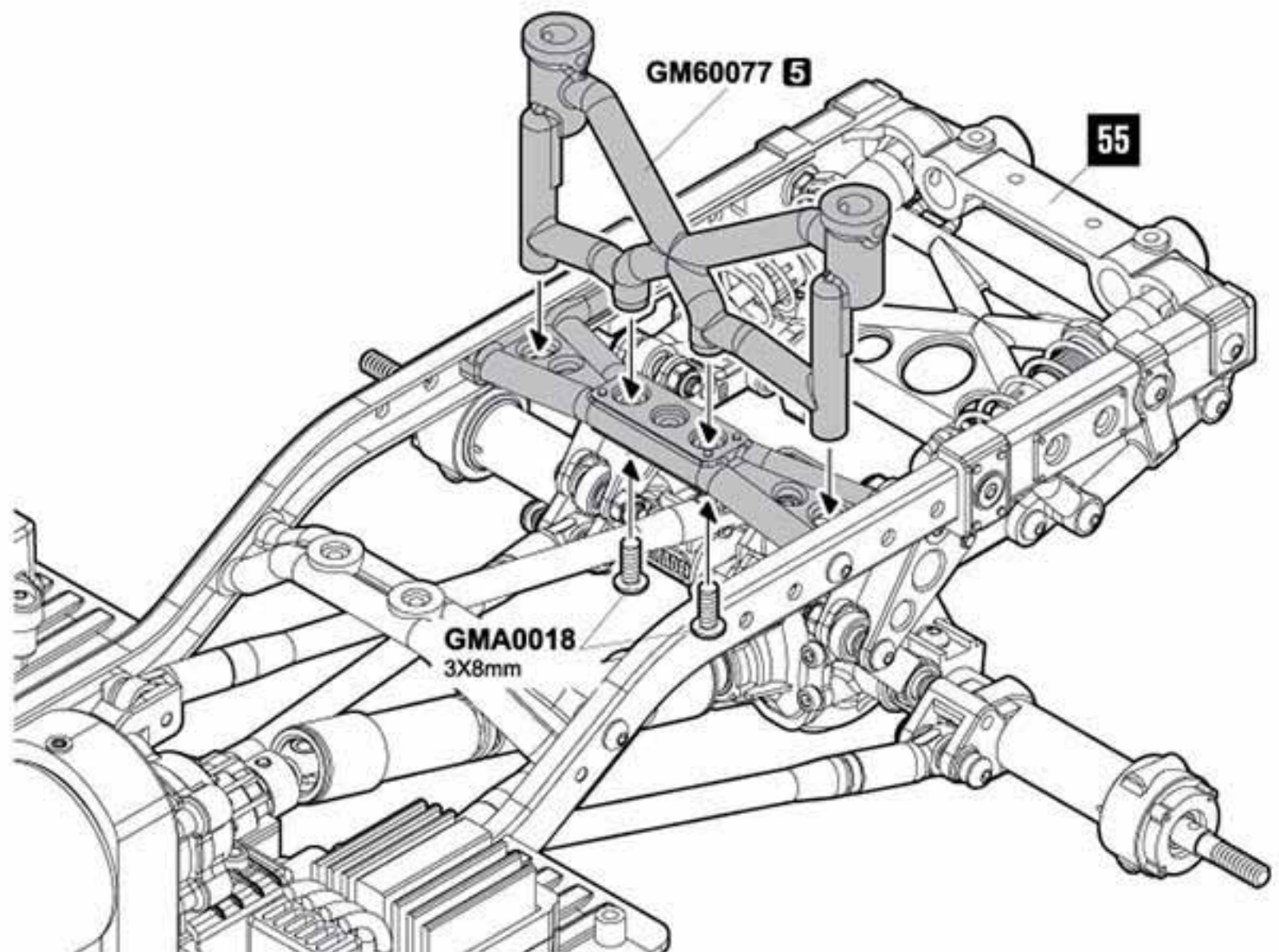
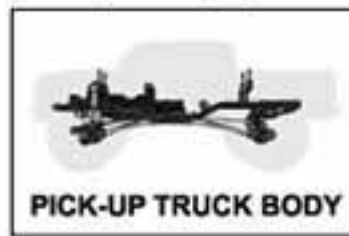
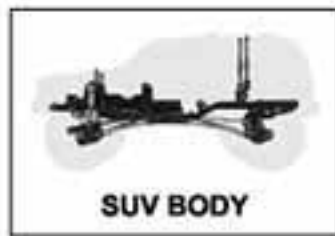

REAR CANTILEVER

FRONT SHOCK ABSORBER

57

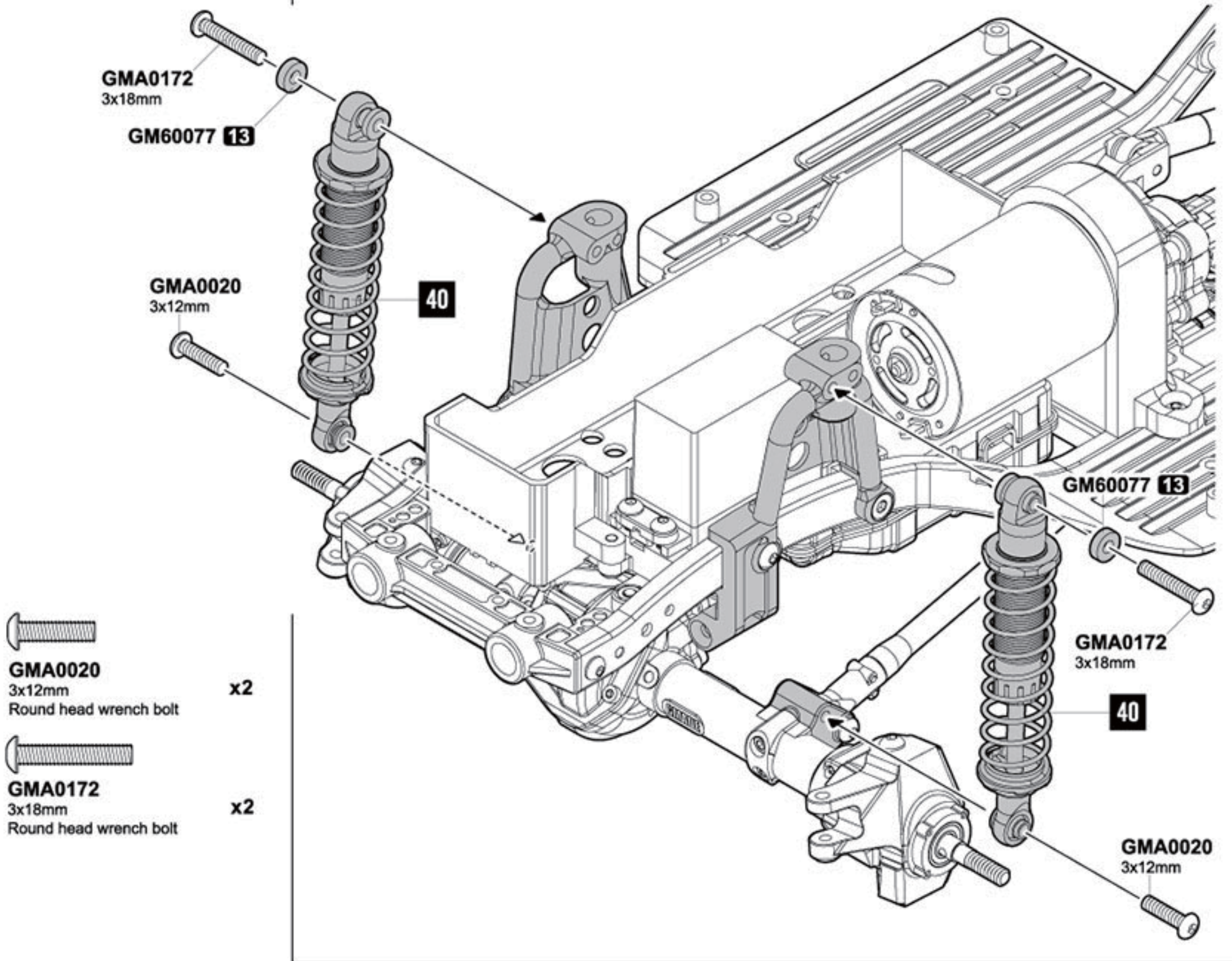

PANHARD ROD

58

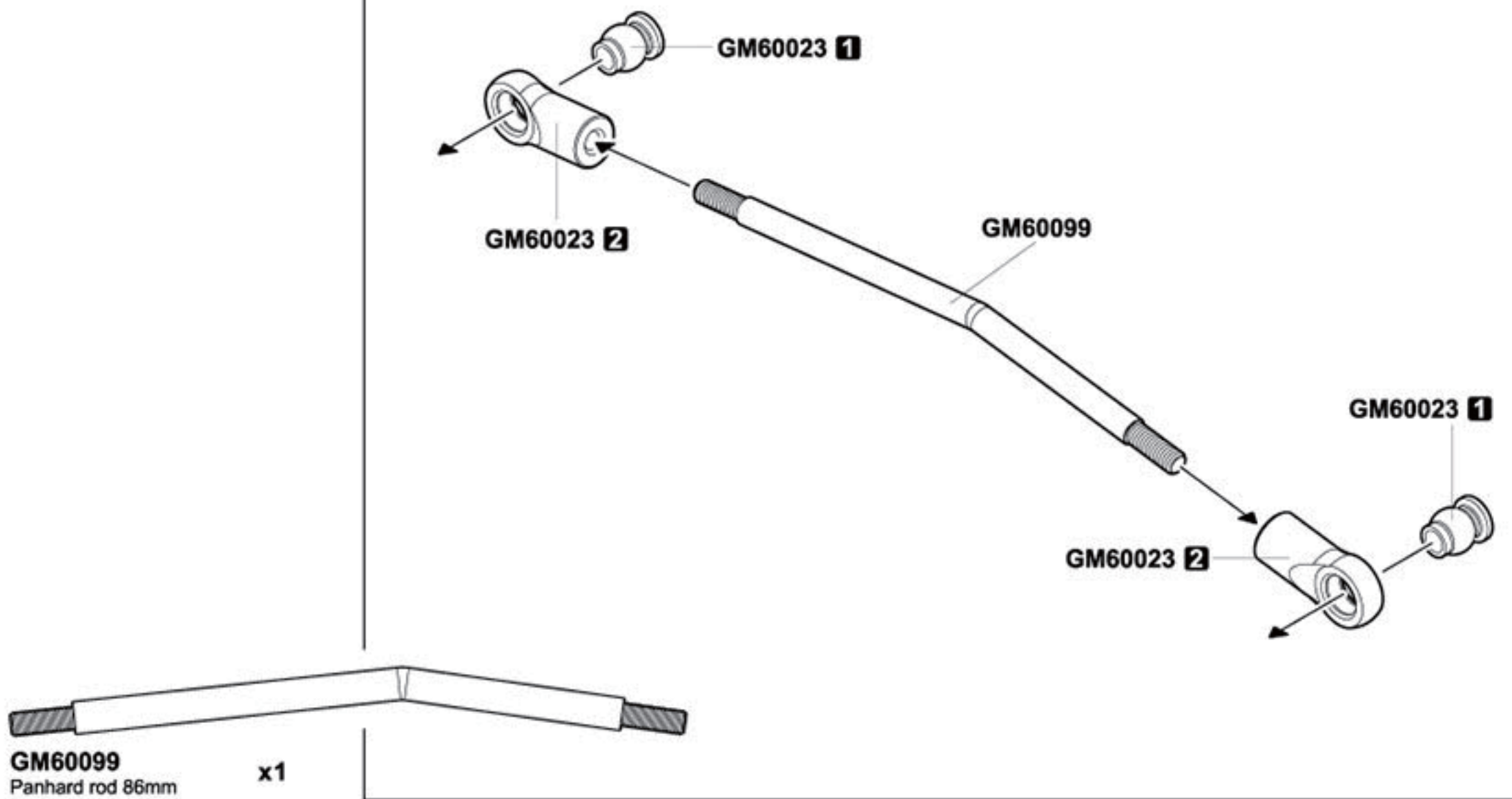

PANHARD ROD

59



GMA0021
3x15mm
Round head wrench bolt x1



GMA0060
3x15mm
Flat head wrench bolt x1

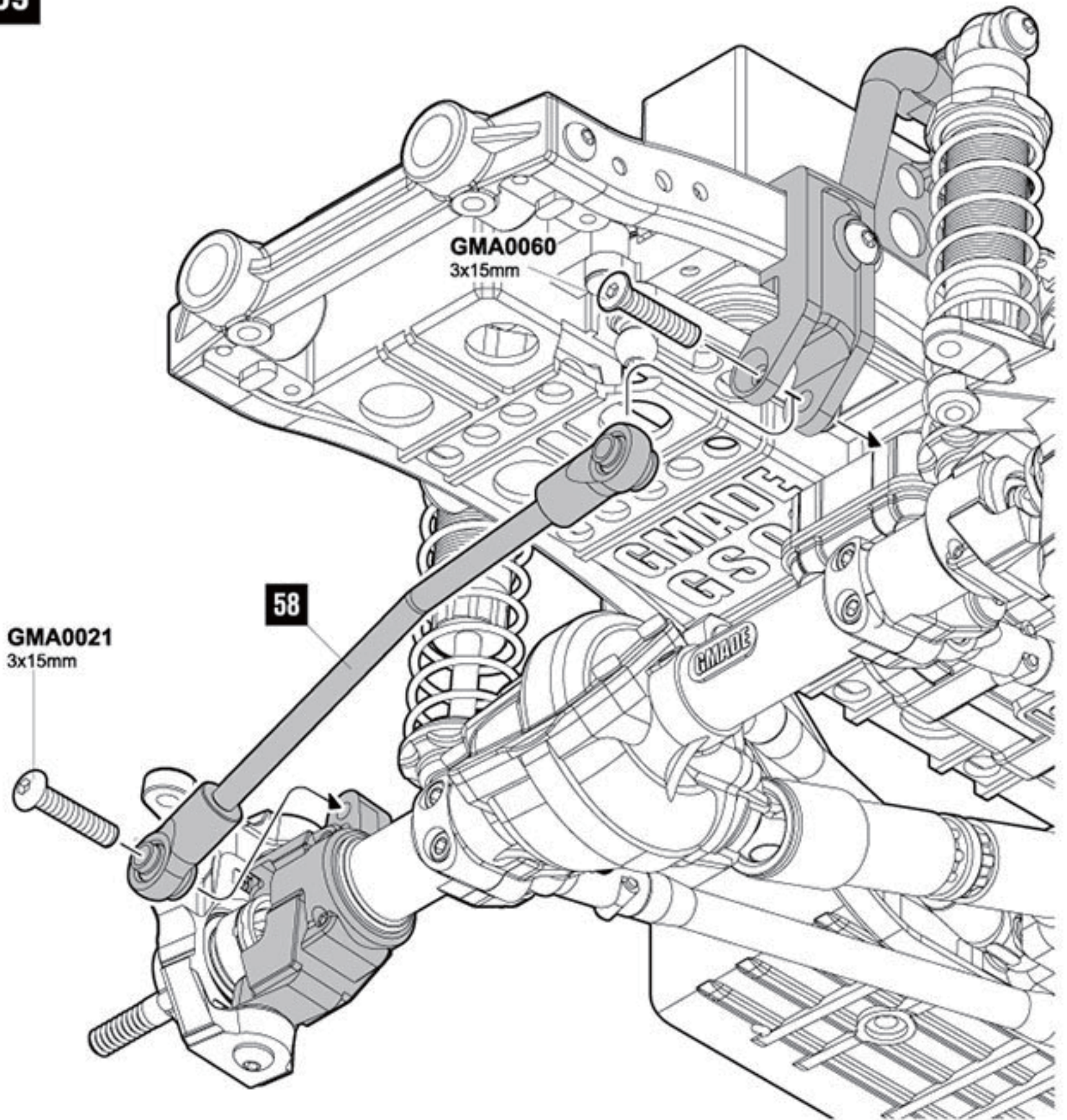

STEERING ROD

60

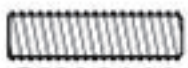

GMA0144
4x15mm Socket set screw x2



GMA0145
4x20mm Socket set screw x2



GM60100
Steering rod M4x6.8x69mm x1



GM60100
Steering rod M4x6.8x115mm x1

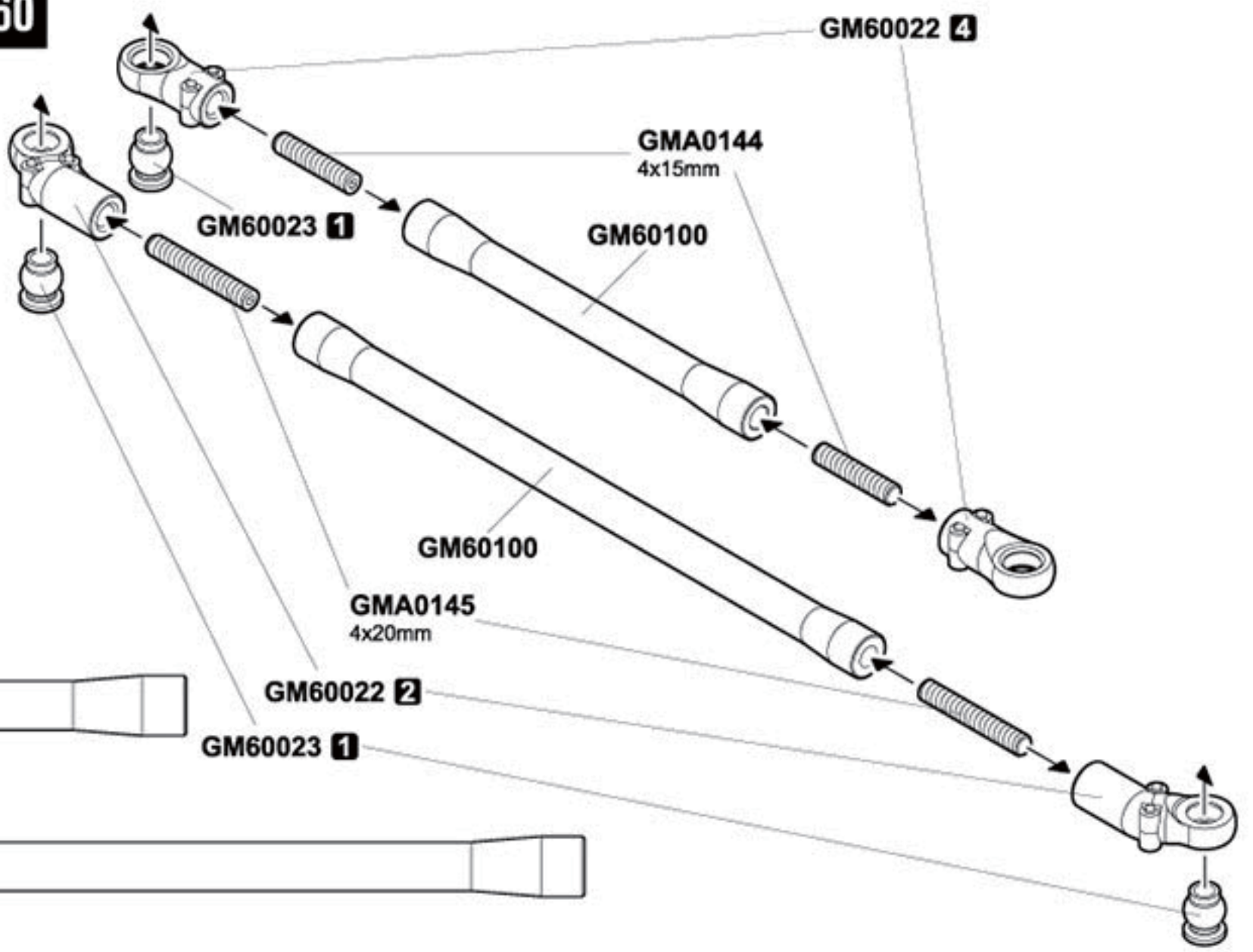

STEERING ROD

61



GMA0021
3x15mm
Round head wrench bolt

x1



GMA0023
3x25mm
Round head wrench bolt

x1

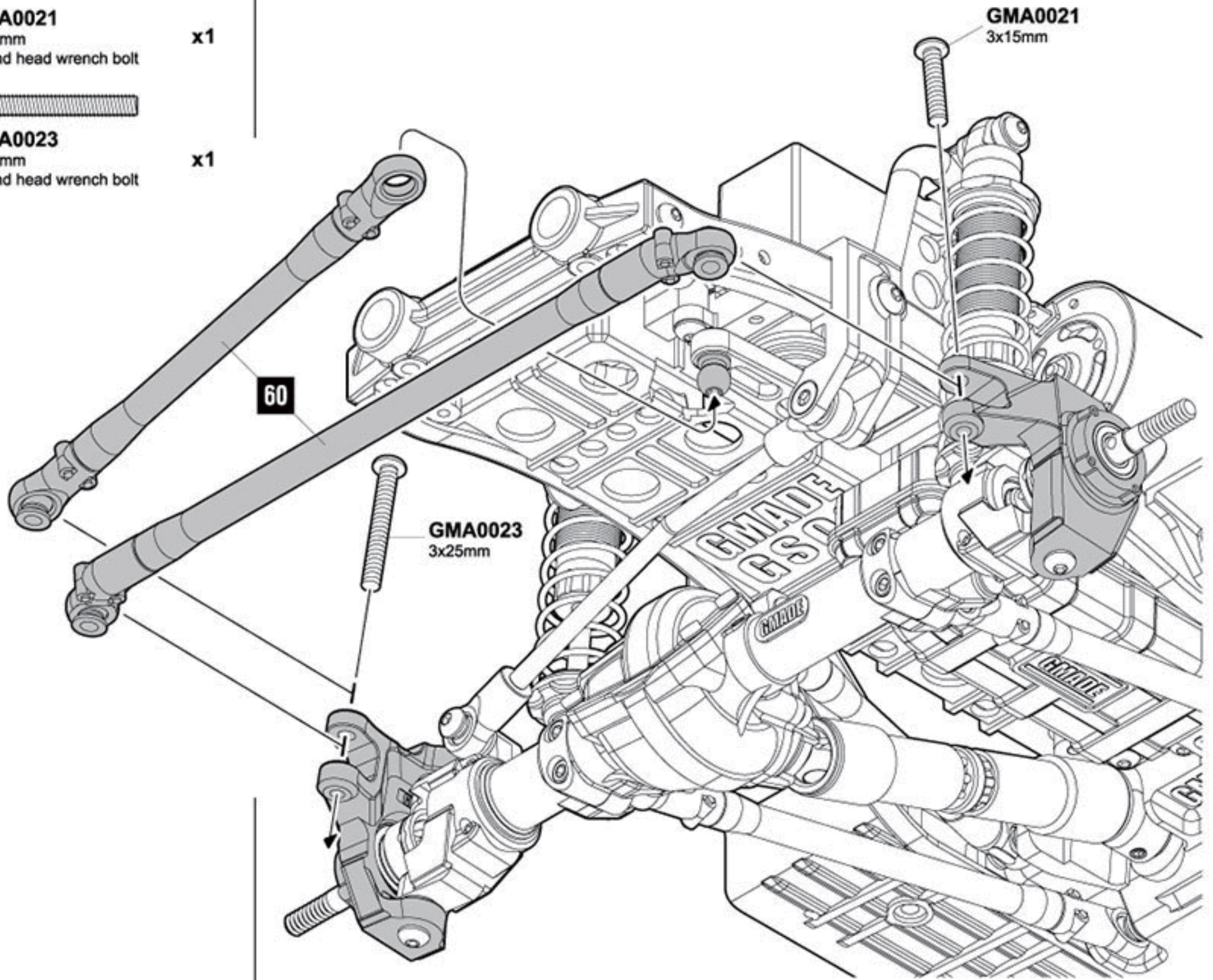

RECEIVER BOX

62

⚠ Receiver is not included.

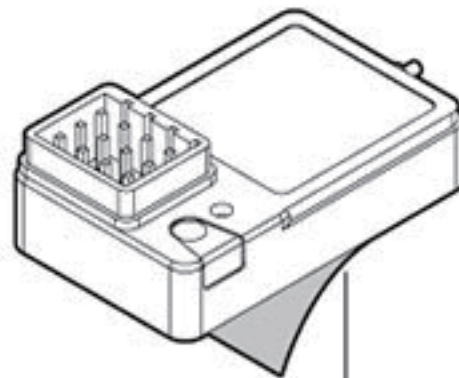

GM60076 **4**

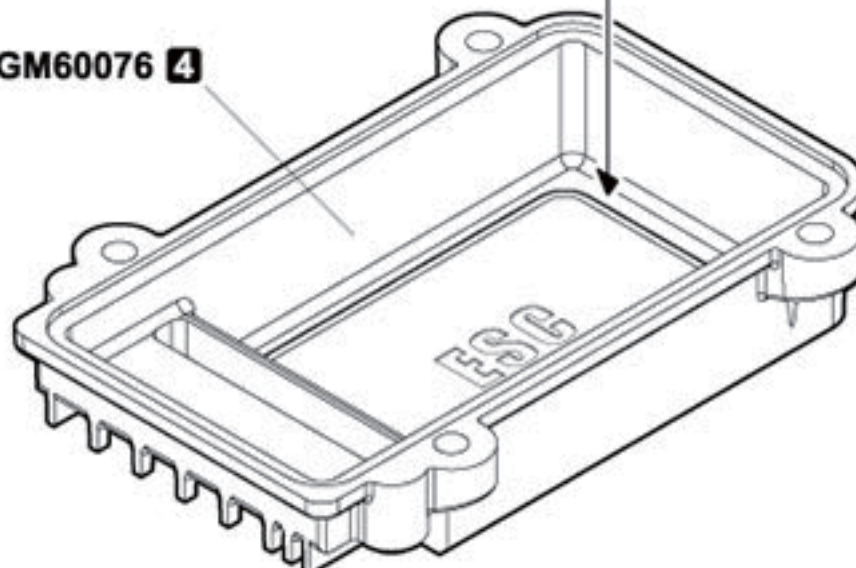

RECEIVER BOX

63

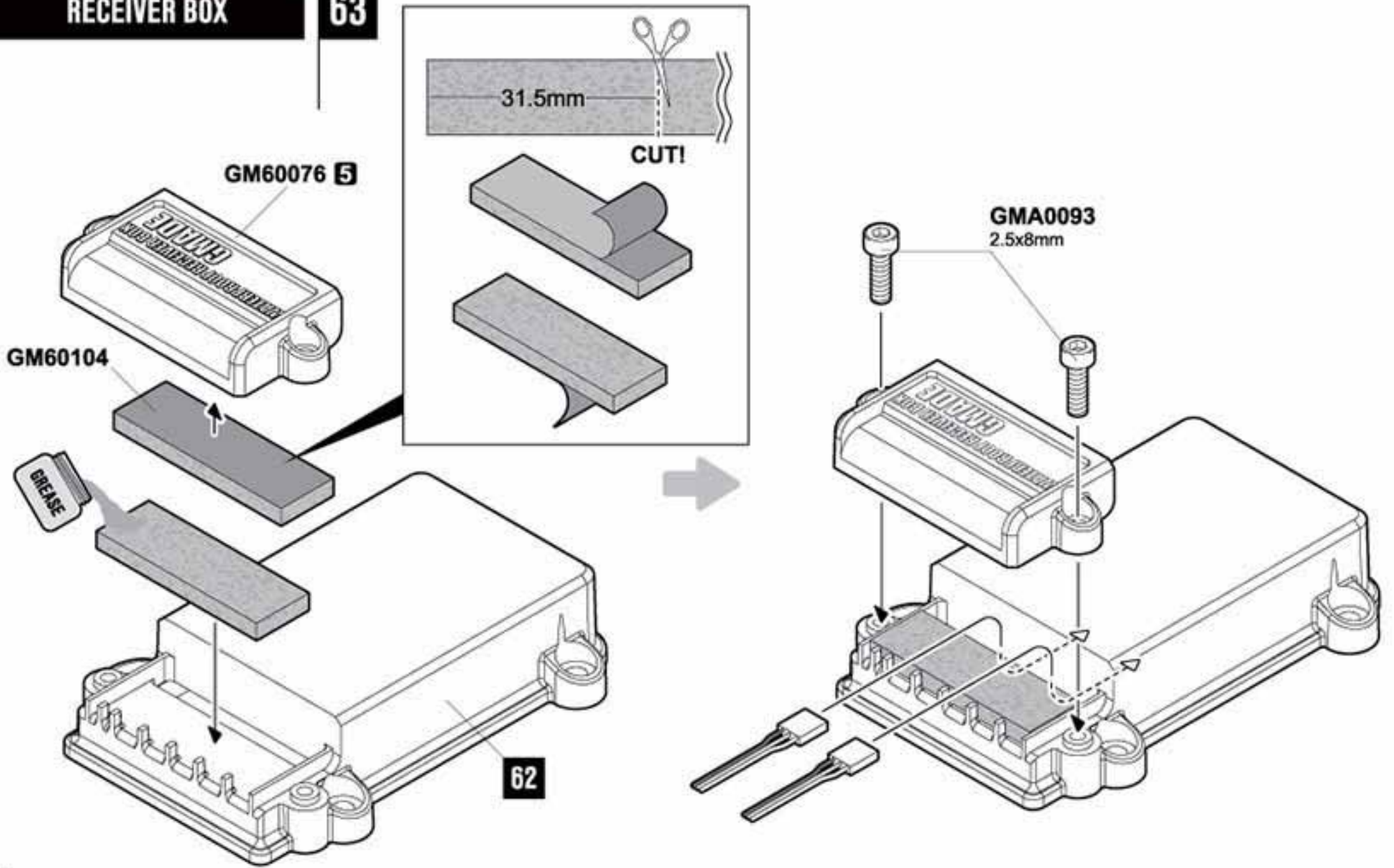

 **GMA0093**
2.5x8mm Wrench bolt

x2

RECEIVER BOX

64

 **GMA0019**
3x10mm Round head wrench bolt

x2

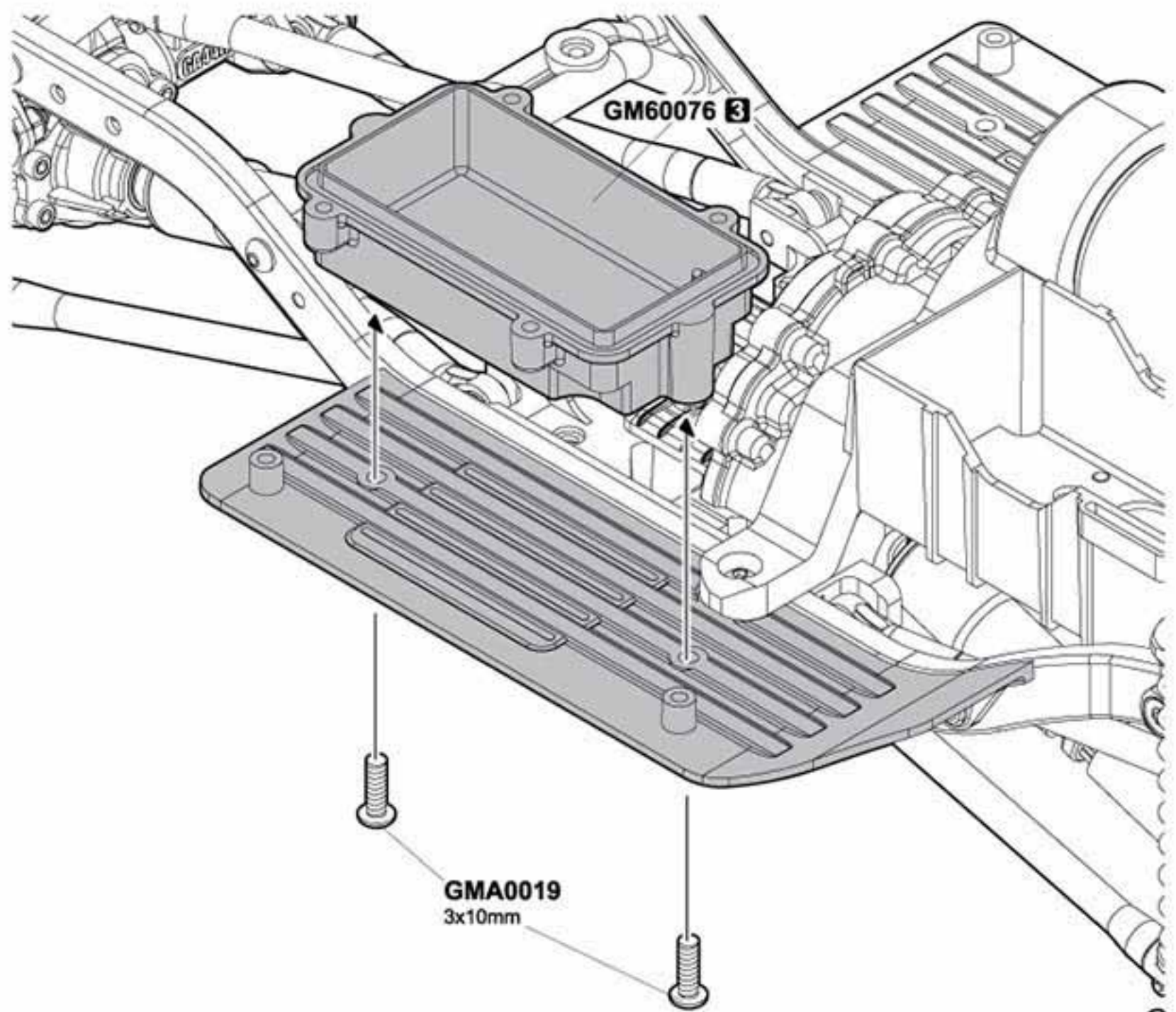

GMA0019
3x10mm

RECEIVER BOX

65



GMA0019
3x10mm
Round head wrench bolt

x4

GMA0019
3x10mm

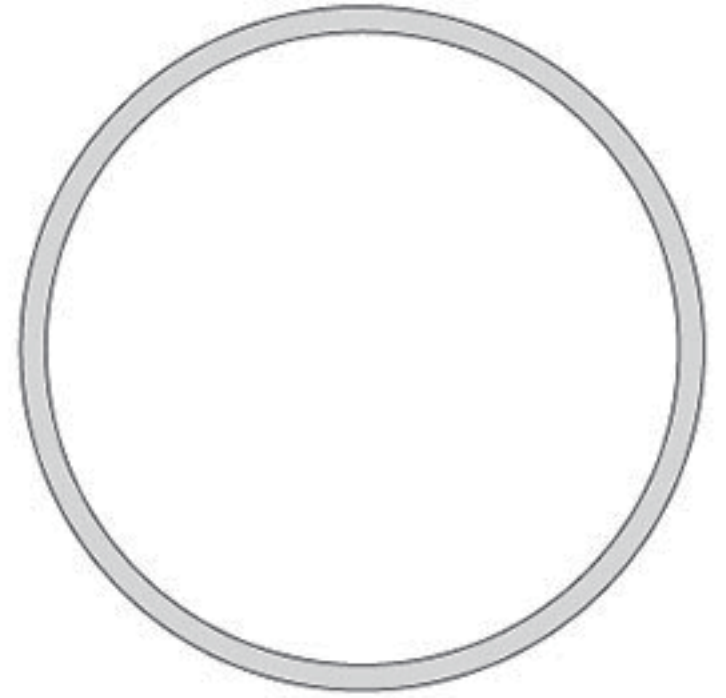

GMA0213 x1
S56 O-ring

63

GMA0213

⚠ ESC is not included.

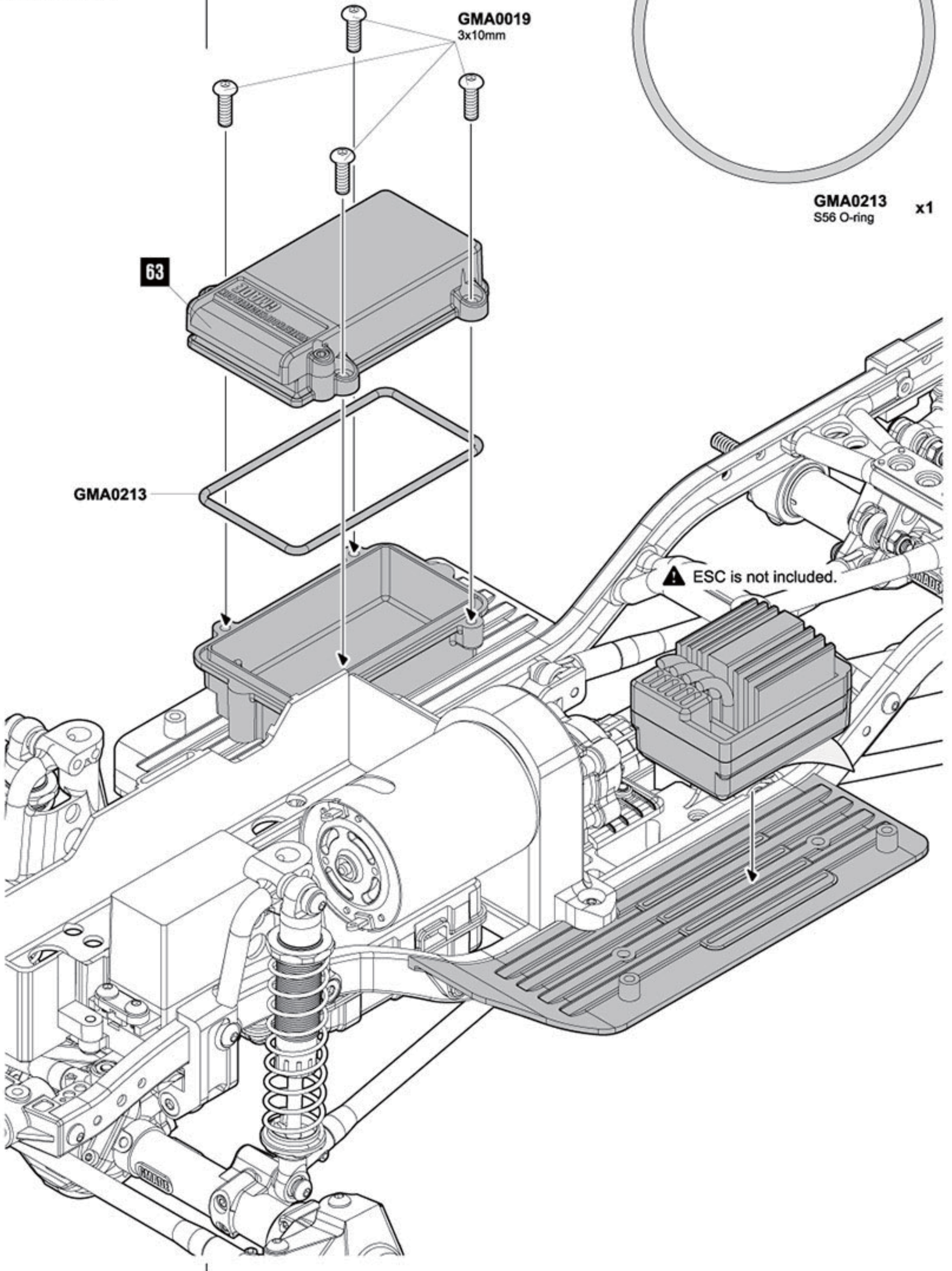

WHEEL HUB

66 ⚠️ TS kit only.

-  **GM51603**
Pin 2x10.3mm x4
-  **GMA0157**
M4 nylon lock nut x4
-  **GMA0126**
3x3mm Socket set screw x4

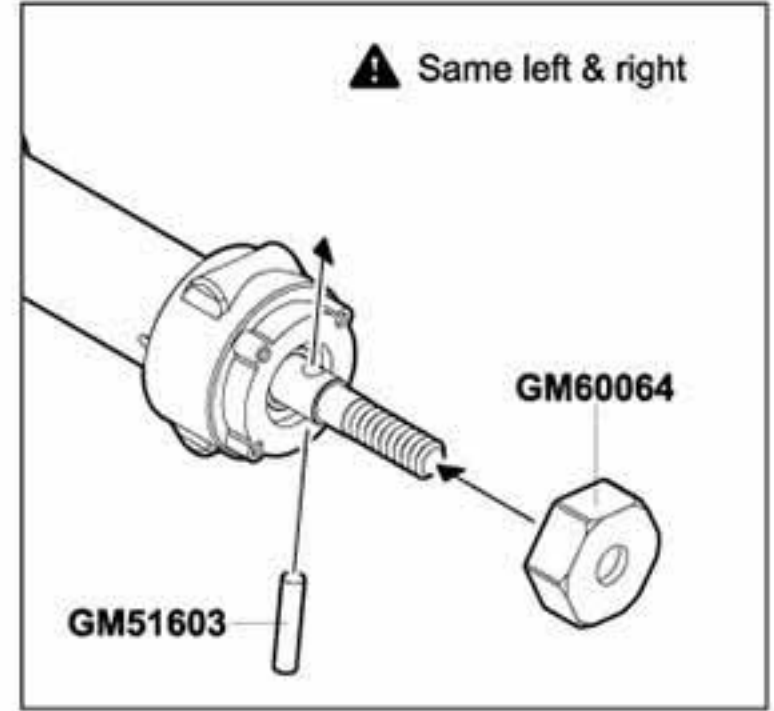
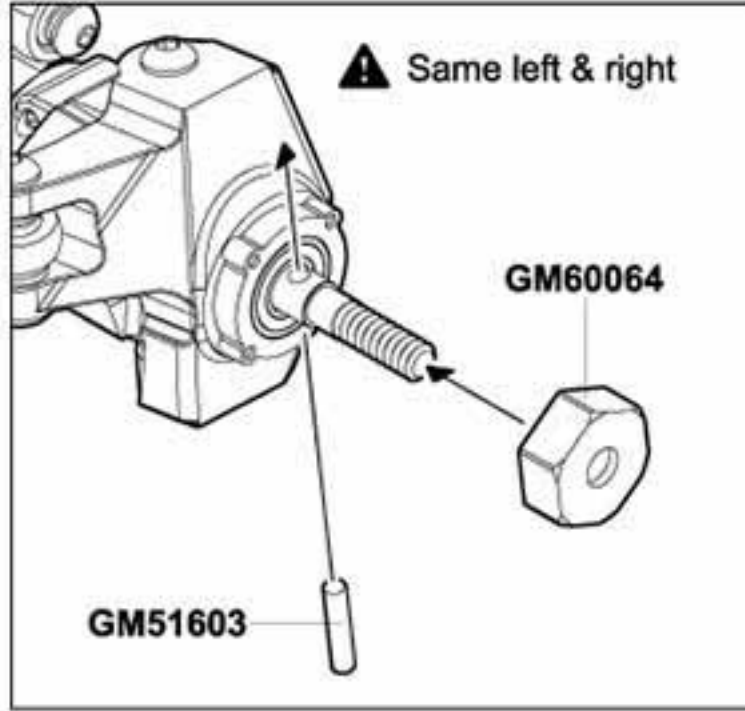

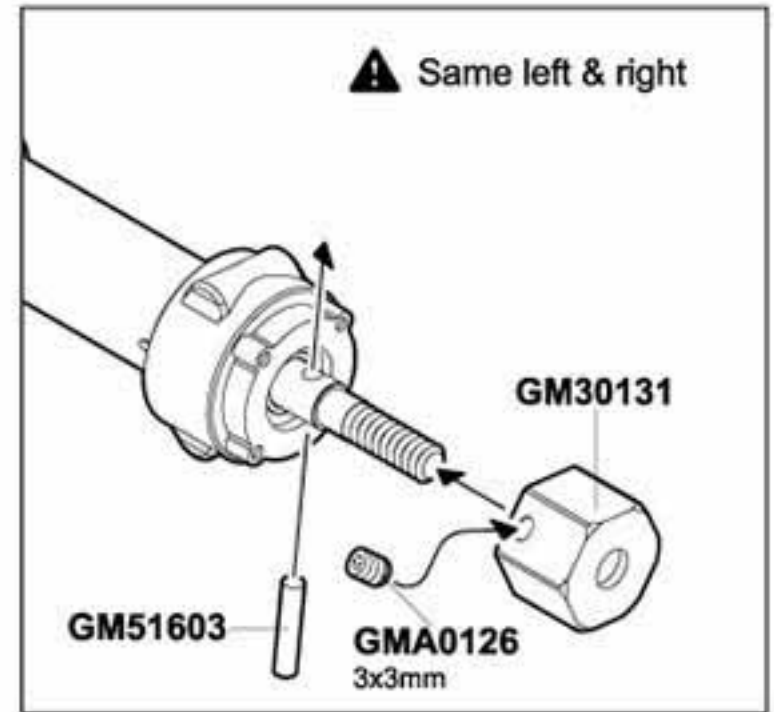
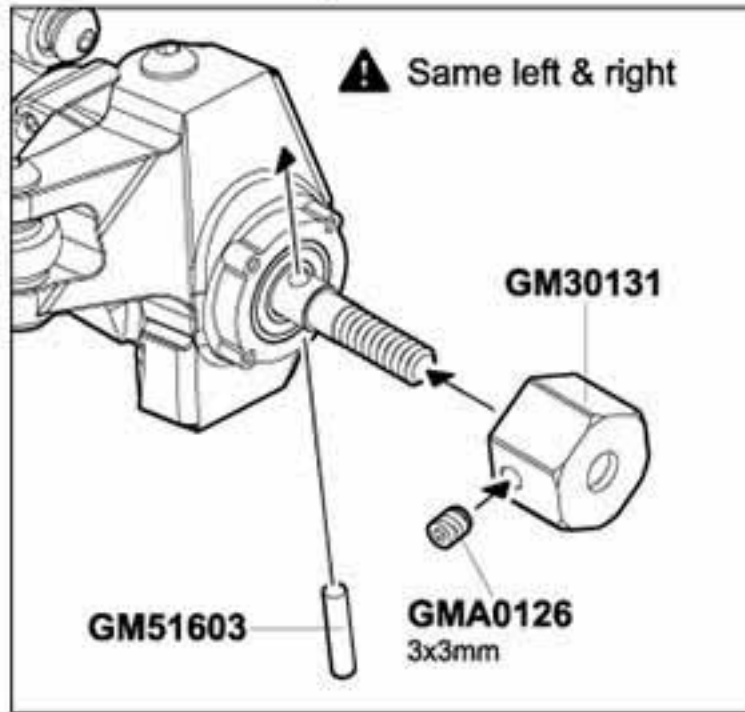

⚠️ TA PRO kit only.



BODY POST

67 ⚠️ Front : Same left & right

⚠️ Rear : Same left & right

-  **GMA0132**
3x12mm Socket set screw x4
-  **GMA0170**
P5 O-ring x4

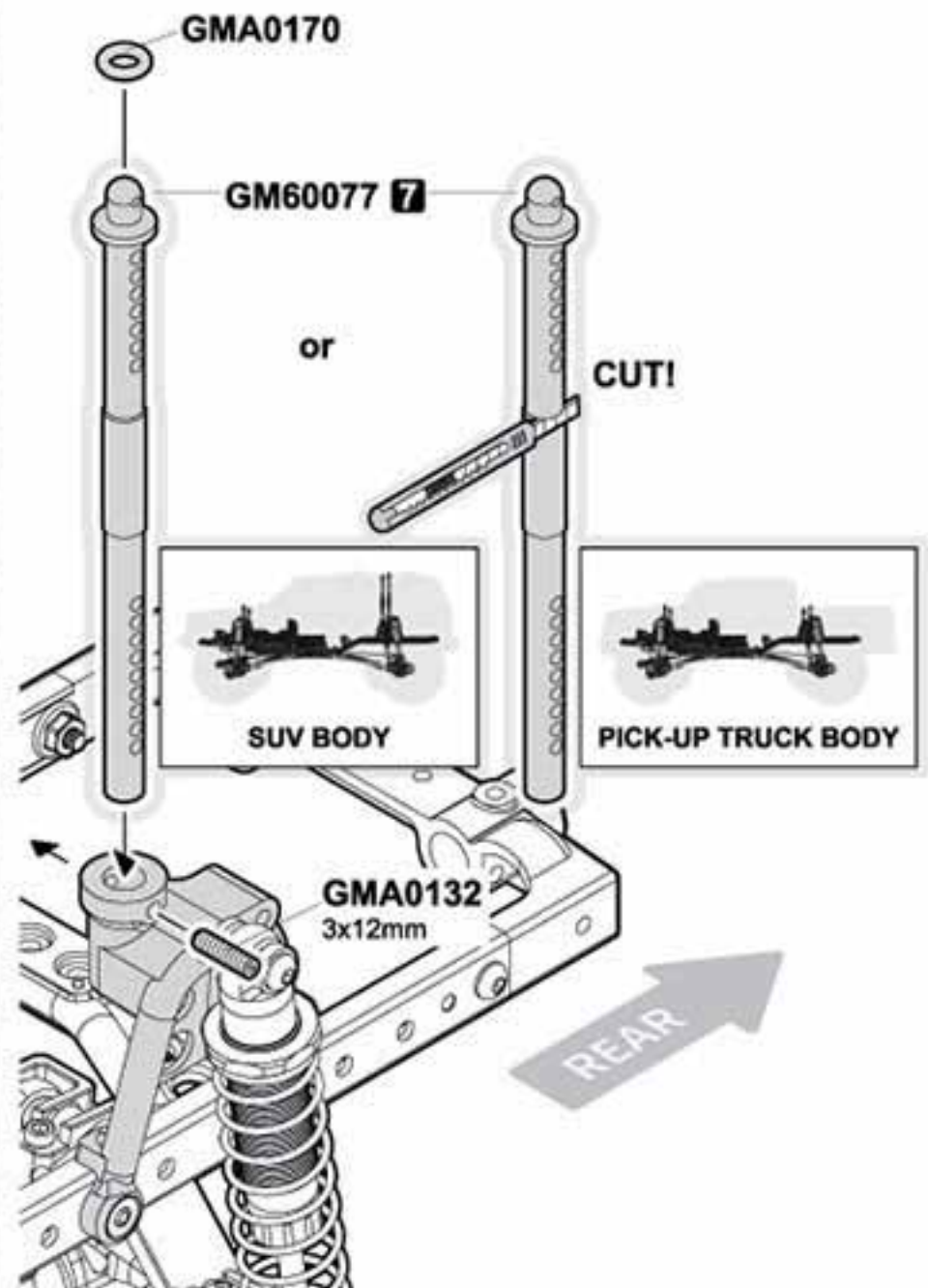
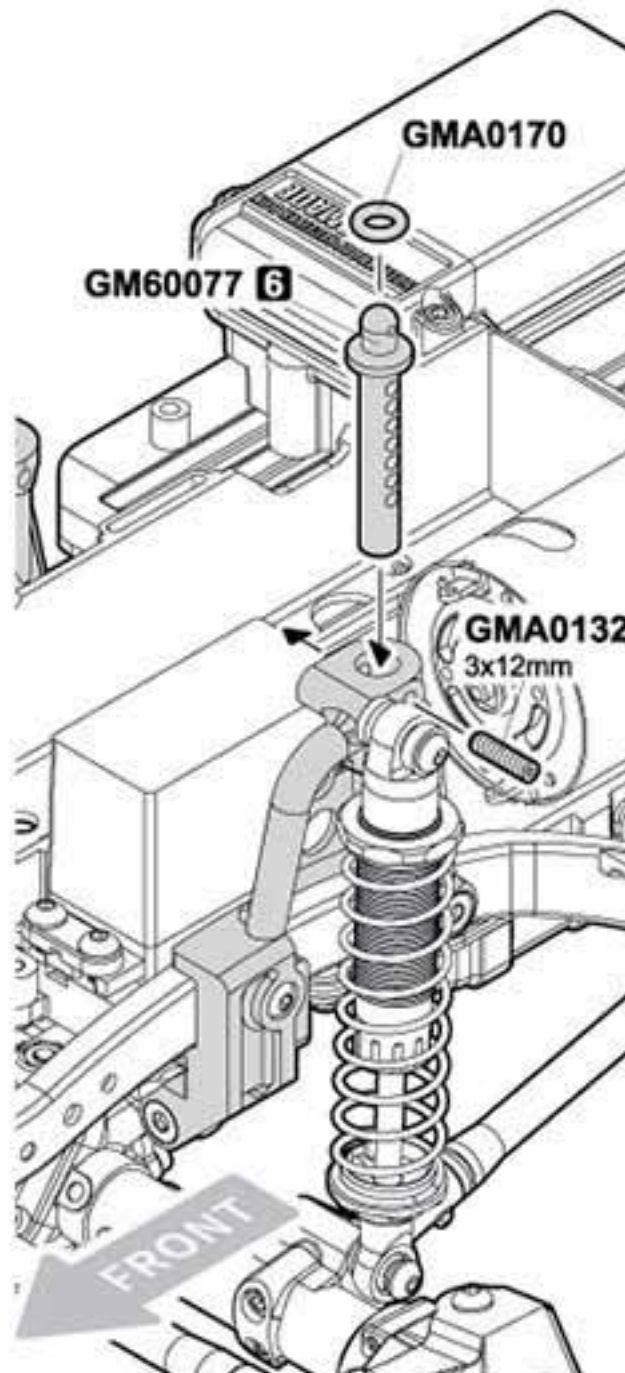

SPARE PARTS LIST

PART#	PRODUCT NAME	PART#	PRODUCT NAME
GM0020075	Shock shaft 3.5x46.4mm (2)	GMA0011	2.5x6mm round head wrench bolt
GM0020078	RSD shock delrin pistons	GMA0012	2.5x8mm round head wrench bolt
GM50116	R6 snap pin (12)	GMA0013	2.5x10mm round head wrench bolt
GM51603	Pin 2x10.3mm (4)	GMA0017	3x6mm round head wrench bolt
GM60022	M4 5.8mm rod end set	GMA0018	3x8mm round head wrench bolt
GM60023	5.8mm ball parts tree	GMA0019	3x10mm round head wrench bolt
GM60033	Pin 1.5x7.2mm (4)	GMA0020	3x12mm round head wrench bolt
GM60061	GA44 front axle housing parts tree	GMA0021	3x15mm round head wrench bolt
GM60062	GA44 rear axle housing parts tree	GMA0022	3x20mm round head wrench bolt
GM60063	GA44 axle parts tree	GMA0023	3x25mm round head wrench bolt
GM60064	GA44 axle hardware set	GMA0024	3x30mm round head wrench bolt
GM60065	Pin 2x11.4mm (4)	GMA0057	3x8mm flat head wrench bolt
GM60067	11T bevel gear	GMA0058	3x10mm flat head wrench bolt
GM60068	33T bevel gear	GMA0060	3x15mm flat head wrench bolt
GM60069	48P 18T gear	GMA0082	2x6mm wrench bolt
GM60070	48P 30T gear	GMA0092	2.5x6mm wrench bolt
GM60071	48P 38T 1st gear (LO)	GMA0093	2.5x8mm wrench bolt
GM60072	32P 13T pinion gear	GMA0094	2.5x10mm wrench bolt
GM60073	TTR transmission housing parts tree	GMA0095	2.5x12mm wrench bolt
GM60074	TTR transmission motor mount parts tree	GMA0109	3x30mm wrench bolt
GM60075	GS02 rear cantilever suspension parts tree	GMA0121	4x30mm wrench bolt
GM60076	GS02 side plate parts tree	GMA0126	3x3mm socket set screw
GM60077	GS02 shock hoop & body post parts tree	GMA0127	3x4mm socket set screw
GM60078	GS02 battery tray & cross member parts tree	GMA0131	3x10mm socket set screw
GM60079	SD shock parts tree	GMA0132	3x12mm socket set screw
GM60080A	32P 45T spur gear (2)	GMA0133	3x15mm socket set screw
GM60081	GS02 frame side rails	GMA0144	4x15mm socket set screw
GM60084	Universal shaft parts tree	GMA0145	4x20mm socket set screw
GM60087	Slipper disk 20x1.5mm (2)	GMA0154	M3 nut
GM60088	Slipper pad (2)	GMA0156	M3 nylon lock nut
GM60089	Upper link M4x6.8x55mm (2)	GMA0157	M4 nylon lock nut
GM60090	Lower link M4x6.8x80mm (2)	GMA0158	3mm washer
GM60091	Upper link M4x6.8x98mm (2)	GMA0159	4mm washer
GM60092	Lower link M4x6.8x100mm (2)	GMA0160	2mm E-ring
GM60093	5.8mm ball stud M3x5mm (5)	GMA0162	4mm E-ring
GM60094	SD 90mm shock body (2)	GMA0163	Ball bearing 5x8x2.5mm
GM60095	SD 67mm shock body (2)	GMA0165	Ball bearing 5x11x4mm
GM60096	Shock shaft 3.5x33.9mm (2)	GMA0167	Ball bearing 10x15x4mm
GM60097	Shock spring 15.2x61mm (2)	GMA0169	P3 O-ring
GM60098	Shock spring 16.2x36mm (2)	GMA0170	P5 O-ring
GM60099	Panhard rod 86mm	GMA0172	3x18mm round head wrench bolt
GM60100	GA44 steering rod set	GMA0205	Ball bearing 8x12x3.5mm
GM60101	Universal joint set	GMA0210	4mm conical spring washer
GM60102	CVA drive coupler (2)	GMA0211	3x18mm flat head wrench bolt
GM60103	3x10mm Screw pin (4)	GMA0212	7x1 O-ring
GM60104	Foam seal (2)	GMA0213	S56 O-ring
GM60109	GA44 CVA kit		
GM60110	CVA pin retaining ring (2)		
GM60111	Input universal joint set		
GM60112	Straight drive shaft 107mm (2)		
GM60113	Transmission shaft 26mm		
GM60114	Slipper shaft 46mm		
GM60115	Transmission output front shaft 25mm		
GM60116	Transmission output rear shaft 63mm		
GM60117	Velcro strap 16x220mm (2)		
GM60119	Universal joint drive coupler (2)		

